



SIGRC62

BUILDING AND FLYING INSTRUCTIONS

INTRODUCTION

The RISER 100 is a standard class sailplane designed for sport and competition glider pilots alike. It's everything a "glider guider" could want in an all around sailplane - ease of building, large size, and great "hang time"! With a 100 inch wingspan and 1000 sq. in. of wing area, the RISER 100 is one of the best floaters around. A modified Eppler-205 airfoil lets the RISER 100 maximize any available lift, while still allowing excellent penetration on windy days. It's outstanding flight performance puts it right at home riding the thermals on a lazy summer afternoon, or going all out in competition against the big guys on contest day.

First-time glider builders will appreciate the straight forward, speedy construction of the RISER 100. The fuselage is built almost entirely of SIG LITE-PLY using our popular "Tee Lock" construction, which practically assures the builder of a straight, strong model. A carefully thought out building sequence takes the builder right from the open box to the flying field. Complete instructions and materials are also included for incorporating optional spoilers in the wing of the RISER 100. Spoilers are essential for making consistent spot landings and for other multitask soaring events. You will also need to decide whether you want to use the standard rubber band wing mounting system shown on the main side and top view fuse plan, or if you want to convert to the optional bolt-on wing attachment as shown on plate 2 of the plans. Complete instructions and materials are furnished in this kit for either version.

The versatile RISER 100 can even make a good R/C trainer! Many model clubs around the country like to train student pilots on a sailplane because of their gentle and slow speed flying characteristics. The slow speed allows the beginner ample time to develop the skills that are necessary for flying radio controlled models. If you have never flown an R/C model before, we strongly recommend that you obtain the assistance of a skilled R/C flier before attempting to fly your RISER 100 by yourself.

Radio Equipment Requirements

The RISER 100 requires only elevator and rudder control, so any radio with two or more channels may be used as long as it is on an aircraft approved frequency.

NOTE: If spoilers are to be used, a radio with at least three channels is required.

Notes Before Beginning Construction

Any references to right or left refers to your right or left as if you were seated in the cockpit. References to inboard means toward the fuselage, while references to outboard means away from the fuselage.

To build good flying models, you need a good straight building board. Crooked models don't fly well! The building board can be a table, a workbench, a reject "door core" from the lumber yard, or whatever - as long as it is perfectly flat and untwisted. Cover the top surface of the building board with a piece of celotex-type wall board or foam board, into which pins can be easily pushed. Don't hesitate to use plenty of pins during assembly to hold drying parts in correct position.

When pinning and gluing parts directly over the full-size plans, cover the plan with wax paper or plastic kitchen wrap to prevent gluing the parts to the plans.

Don't use a ball point pen for making marks on the model during construction. If not sanded off, these ink marks will show through the model's final finish. Use a pencil instead.

Identifying Kit Parts

Leave all die-cut parts in the sheets until needed in construction. Then remove the pieces from the sheets carefully. If difficulty is encountered, do not force the part from the sheet - use a modeling knife to cut it free.

A jig saw works best for cutting out the printed balsa parts. If a jig saw is not available, a sharp modelling knife and a straightedge can be used. Cut just outside the printed lines, leaving all of the line on the part. When fitting the piece into the structure, use a sanding block to bring the edges to an exact fit.

Die-cut plywood parts can be identified using the "KEY TO PLYWOOD PARTS". All of the other parts can be identified by the "COMPLETE KIT PARTS LIST". Sort the different sizes of sticks and sheets into individual piles to avoid confusion during building. Cut all long pieces of balsa first, followed by medium lengths, before cutting up any full length strips into short pieces. NOTE: Save any scrap balsa and plywood until the model is completely done. Some of it may be called for during construction of the model.

COMPLETE KIT PARTS LIST							
Die-Cut Balsa Sheets							
4	3/32"x3"x18" W-2 Wing Ribs	2	3/32"x3"x18" W-5, W-6, W-7, W-8 Wing Ribs	1	3/32"x3"x18" W-3, W-4 Wing Ribs		
Silkscreened Balsa							
1	1/4"x3"x9" Stab, Fin and Rudder parts	1	3/8"x3"x4" Wing Joiner Fill-in				
Sheet Balsa							
1	1/16"x3"x36" Wing Center Sheeting	1	3/8"x2-1/2"x15" Top Hatch Sheeting				
Stick Balsa							
1	1/4" triangle x3" Wing Mount Reinforcements	1	1/8"x1/8"x24" Spoiler Sheeting Reinforcement	4	1/16"x1/4"x36" Fuselage Reinforcement and Polyhedral Sheeting	2	1/16"x1/2"x36" Fuselage Reinforcement and Spoiler Sheeting
4	1/4"x5/16"x36" Stabilizer, Fin, and Rudder Frames	2	1/8"x1/4"x36" Stabilizer, Fin and Rudder Crossbracing				
Special Shaped Balsa							
2	1/4"x2"x12" Tapered Stock for Elevators	2	1/4"x1"x12" Trailing Edge Stock for Spoilers	2	5/16"x1-1/4"x24" Outboard Panel Trailing Edge	2	5/16"x1-1/4"x26" Inboard Panel Trailing Edge
20	1/16"x1"x4" Wing Shear Ribs						
Block Balsa							
2	1"x1-1/2"x 8" Wing Tip	1	2"x2-1/4"x3" Nose Block	2	3/8"x1-5/16"x2-7/16" Wing Hold Down Blocks		
Hardwood							
2	1/4"x24" Outboard Panel Leading Edge Dowel	2	1/4"x26" Inboard Panel Leading Edge Dowel	1	1/4"x5" Elevator Joiner Dowel	1	3/16"x8" Wing Hold Down Dowel
1	1/8"x4" Alignment Pin Dowel	4	3/16"x3/8"x24" Outer Panel Spruce Spars	4	3/16"x3/8"x26" Inner Panel Spruce Spars	6	1/8"x3/16"x24" Outer Panel Spruce Turbulators
6	1/8"x3/16"x26" Inner Panel Spruce Turbulators	1	1/4"x1-1/4"x1-7/8" Plywood Wing Bolt Block	2	1/2"x5/8"x1-1/2" Basswood Wing Bolt Blocks		

Die-Cut Poplar Plywood (Lite-Ply)			
1	1/8"x6"x48" Fuselage Sides	1	1/8"x6"x20" Fuselage Top and Formers
1	1/8"x3"x48" Fuselage Bottom	1	1/8"x6"x12" W1A and W1B Wing Ribs
Die-Cut Birch Plywood			
1	3/32"x4"x6" Servo Rails and Polyhedral Braces	1	1/16"x4"x6" Rib Guages and Fuselage Doublers
Hardware			
2	9/32" o.d. Brass Tube Wing Joiners	1	1/4"x8" Music Wire Wing Joiner
2	4-40 Blind Nuts	2	2-56 Nylon R/C Links
1	4-40 Hex Nut	1	#3 Flat Washer
2	.130" o.d. x 19" Nylon Tubing	1	6' pkg. Dracon Line
2	Lead Weights	4	10-32 x 1" Nylon Bolts
2	Medium Nylon Control Horns	4	2-56 x 10" Threaded Rods
4	#2 x 1/2" Sheet Metal Screws	1	4-40 x 8" Threaded Rod
2	48" Nylon Pushrod Tubing Assemblies	1	4-40 x 1" Nylon Bolt
3	3/64" o.d. Spoiler Actuating and Servo Hook Up Wires	7	Easy Hinges
Miscellaneous Parts			
1	.030"x12" ABS Plastic Skid	1	1/8"x1/2"x14" Servo Mounting Tape
1	38"x50" Plan Plate 1	1	25"x38" Plan Plate 2
1	Decal	1	Instruction Book

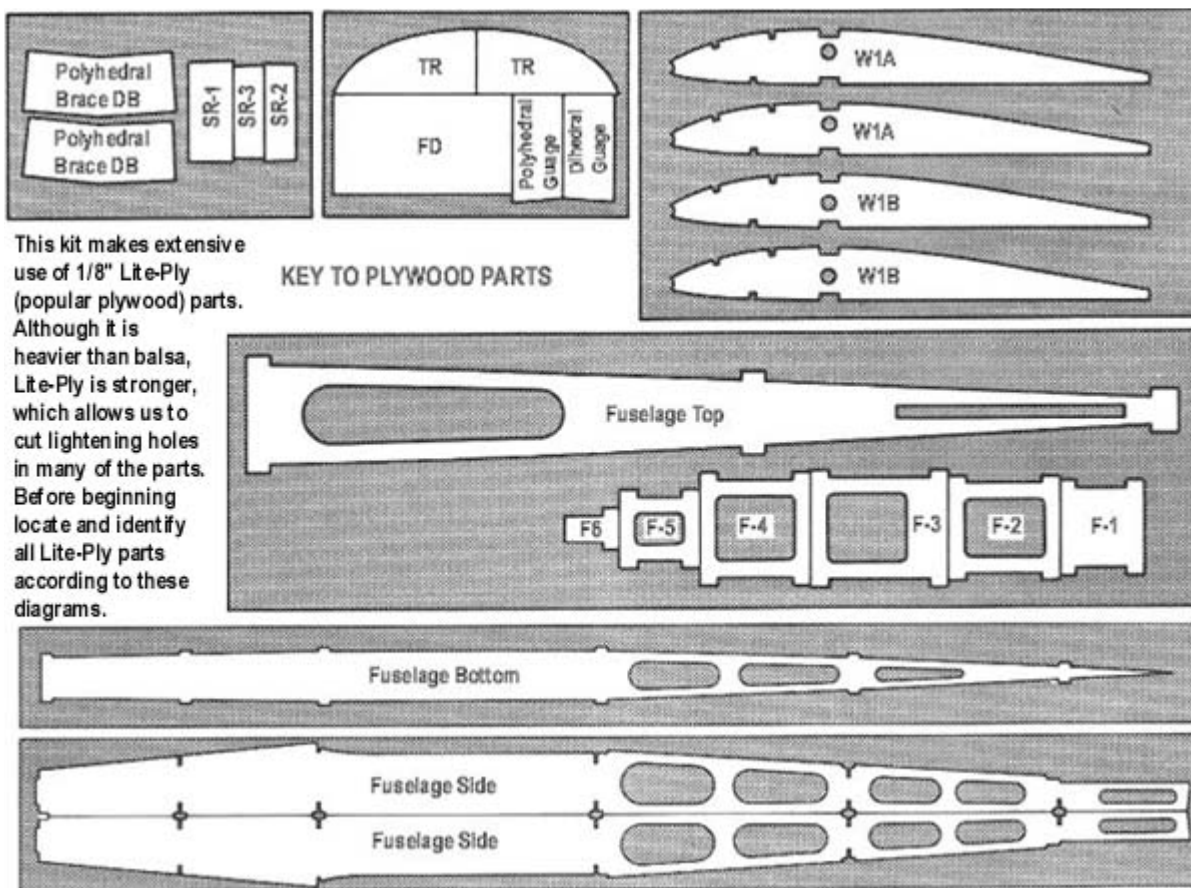

This kit makes extensive use of 1/8" Lite-Ply (popular plywood) parts. Although it is heavier than balsa, Lite-Ply is stronger, which allows us to cut lightening holes in many of the parts. Before beginning locate and identify all Lite-Ply parts according to these diagrams.

You can't get along without a good sanding block

An assortment of different size sanding blocks are indispensable tools for model construction. A good general purpose block can be made by wrapping a 9"x11" sheet of sandpaper around a piece of hardwood or plywood. Use three screws along one edge to hold the overlapped ends of the sandpaper. Put 80-grit paper on the block during general construction. Switch to 220-grit paper for final finish sanding just before covering.

Another handy block can be made by gluing sandpaper onto a 24" or 36" long piece of aluminum channel stock. Most hardware stores carry a rack of aluminum in various sizes and shapes. This long block is very useful for sanding leading and trailing edges accurately.

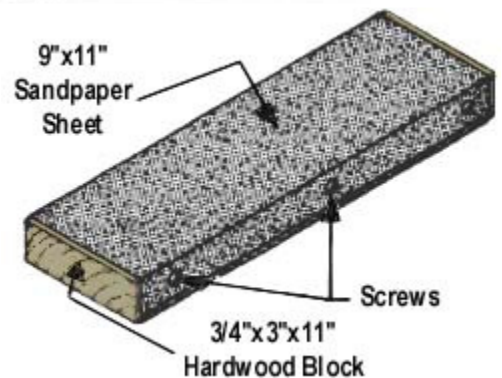

Finally, glue sandpaper onto different sizes of scrap plywood sticks and round hardwood dowels. These are handy for working in tight places and for careful shaping where a big block is too hard to control.

Glues

There are so many different glues available today for model construction that it can be confusing even for the experienced modeler. To simplify matters, most glues can be classified as one of four basic types:

1. Easy-to-use water-based glues such as SIG-BOND (yellow) and SIG SUPER-WELD (white).
2. Super strong (but heavier) two-part epoxy glues such as SIG KWIK-SET (5-minute cure) and SIG EPOXY (3-hour cure).
3. Traditional solvent-based model cements such as SIG-MENT.
4. Fast cyanoacrylate adhesives (abbreviated in these instructions as "C/A") such as SIG CA, Hot Stuff, Jet, etc ...

Each of these types has different characteristics and advantages. Often times, the choice of which type to use is strictly a matter of personal preference based on your prior experience with a previous model. However, because of the vast use of lite-ply and hardwoods in the construction of the RISER 100, we have found that CA glues seem to work the best for the general construction. In fact, the construction sequence of the RISER 100 fuselage is designed with the use of CA glue in mind. Other glues could be used, but CA is recommended as our first choice because of its ability to penetrate an already assembled joint. In other words, the fuse parts can be first assembled dry without glue, the alignment checked and adjusted, and then glue can be applied to the joints. Read through the fuselage construction and you will better understand what we mean. You should also have on hand some epoxy glue, either slow dry or 5-minute, for areas subject to unusual strain or involving metal pieces. Some of the steps in these instructions call out the types of glue to use for that particular assembly. In other areas you can use your own judgement as to which type is best suited to the purpose and your building schedule.

CAUTION: Some people have experienced allergic reactions when exposed to epoxy or cyanoacrylate glues. This is very rare. However, it is extremely important that such glues, and also paints, thinners and solvents, be used with adequate ventilation to carry fumes away.

About Printed Wood Parts

Some years ago we had kits featuring die-cut parts in both thick and thin balsa sizes. If the thick parts were cut from dry wood, the wood often crushed or crinkled on the edges, even when using a brand new die. If the thick parts were cut from wet wood there was an improvement- though many of them still crushed - but the swelled wood parts changed shape after drying, making them inaccurate. So we asked modelers if they would rather have the parts printed on the wood instead. They could be cut out in a few minutes with a saw or modelling knife and thus avoid any "die-crunching". Most voted in favour of this idea.

To answer the question we are sometimes asked - no, we do not print parts on wood to save money. It is actually more expensive to print the parts using a silk screen press than it is to run an equivalent sheet through our automatic feed die cutting machine. If we hand-sawed the parts it would be even more expensive and the labor cost would have to be added to the kit price. We believe that most modelers would rather cut their own out and save the cost. Since there are not many thick parts in our average kit, it really doesn't consume a lot of the total building time for the builder to do the parts.

FUSELAGE CONSTRUCTION

Carefully remove all die-cut Lite-Ply fuselage sides, top, bottom and formers from their sheets. Remove any rough edges on these parts with a small sanding block with 220 grit sandpaper.

1. Drill two holes with a 3/16" drill bit where indicated in plywood formers F3 and F4 for the outer pushrod tubing. There are two small dimples in these formers to mark the correct spot for the holes.

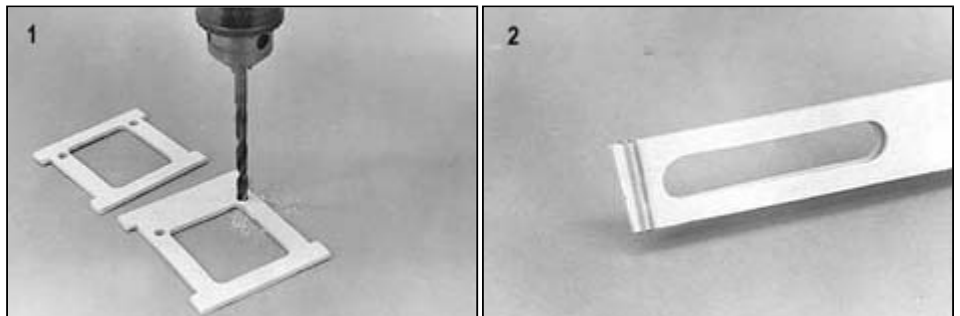

NOTE: If the optional bolt-on wing attachment method is to be used, do not drill these holes in former F4. The pushrods will have to pass through the open middle of that former to avoid interfering with the basswood wing bolt blocks. See Top View of the "Optional Bolt-On Wing" drawings on plan plate 2.

2. Tape or rubber band the two fuselage sides together at the rear.

3. Working from the rear forward, slip all of the fuselage formers into place. Put a rubber band around the fuselage at each former location to hold it tightly together.



4. Slide the die-cut lite-ply fuselage top rearward, under the rubber bands, until it snaps into its proper location between the fuse sides.

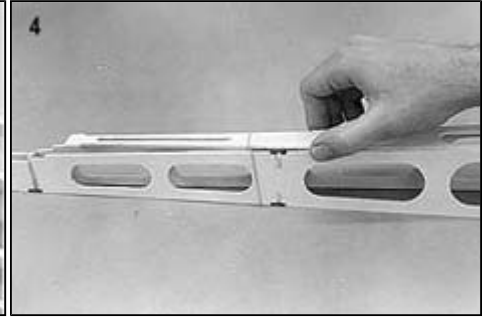

5. Slide the die-cut lite-ply fuselage bottom rearward, under the rubber bands, until it snaps into its proper location between the fuse sides.

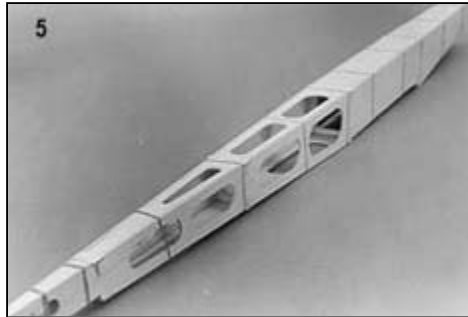

6. Place the fuselage over the top view of the plans to check the alignment. Correct if necessary by twisting gently before proceeding.

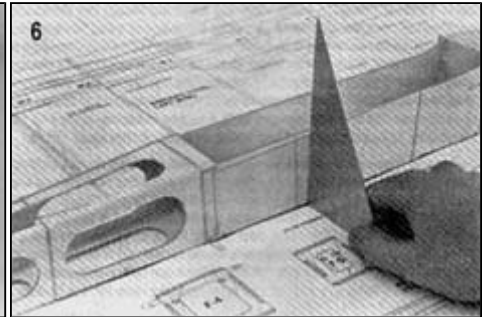

7. Carefully glue all the parts permanently in place, preferably working from the inside of the fuselage, using a medium viscosity CA glue.
NOTE: Be sure to glue both sides of the formers to the top, bottom, and sides of the fuselage. Do not remove the rubber bands until all the glue joints have completely dried.

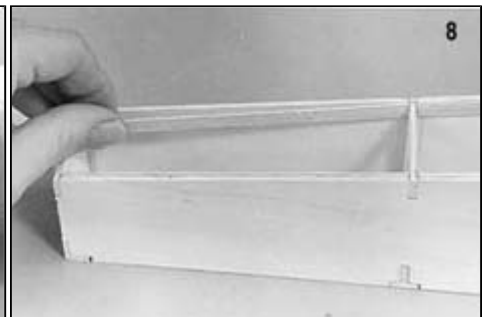

8. Cut and glue in place the 1/16"x1/4" balsa fuselage stiffeners where shown on the plan in the area of the hatch.

9. Cut and glue in place the 1/16"x1/2" balsa wing saddle stiffener as shown on the plans. After the glue has dried, trim the balsa to match the wing saddle.

10. Drill 3/16" dia. holes through the lite-ply fuselage sides for the 3/16" birch dowels required for the standard rubber band style wing mounting. It is best not to glue the dowels in place until after the model is covered.
NOTE: If you are planning to use the optional bolt-on wing attachment, ignore this step.

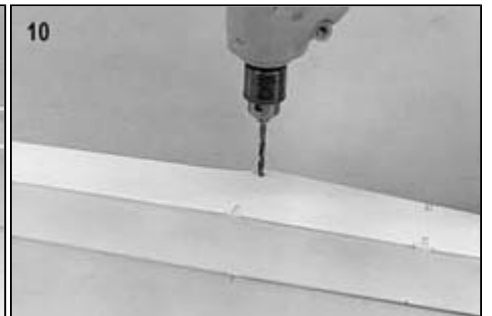
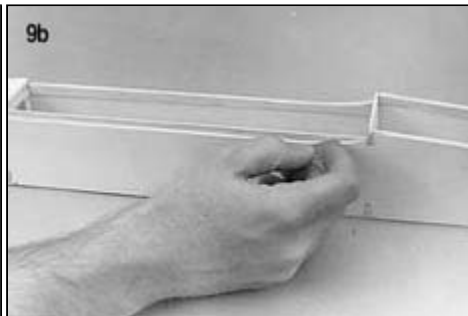
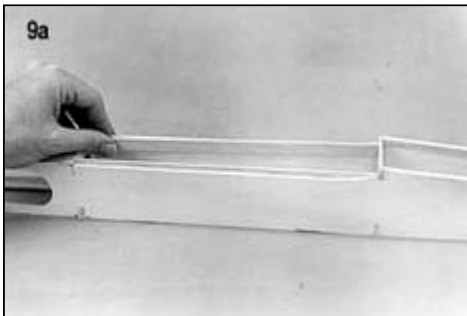

11. a. A 3/8"x2"x15" balsa sheet is provided for making the top hatch. Cut this sheet into a 3" long piece and 12" long piece. Permanently glue the 3" long section in place on top of the fuselage sides, all the way to the front, flush with fuselage former F1.
b. Lightly tack glue the remaining 12" balsa top hatch sheet in place on top of the fuselage sides, right behind the 3" piece. Notice that it extends back past former F3.

12. Glue and pin in place the 2"x2-1/4"x3" balsa nose block. It should be flush with the bottom of the fuselage.
13. Roughly carve the nose block and top hatch sheet to shape as shown on the plans. A razor plane or a #26 X-Acto blade and handle are ideal for this step.

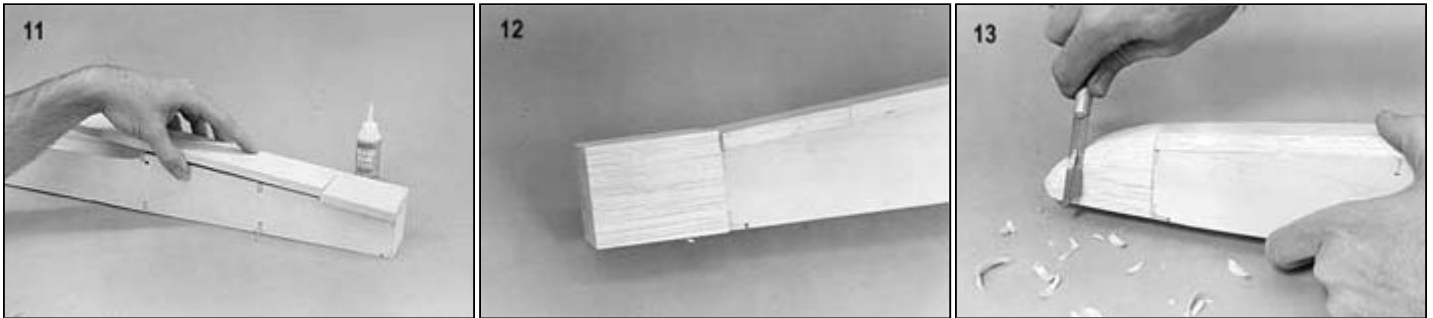

14. Sand the nose block and the top hatch to exact shape with a sanding block and remove the top hatch from the fuselage.
15. Carefully remove the 12" long portion of the top hatch from the fuse sides. Since it was only tack glued it should come off easily. Make a hatch tongue from a scrap piece of 1/16" plywood as shown on the plans. Permanently glue the tongue to the front of the hatch on the bottom side.
16. Cut a piece of scrap 1/8" lite-ply to fit between the fuse sides right in front of former F3. It serves as a hold-down plate for the rear end of the removeable 12" top hatch.
17. Holding the removable top hatch in place, drill a 1/8" hole through the hatch and through the center of the lite-ply hold-down plate. Install a 4-40 blind nut on the bottom side of the hold-down plate and bolt the top hatch in place with a 4-40 x 1" bolt.

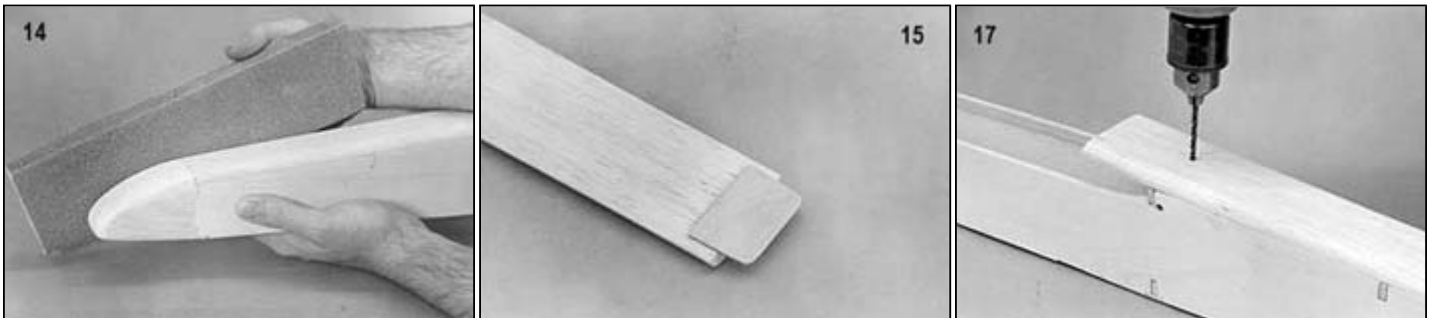

18. That's as far as you can go on the top hatch for now. Once the wing is built, but before covering the model, you must carve out the bottom of the removable top hatch slightly at the rear where it fits down against the wing. The best procedure for doing this is to mount the wing on the fuse, then carefully carve and sand away the bottom of the hatch. Carefully remove just a little material at a time and keep trial fitting the hatch in place as you go.
19. In case you carved too much balsa from the bottom of the hatch and now have a gap, here is a simple method to fix it. Simply cover the wing at the dihedral joint with wax paper and apply a generous amount of Sig Epoxolite putty (or other thick model putty) to the bottom of the hatch and then bolt in place. After the putty has set up, remove the hatch and gently carve and sand off the excess putty.
20. Glue the 1/16" plywood fuselage doubler FD in place inside the bottom of the fuselage.



21. Drill a hole through the bottom of the fuselage and through the fuselage doubler FD for the towhook mounting. Measure the exact location for this hole carefully from the plan, as the towhook position is critical for achieving a good launch of the sailplane. Install a 4-40 blind nut in the hole on the inside of the fuselage.

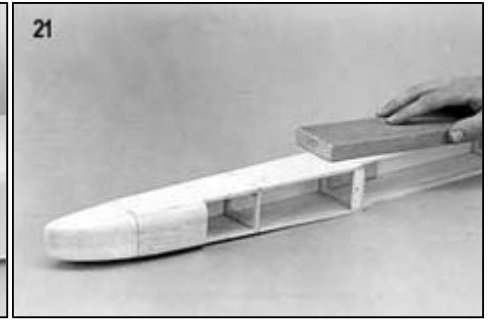
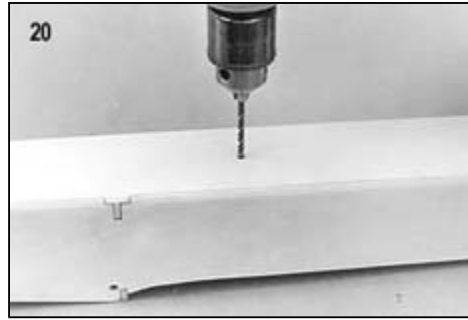

22. The fuselage is now ready for final sanding. Sand off all "Tee-Lock" stubs and round the edges of the fuselage with a sanding block. Start out with 150 grit sandpaper and switch to 220 grit sandpaper for the final sanding.

Servo And Pushrod Installation

23. Drill the elevator and rudder pushrod exit holes in the fuselage sides as shown on the plans. Use a 1/8" drill bit at first for a pilot hole and follow it up with a 3/16" drill bit.

24. Install the 3/16" o.d. outer nylon pushrod tubing for the rudder and elevator pushrods into the fuselage by passing them through the previously drilled holes.

NOTE: Make sure that the outer pushrods extend out past the former F-3 for 3/4".

25. Epoxy the outer pushrod tubing in place at the rear of the fuselage and at the formers F-3 and F-4.

26. Use a single-edge razor blade to trim the outer pushrod tubing flush with the outside of the fuselage sides.

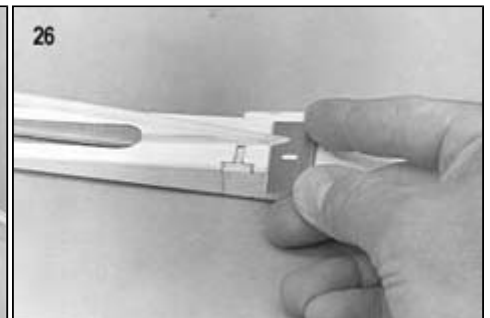
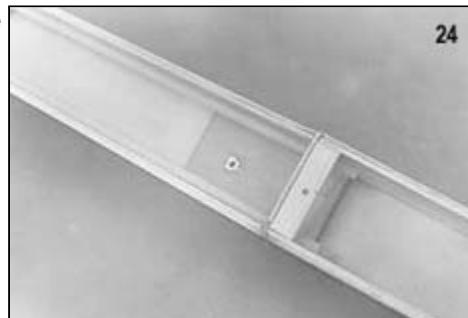
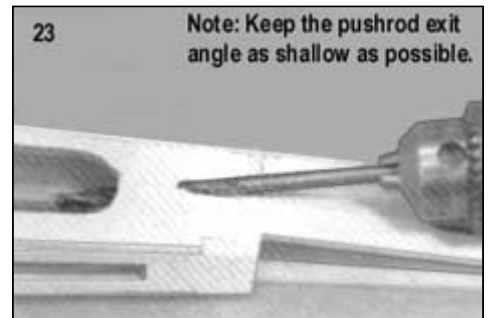

27. Die-cut 3/32" plywood servo rails (SR-1, SR-2, and SR-3) have been provided. Trim the servo rails if necessary to fit your particular servos. Epoxy the rails in place in the fuselage between formers F-2 and F-3. Mount the servos to the rails in the manner recommended by the radio manufacturer.

The rest of the pushrod installation will be done later during "Final Assembly", after the tail surfaces are mounted to the fuselage.

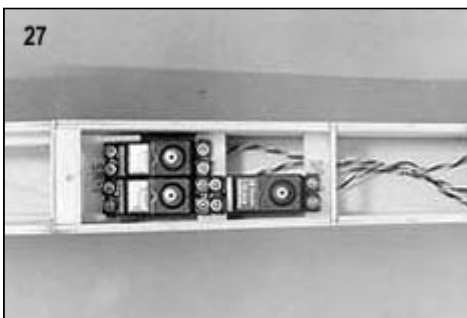

BUILDER'S TIP

Although it's not shown on the plans we recommend that you add scrap pieces of 1/4"x5/16"x1" balsa between the fuselage sides to increase the gluing area for the stabilizer.

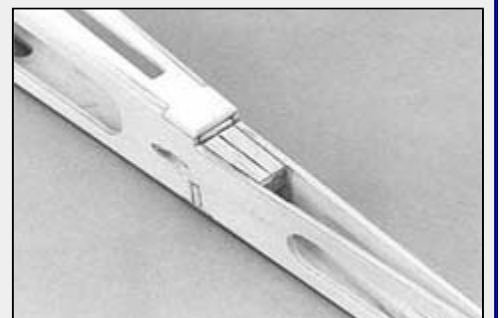

WING CONSTRUCTION

Left Inboard Panel

28. a. Begin by pinning in place the 5/16"x1-1/4"x26" notched balsa trailing edge over the plans.
NOTE: Make sure that you identify the correct trailing edge for each of the four wing panels, the notch spacing is different for each.
- b. Pin in place the 3/16"x3/8"x25" bottom spruce spar, making sure you leave a small amount of excess on each end of the wing panel.
NOTE: Use two W-2 ribs to position the spar the proper distance from the trailing edge.
- c. Cut pieces of 1/16"x3" balsa, from the 36" long pieces provided, for the bottom center section sheeting that goes between the rear of the spruce spar and the trailing edge. Glue and pin in place.
29. Glue and pin all ribs in place except for the two ribs at the ends of the panel (W1A at the dihedral joint and the last W2 rib at the polyhedral joint).
30. Carefully glue the die-cut lite-ply rib W1A in place, using the dihedral guage to position the rib at the proper angle.
- NOTE: The dihedral and polyhedral guages called for in these instructions are provided on the 1/16" die-cut plywood sheet.

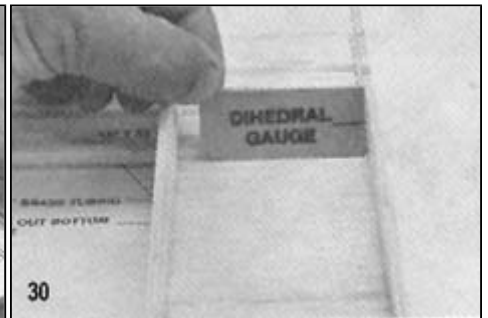
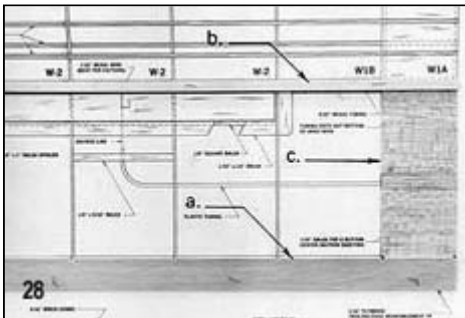

31. Glue and pin in place balsa rib W2 at the polyhedral joint, using the polyhedral guage to position the rib at the proper angle.
32. Glue and pin in place the top 3/16"x3/8"x26" spruce spar, again leaving a small amount of excess on each end of the wing panel. Recheck the end ribs W1A and W-2 with the dihedral and polyhedral guages to insure that the ribs haven't moved.
33. Glue in place the 1/4" dia. x26" birch dowel leading edge and the two top 1/8"x3/16"x26" spruce turbulators. When dry, remove the wing from the board and add the bottom turbulator spar.

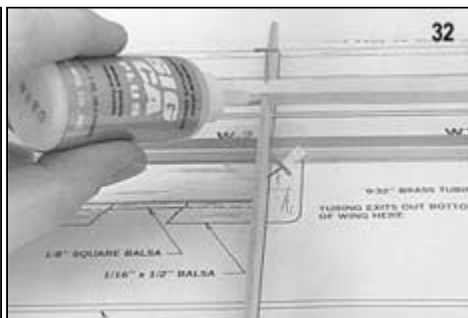
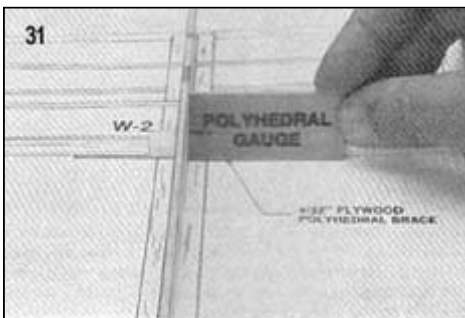

34. Cut off the leading edge, trailing edge, spruce spars and turbulators with a razor saw so they are flush with end ribs.

Set this left wing panel aside for now and repeat steps 28 through 34 to build the right inboard wing panel, so that you will have one left wing panel and one right wing panel.

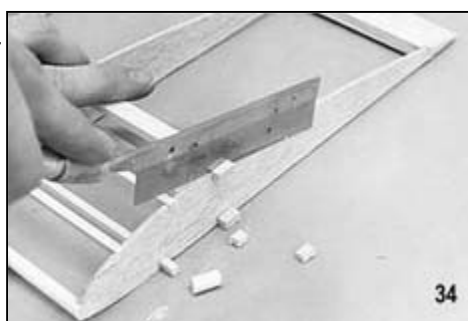

ABOUT TRAILING EDGE RIB NOTCHES

The rib notches may vary slightly in position on the plan because, as noted, the plan paper is subject to shrinking or stretching with humidity changes. Enlarge any notches that aren't deep enough or wide enough with a razor blade and align the rib so that it is parallel to the plan.

Wing Center Section

35. a. Install a piece of 9/32" o.d. x4" brass tubing into the holes in the W1A and W1B ribs. Do the same for both inboard wing panels.
NOTE: Do not glue the brass tubes to the ribs at this time.
Next, slide the 1/4" music wire joiner inside the brass tubes, joining the two inboard wing panels together.
- b. With the center joint firmly down against the workbench, block up each end of the wing panels 1-1/2". Lightly tack glue the 9/32" brass tubing to ribs W1A and W1B and allow the glue to dry. Extreme care must be taken to insure that no glue is allowed to contact the 1/4" music wire!



36. Cut out the balsa fill-in pieces from the 3/8"x3"x4" printed balsa sheet and epoxy glue them in place. Also add a small piece of scrap spruce, from the leftover wing spar material, at the outboard end of both brass tubes to act as a stop for the 1/4" music wire joiner.

37. Trim to fit and glue in place the 1/16"x1"x4" balsa shear webs at the locations shown on the plans.

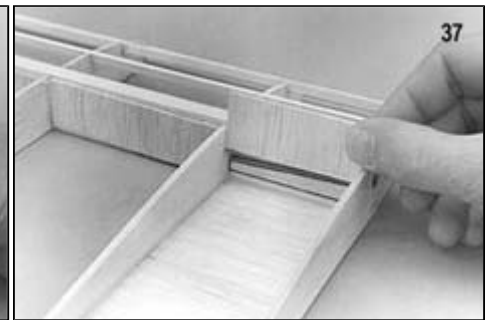
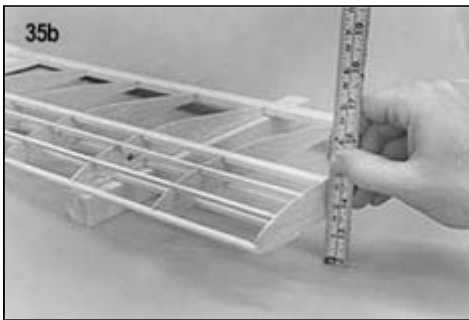

Optional Spoiler Installation

IMPORTANT NOTE: If you have elected not to install the optional spoilers on your Riser 100, skip the following steps 38 through 43 and go directly to step 44 to finish the center section.

38. Two pieces of 1/4"x1"x12" balsa trailing edge stock is provided for making the spoilers. Cut each to length as shown on the plans.
39. Notch the two center W-2 ribs of the spoiler bay to allow the spoiler to fit flush with the top of the wing. Refer to the drawing "Cross-Section at Spoiler" on plate 2 of the plans for proper cut-out location and size.
40. Cut pieces of 1/16"x1/2" balsa sheeting to size and glue in place between the ribs as shown on the plans.
NOTE: Leave a 1/32" gap all the way around the spoiler.
41. Turn the wing panel over and glue pieces of 1/8" sq. balsa against the 1/16"x1/2" sheeting just installed in the previous step. These will reinforce the 1/16" sheeting so that it will not bow or warp when the covering is applied later. Make sure you cut the 1/8" sq. pieces to exact length to fit securely between the wing ribs.
42. Cut a piece 1/4"x 5/16" balsa to fit between the two W-2 ribs that you previously notched for the spoilers. Glue this in place where shown on the plan. This balsa piece will serve as an end support for the plastic tubing called for on the plan. Drill a 1/8" hole through the center of the 1/4" x 5/16" balsa to allow the plastic tubing to pass through it.

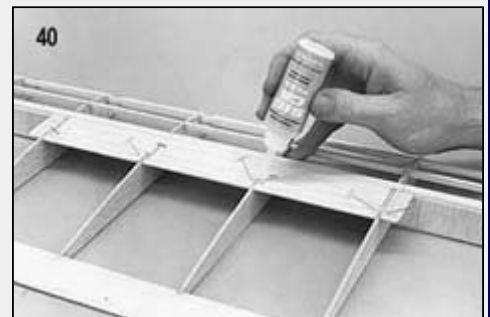

43. Also, drill 1/8" holes through the W1B and W-2 ribs shown on the plan to allow the plastic tubing to pass through them. In addition, cut a small hole in the bottom center sheeting, just behind the spruce spar, where the plastic tube should exit the wing. Carefully slide the plastic tubing in place, using a heat gun where necessary to soften the plastic tubing just enough to allow it to be bent into shape. Glue the tubing securely to the ribs and to the bottom sheeting.

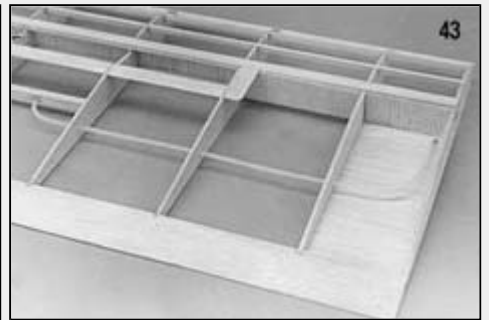
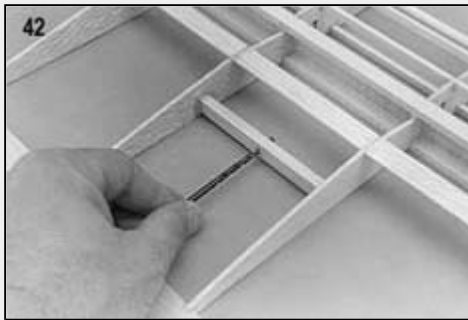

44. Cut and glue in place pieces of 1/16"x3" balsa sheet to fit between the back of the spruce spar and the trailing edge on top of the center section.

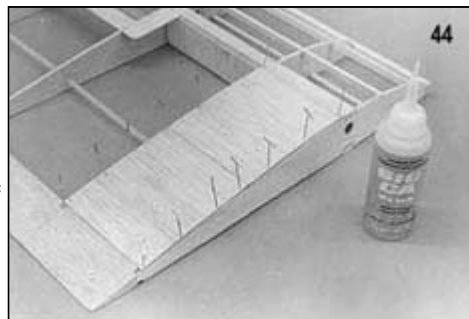

45. Cut and glue in place pieces of 1/16" balsa sheeting to fit between the front of the spruce spar and the turbulators, and between the turbulators and the leading edge on both the top and the bottom of the center section.

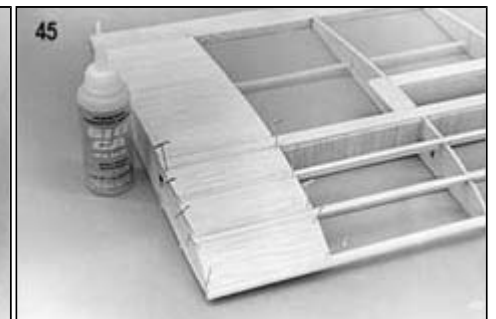

NOTE: If you want to use the "Optional Bolt-On Wing Attachment" method described in the next step, do not glue the foremost top and bottom pieces of 1/16" sheeting that contact the leading edge in place at this time.

IMPORTANT NOTE: If you have elected not to install the optional bolt-on wing attachment method and wish to use the standard rubber band attachment, skip the following steps 46 through 54, and go directly to the section on "Wing Construction: Left Outer Wing Panel".

If you are new to the sport of R/C modeling, it is recommended that you use rubber bands rather than the bolt-on wing attachment. The rubber bands will allow the wing to pop off in a crash and not cause as much damage to the wing or fuselage.

Optional Bolt-On Wing Attachment

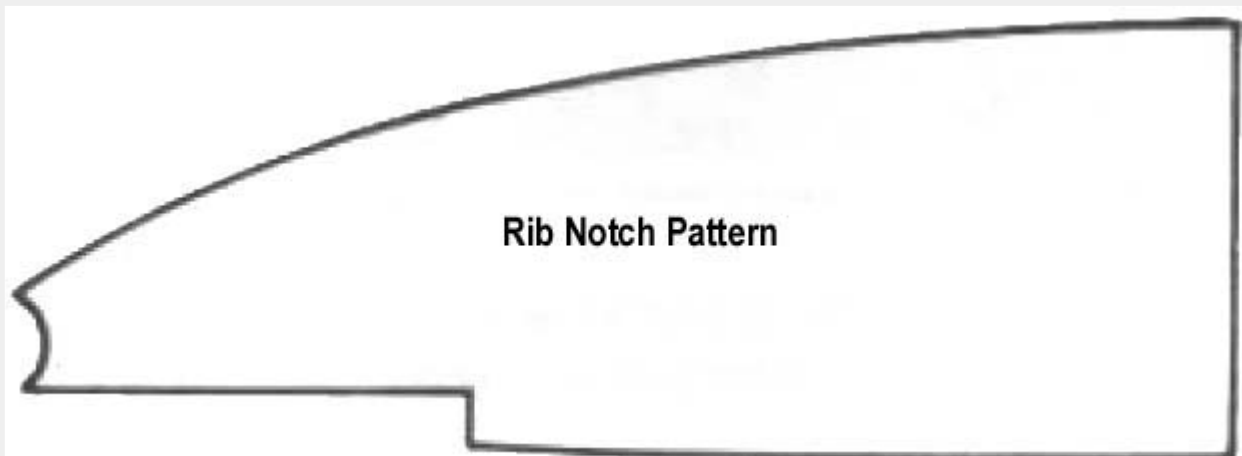

46. Cut out the rib notch pattern. Tape it in place on Rib W1A, and then notch out the rib as per pattern.
47. With a sanding block, bevel one end of each $3/8" \times 1-5/16" \times 2-7/16"$ balsa wing block to match the angle of the W1A rib. Epoxy glue the blocks in place between the ribs W1A and W1B of each wing panel. Use a T-square to make sure the blocks are 90 deg. to the W1A rib and against the back side of the leading edge.
48. Trim and sand the balsa wing blocks down to match the W1B rib with a straight-edged razor blade or a modeling knife. They should be perfectly flush with the bottom of the rib.

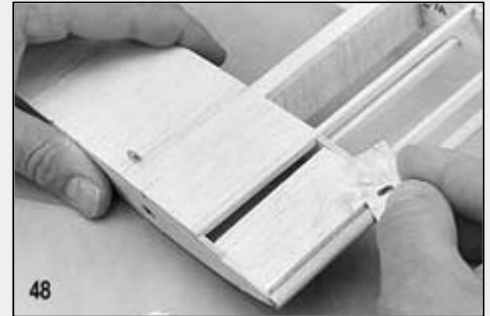
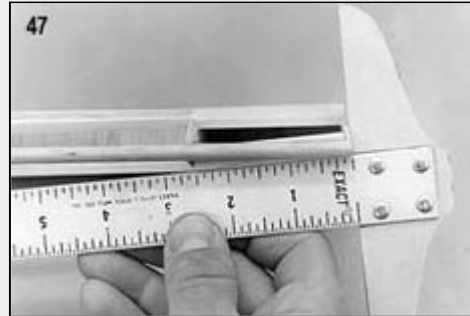
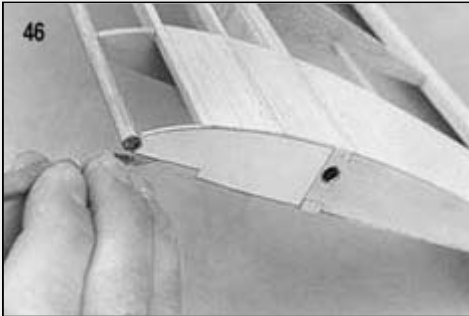

49. Epoxy the $1/2" \times 5/8" \times 1-1/2"$ basswood wing bolt blocks in place as shown in the "Optional Bolt-On Wing" drawings on plan plate 2. With a sanding block, bevel the tops of the basswood blocks to match the wing dihedral. You can also round the front inside corner of the blocks a little if desired.

50. Epoxy the $1/4" \times 1-1/4" \times 1-7/8"$ plywood wing bolt block to the back of former F3 as shown on the plan. Reinforce with a piece of $1/4"$ balsa triangular stock.

51. Place the wing on the completed fuselage and properly align it. Make sure each wing tip is the same distance from the rear end of the fuselage. Tape the wing in place and carefully drill through the wing and plywood blocks at the same time with a $5/32"$ drill. On the two rear holes, remember to keep the drill perpendicular to the top of the wing so the heads of the bolts will seat flush against the wing.

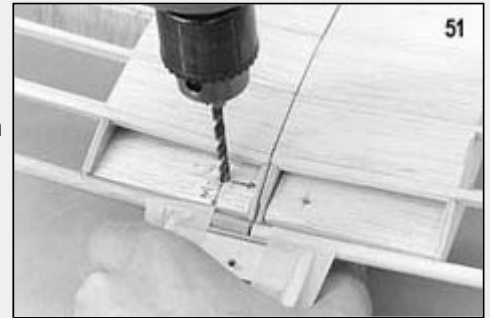

52. Tap the hardwood blocks with a 10-32 tap. Take the wing off and redrill the holes in the wing to $3/16"$ dia. to allow the nylon bolts to pass through.

53. Cut and glue in place pieces of $1/16"$ balsa sheeting to fit between the bottom spruce spar and the bottom turbulator, and between the turbulator and the leading edge. When dry, cut away just enough sheeting to allow the balsa wing block to sit flush on the plywood wing bolt block on the fuselage.

BUILDER'S TIP

Strengthen the threads and the wing bolt holes with a few drops of thin CA glue. When dry, clean the excess glue from the threads with a 10-32 tap.

54. Finally, cut and glue in place a piece of $1/16"$ balsa sheeting to fill in between the leading edge and the front turbulator on the top of the center section. When dry, make a $1/2"$ dia. hole in the sheet for access to the nylon wing bolts.

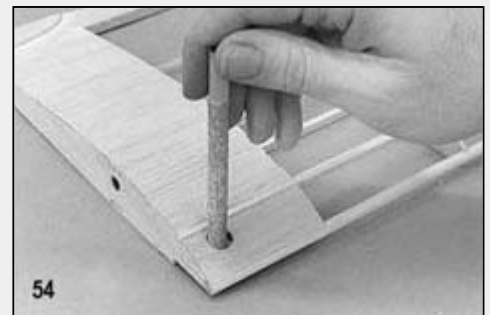
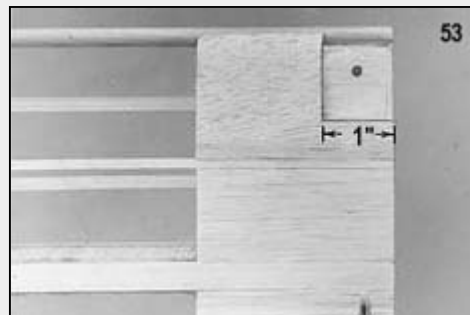
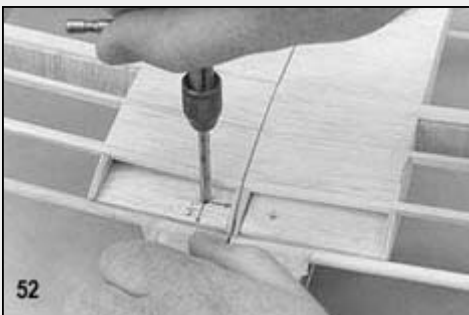

Outer Left Panel

55.
 - a. Pin in place the 5/16"x1-1/4" notched balsa trailing edge over the plans. Make sure that you have the correct trailing edge for each panel.
 - b. Pin in place the 3/16"x3/8"x24" spruce spar, making sure you leave a small amount of excess on each end of the wing panel.
56. Glue and pin ribs W-3, W-4, W-5, W-6, W-7, and W-8 in place on the spar and to the trailing edge. Do not glue in the W-2 rib at the polyhedral joint yet.
57. Using the 1/16" die-cut plywood polyhedral gauge provided, pin the W-2 rib in place at the polyhedral joint and glue it securely.

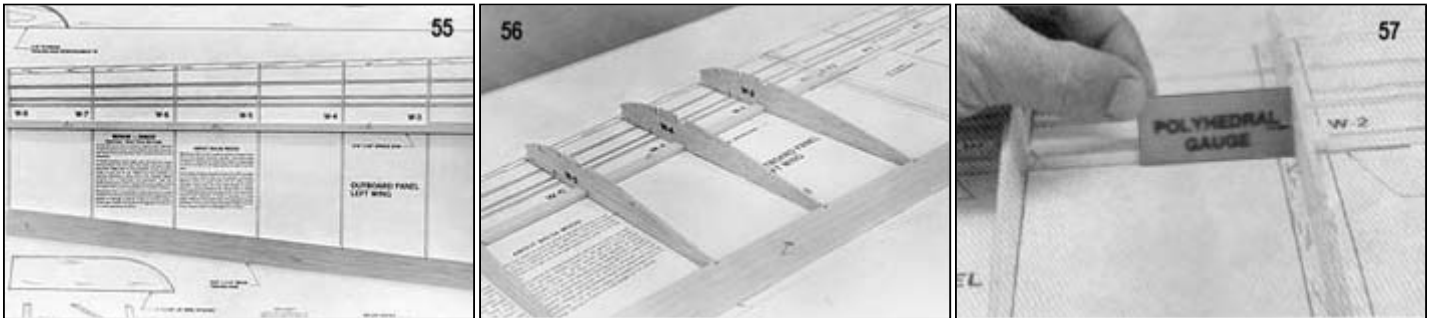

58. Glue and pin in place the top 3/16"x3/8"x24" spruce spar, again leaving a small amount of excess on each end of the wing panel. Recheck rib W-2 with the polyhedral gauge to insure that it hasn't moved.
59. Glue and pin in place the 1/4" birch dowel leading edge and the 1/8"x3/16"x24" turbulators. Remove the wing panel from the building board and add the bottom turbulator.
60. Cut off excess leading edge, spruce spars, and turbulators with a razor saw so that they are flush with the end ribs W-2 and W-8.
61. Cut one of the wing tip patterns from plan plate 1 and trace the wing tip outline onto one of the 1"x1-1/2"x8" balsa wing tip blocks provided.

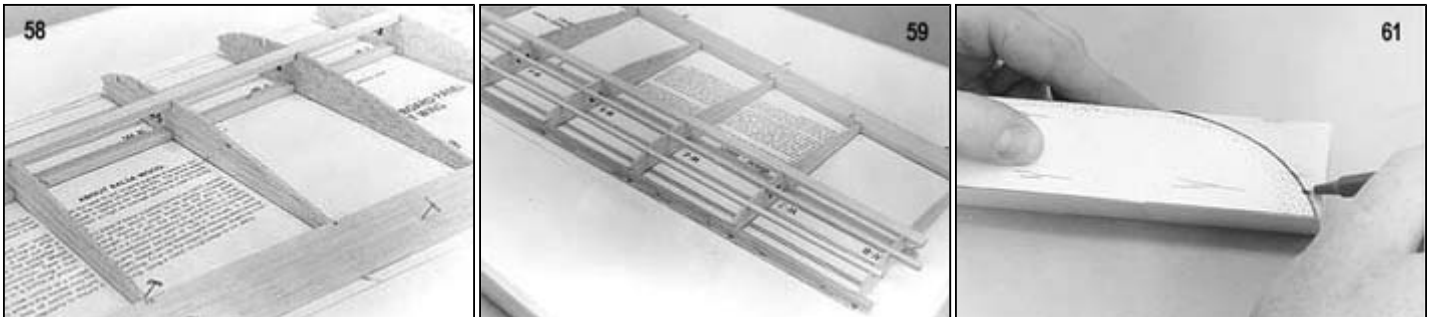

62. Carve the outside radius of the wing tip block first.
63. Place the wing tip block against the tip rib W-8. Trace around it as shown in the picture and then carve down to that line.
64. Glue and pin the wing tip block permanently to the tip of rib W-8.

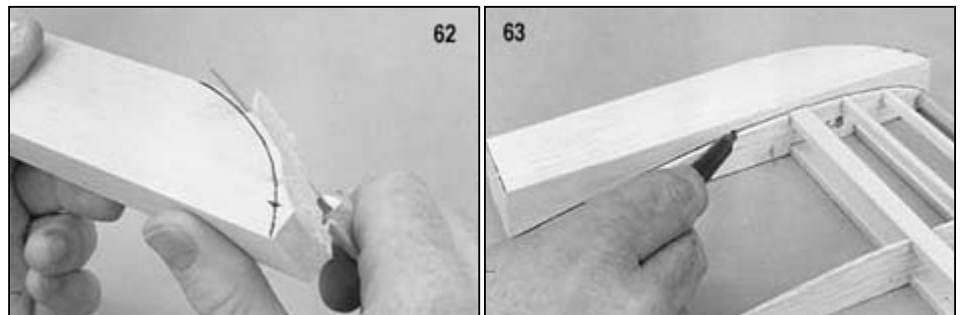

65. Carve and sand the wing tip block to its final shape.

66. Pin down the inboard panel over the plan. Position the outboard panel on the plan against the inboard panel and raise the wing tip 3-3/4" as shown. If the joint between the two panels does not match perfectly, sand one or both of the ribs until it does. Glue the panels together with epoxy glue. Have a wet joint to insure that the glue will fill any gaps in the seam. After the epoxy has set up, take up the wing panels and peel off any excess glue that has squeezed out.



67. Using a razor saw, cut a 3/32" slot in the two W-2 ribs that are joined at the polyhedral joint. Cut the slot right behind the spruce spars to install the die-cut 3/32" plywood polyhedral brace (DB). Epoxy the brace in place.

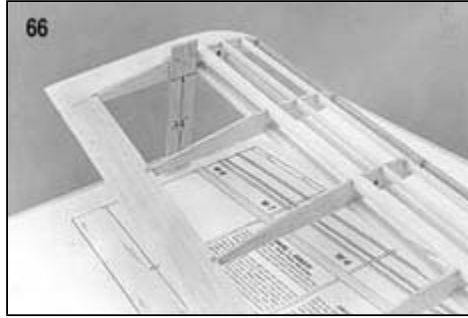

68. Glue and pin in place 1/16"x1/4" balsa strips to the top and bottom of the polyhedral joint as shown on the plans. These strips will serve as a place to attach your covering later. You will probably find that it is difficult to bend and hold the small strips that go between the front turbulators in place while gluing. If so, don't worry about bending them into exact position. They are thick enough that they can be glued straight, sticking out past the ribs, and then trimmed down flush with the ribs as shown here.

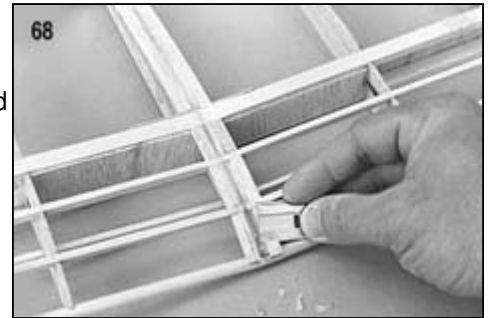

69. Regardless of whether you have elected to use the optional bolt-on wing attachment or the standard rubber band wing mounting, glue the die-cut 1/16" plywood trailing edge reinforcement (TR) piece in place on top of the trailing edge at this time.

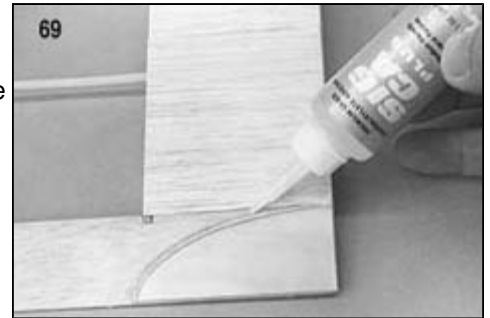

70. Lightly block sand the entire wing half with 220 sandpaper to remove any high spots or glue drops. This wing half is now ready for covering!

Rear Wing Alignment Pin

71. Carefully drill one 1/8" hole in each of the W1A ribs. The exact locations are pre-marked by small dimples in these plywood ribs.
72. Slide the 1/8" dia. x4" hardwood dowel into the hole in the left W1A rib. Push it into the wing panel until it contacts the W1B rib. Next assemble both wing panels to align the dowel pin. Spread the wing panels apart just enough to allow you to glue the dowel pin in place with thin CA glue.

NOTE: Be very careful to glue the dowel pin into the left wing panel only!



73. Disassemble the wing panels and cut off the dowel pin so that only 3/4" sticks out of the left wing panel W1A rib. Round the end of the dowel pin with sandpaper.

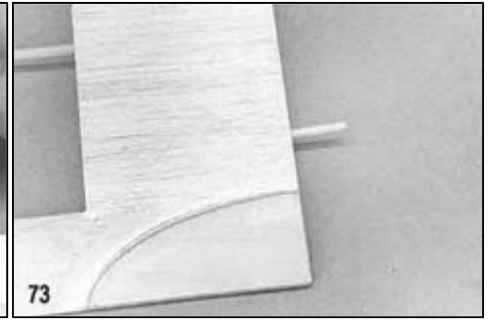

STABILIZER AND ELEVATOR

74. Use a modeling knife or a jig saw to cut all of the tail surface parts (S-1, S-2, S-3, FG, RG-1, and the Dorsal Fin) out of the 1/4" printed balsa sheet. Be sure to cut just outside of the line.

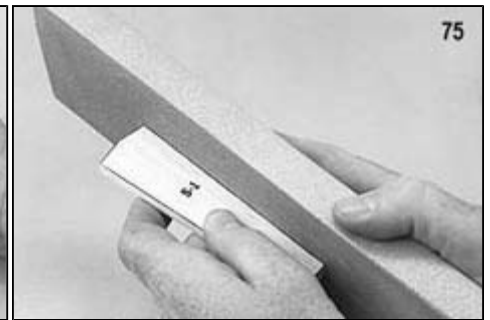
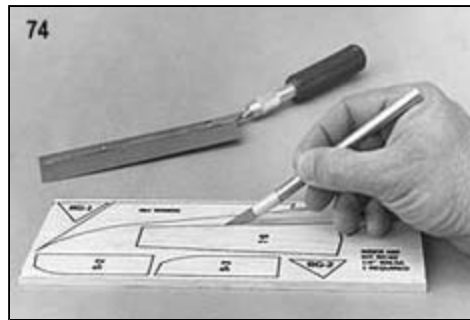

75. Sand stab parts S-1, S-2, and S-3 down to the line with a sanding block.

76. Pin S-1, S-2, and S-3 in place over the stabilizer plan.

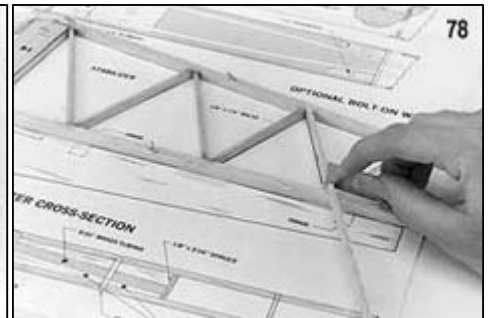
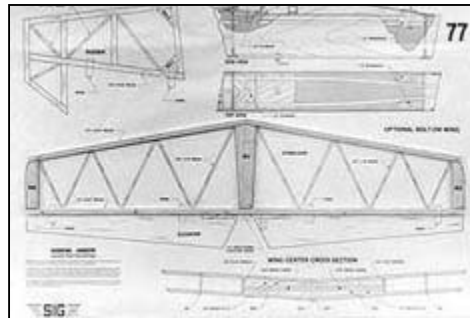

77. Cut to length the 1/4"x5/16" balsa leading and trailing edge pieces. Glue and pin in place over the plans.

78. Cut pieces of 1/8"x1/4" balsa for the stab cross braces.

79. Glue and pin the 1/8"x1/4" balsa cross braces in place over the plans.

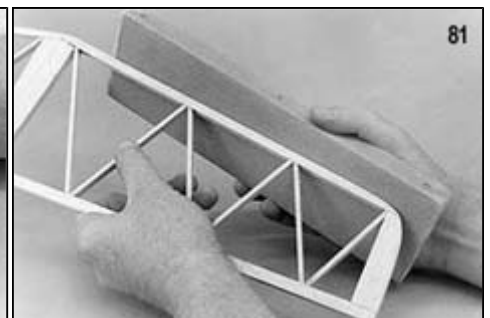
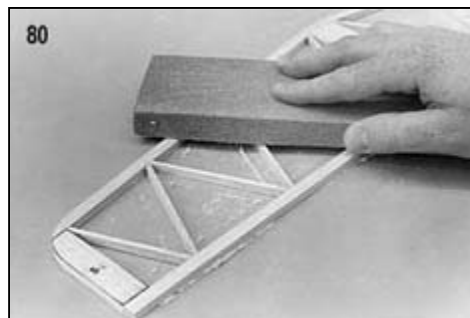

80. Block sand both sides of the stabilizer to smooth out any rough areas. Be sure to sand the printing off the wood.

81. Using a sanding block, sand a curve into the ends of the leading edge sticks to blend into the shape of the stab tips. Then sand the corners of both the leading edges and the tips round. Don't round the corners of the trailing edge of the stab.

82. Two 12" long pieces of 1/4"x2" balsa tapered stock are provided for making elevators. Cut one of the elevator patterns from the plan and trace the outline onto both pieces of tapered stock. Cut the elevators to shape.

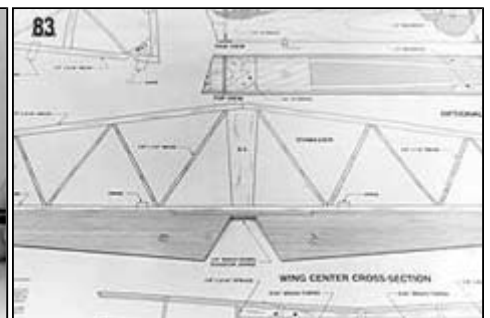
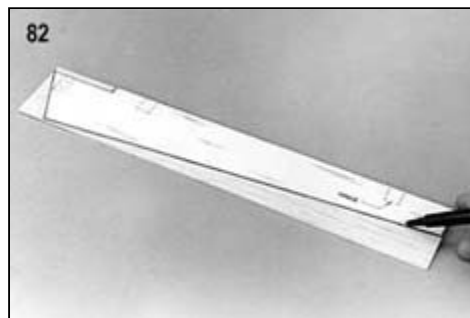

83. Join the elevators together by gluing them to the 1/4" dia.x5" long birch dowel elevator joiner. Pin straight and flat on the building board until dry. Block sand the elevators flat and smooth taking care that the 1/4" leading edge thickness is maintained.

The stabilizer and elevators are now ready to cover.

FIN AND RUDDER

84. Cut the rudder pattern from plan Plate 2 and tape it in place right behind the fin plan on Plate 1.

85. Glue and pin all pieces of 1/4"x5/16" balsa for the fin and rudder in place over the plans.

86. Glue and pin the balsa dorsal fin and gussets FG, RG-1 and RG-2 in place.

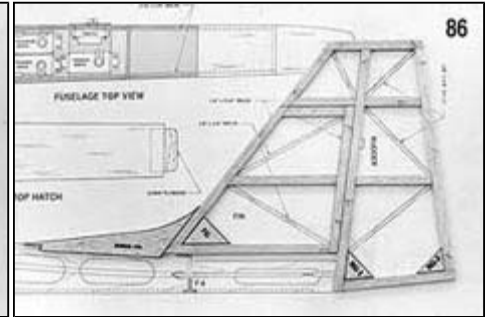
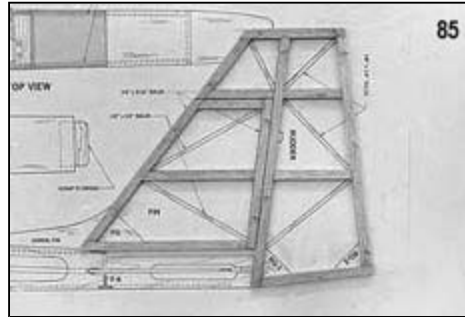

87. Cut pieces of 1/8"x1/4" balsa for the cross bracing and glue in place as shown on the plans.

88. Block sand both sides of the fin and rudder to remove any rough areas. Be sure to sand the print off the wood.

89. Round off all outside edges of the fin and rudder with a sanding block. Be sure to do the leading edge of the rudder so it can hinge properly.

The fin and rudder are now ready to cover.

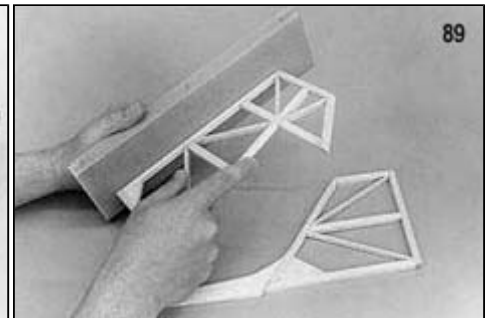
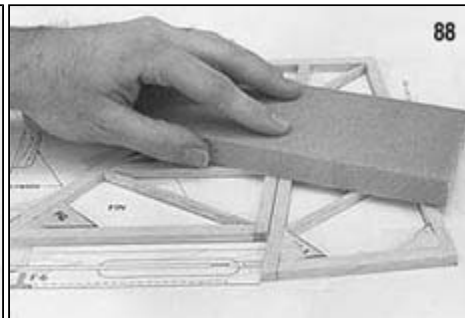
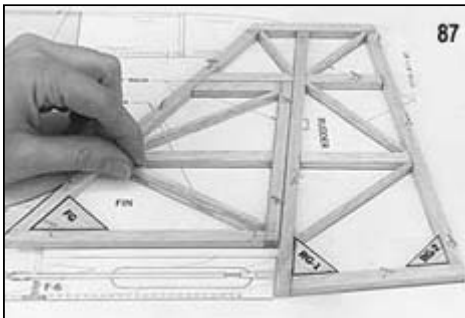

COVERING

All of the RISER 100 prototypes were covered with Sig Supercoat Iron-On Plastic Covering. The covering is ideal for sailplanes because of its light weight and ease of application.

Start by covering the wing from the main spar to the trailing edge with Transparent Blue. Next, cover the wing panel from the spar forward to the leading edge with White. The white should overlap the Blue about 1/2" at the spar! Follow the same procedures to cover the top and bottom of all four wing panels.

The fuselage should be completely covered with White Supercoat, and the Red and Blue stripes are then added with the striping tape. Completely cover the stabilizer, elevators, fin, and rudder with Transparent Blue. Cut the White for the leading edges of the stabilizer and fin from Sig SuperTrim, remove the paper backing, and press the White trim in place. Add Red striping tape to the stab and fin to finish them.

NOTE: If you choose another brand of covering material, be sure to read the manufacturer's directions that come with the material. Follow their instructions closely when applying the material, as different brand coverings can have slightly different handling characteristics and application temperatures. However, the basic techniques for applying iron-on plastic coverings of any brand are similar, and the following hints and photos should be helpful.

90. The structure that is to be covered must be clean, dry, and dust free. Finish sand all the surfaces smooth with 220 or finer abrasive paper. Remember that the covering material cannot hide poor workmanship. Whip the entire surface with a tack rag or a cloth dampened with alcohol to remove excess dust.
91. You should start by covering the bottom of the wing first and then the top of the wing. This leaves the overlapping seam on the bottom where it is less visible. Cut the covering to size, allowing approximately one inch excess around the edges. Remove the plastic backing from the covering and lay the adhesive side against the structure. Lay it down as smooth as possible.
92. Using your hot sealing iron (set a 200 deg. F for Sig Supercoat), tack down the covering material at several places around the outside edges. Once it is smoothly tacked in place, work completely around the edges, sealing the covering entirely to the structure. Don't try to shrink the covering tight at this time.

NOTE: If the surface of the sealing iron becomes contaminated with the colored adhesive that often oozes from under the covering, wipe the iron clean with a dry cloth.

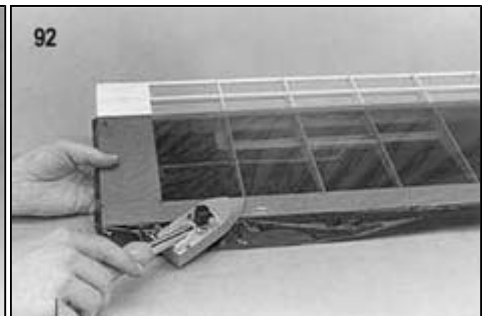
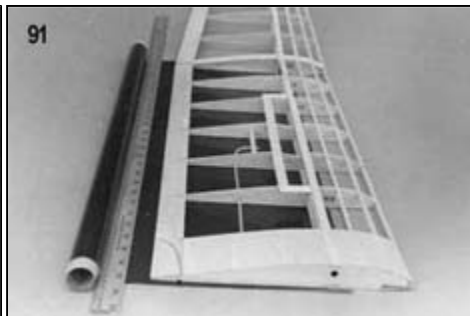
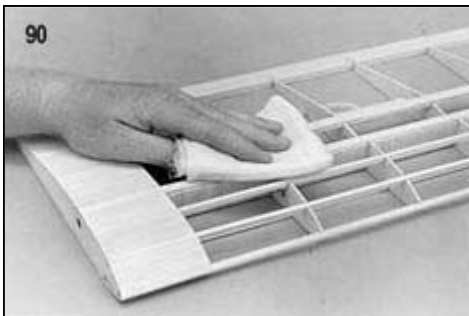

93. Trim off the excess covering with a sharp razor blade or modeling knife.
94. Go over all of the edges of the covering again with the hot sealing iron to make sure they are sealed down securely.
95. Repeat the process from Step 91 to cover the top of the wing. Overlap all covering seams at least 3/8" with the covering material on the other side.

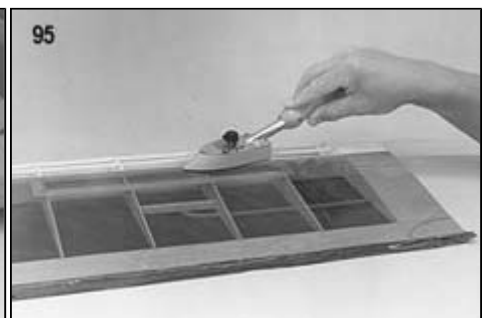
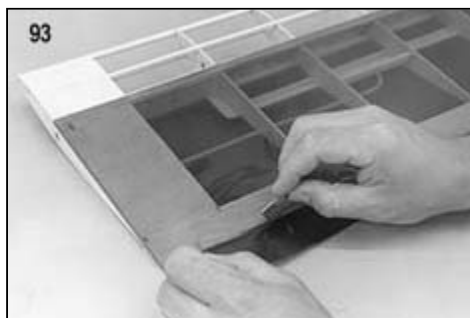

96. To shrink the covering drum tight in the inner areas, we recommend that you use a "heat gun". A household hair dryer will not get hot enough to shrink plastic model covering. You need a special heat gun made specifically for shrinking model coverings. If you do not have a heat gun, you can also use your sealing iron to shrink the coverings tight. Cover the iron with a sock and turn up the heat a little more than it was for sealing the edges to compensate for the sock being on. The sock helps keep the iron from scratching the glossy surface of the covering material.

Move the heat gun or iron back and forth over the surface of the wing, allowing the heat to shrink all of the covering on that side at the same rate. Keep the heat gun moving at all times, about 4" to 6" above the covering. If you stop moving for too long, or hold the gun too close, you might melt a hole in the covering. If you notice that the covering material is "ballooning-up" and not shrinking completely, put a small pin hole in the bottom of each rib bay to allow expanding air to escape.

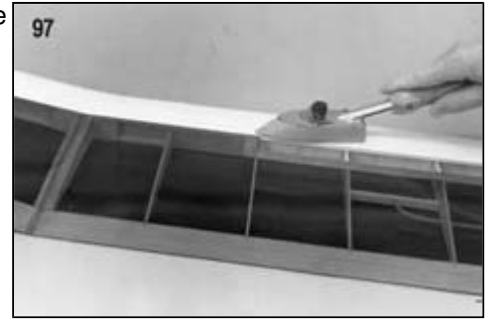

97. Reseal all overlapping seams and edges with a sealing iron. This includes leading and trailing edges, ribs and spars.

98. Cover the bottom of the fuselage first. When cutting the material for the bottom allow enough extra material around the nose, or any other area with compound curves, so you can get a good grip on it with your hand. Start by sealing the covering to the model at the tail. Work slowly forward with the hot iron, sealing the covering smoothly to the bottom of the fuse. When you get to the nose area, work the iron over the covering with one hand while you pull on it with your other hand. As the covering becomes pliable from the heat, you can pull it gently around the curve. Work slowly, allowing the heat to do the work. Do not pull too hard or the covering will tear. When you have it stuck in place, trim off the excess covering material and reseal the edges with the iron.

99. Repeat this procedure for covering both sides of the fuselage. Allow about 1/8"x1/4" overlap onto the top and bottom of the fuse.



100. Cover the fuselage top in the same manner as the bottom and sides. Remember to reseal the edges after trimming.

101. Cover the stabilizer, fin, and rudder using the same techniques as used for covering the wing.

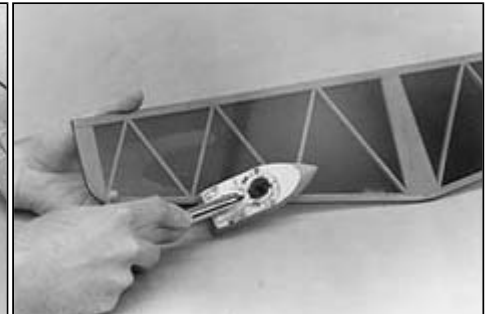
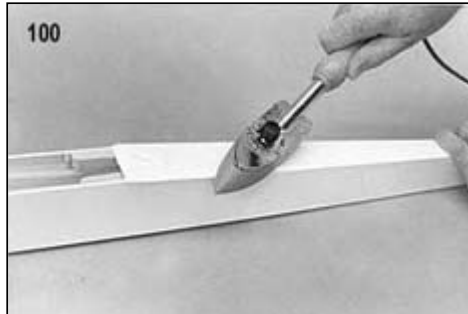

102. Cut away the covering over the pushrod exit holes.

103. Use a sharp razor blade or modeling knife to carefully cut away all covering material in the areas where the tail surfaces will be glued on. There must be wood-to-wood contact in the glue joints. Try not to cut too deep into the wood itself.

104. Cover the bottom side of the elevators first and then the top. When covering solid sheet surfaces like the elevators, better results may be obtained by starting at the center and working toward the outer edges. This allows the air to escape from under the covering as it is applied.

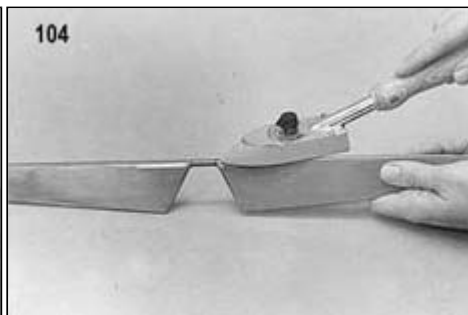
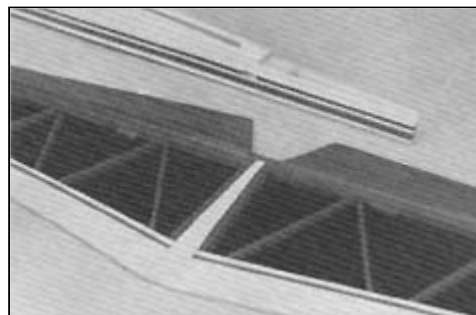

"DKM" Stik-Tite Pressure Sensitive Decals

Cut out the decals with a pair of sharp scissors. Leave about 1/32" to 1/16" of clear edge around the decal. Round the corners as you are cutting. Wet the surface on which the decal will be placed with soapy water (use dishwasher detergent). Place the decal on the model and squeegee the water from underneath with a balsa paddle. Allow to dry. This procedure will prevent air from being trapped underneath as is possible when the decals are applied dry.

INSTALLING EASY HINGES

105. Using a No. 11 X-Acto blade (or similar) cut slots in the control surfaces approximately 1/2" in depth and slightly wider than the hinge at the locations shown on the plans. Continue cutting all of the slots in all the places to be hinged.

106. After all slots have been cut, insert an EASY HINGE halfway into each slot in one of the pieces to be hinged. **DO NOT GLUE THE HINGES YET!** First carefully slide the matching model part onto the other half of the hinges. You'll find it easiest to slide the part onto the hinges at an angle, one hinge at a time, instead of trying to push it straight onto all the hinges at once.

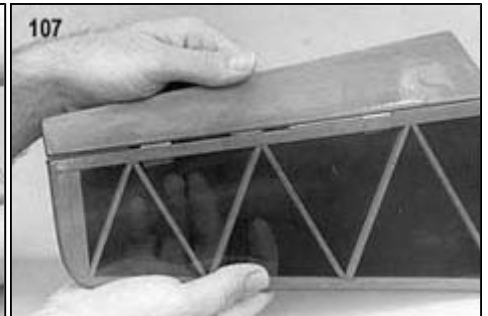
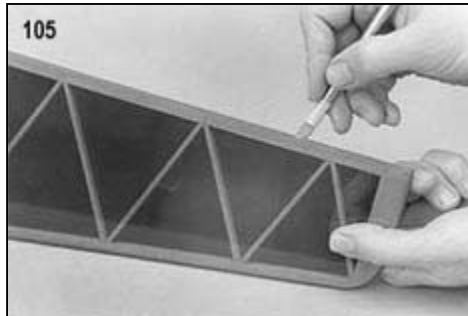

107. At this point the stabilizer and elevator are joined on the EASY HINGES, but the hinges are not glued. Align the stab and elevator, then adjust the gap between them as required. For best control response, the gap should generally be as small as possible but big enough to allow the control surface to move to the maximum deflection that you will require.

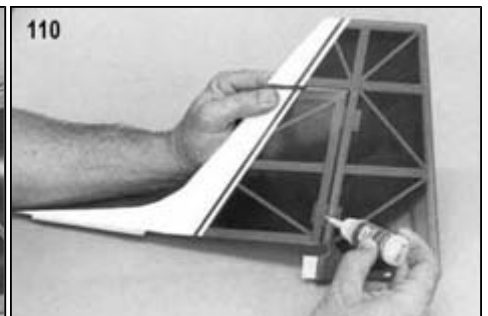

108. Place three or four drops of any brand cyanoacrylate adhesive (thinnest variety) directly onto the EASY HINGE in the gap. You will notice that the glue is quickly wicked into the slot as it penetrates both the wood and the hinge. Continue this process, gluing the same side of all of the hinges. Then turn the surfaces over and repeat the gluing process on the other side of each hinge.

109. After the glue has cured, approximately three minutes, the joint can be flexed. You may notice a slight stiffness in the joint. This can be eliminated by flexing the surface to full deflection each direction a couple of dozen times. Don't worry about shortening the life of the hinge as they are almost indestructible.

110. Hinge the rudder to the fin in the same manner as above. However, do not glue the bottom hinge of the rudder at this time, this will be done in the final assembly when the fin is glued in place on the fuselage.

FINAL ASSEMBLY

111. Back in Step 10 of the fuselage construction you drill holes in the fuse sides for the 3/16" birch dowels that hold the wing on when standard rubber band mounting is used. Now you can epoxy the dowels in place. The wing dowels can be painted a matching color with enamel or dope.

112. Cut away the covering material from the bottom of the stab where it will contact the fuselage. Then epoxy the stab in place on the fuse. Use slow drying epoxy to allow you ample time to carefully align the stabilizer with the fuse and wing. Check the alignment of the stab to the wing from the front and top before the glue dries. Mount the wing on the fuselage, step back about 10 feet and view the model from the front. Tilt the stab slightly if necessary. Use a tape measure to insure that the wing and stab are at equal distance and parallel to each other. Use pins to hold the stab securely in position until dry.

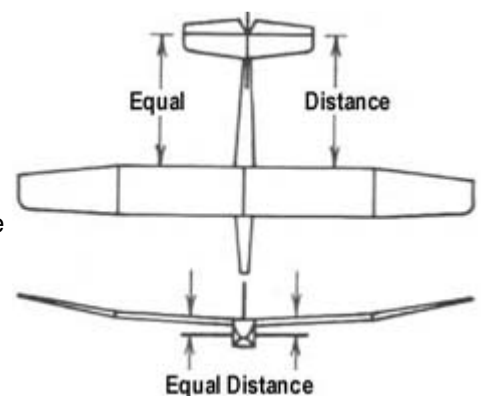

113. Set the fin/rudder assembly in place on the fuselage. Cut a hinge slot in the rear of the fuselage for the bottom rudder hinge.

114. Epoxy the fin permanently onto the stabilizer and into the die-cut slot in the fuselage top at the same time. Also, insert the bottom rudder hinge into the fuselage when gluing the fin in place. Use a triangle to align the fin with the stabilizer, pin securely in place, and allow to dry. Glue the bottom hinge into the rudder and fuselage with thin variety CA glue, as was done for all the other hinges.
115. Draw a pencil line down the center of the fuselage bottom to help align the ABS plastic skid. Apply double coated foam servo mounting tape to the plastic skid, remove the paper backing from the tape, and press the skid into place.
NOTE: The ABS plastic skid can be painted a matching color with either enamel or dope.
116. To complete the installation of the nylon elevator pushrod, first cut one of the 2-56 x10" threaded rods provided to 2-1/2" overall length, measuring from the threaded end. Then put a "Z" bend (or an "L" bend if you are going to use a pushrod keeper) in the non threaded end of the rod.

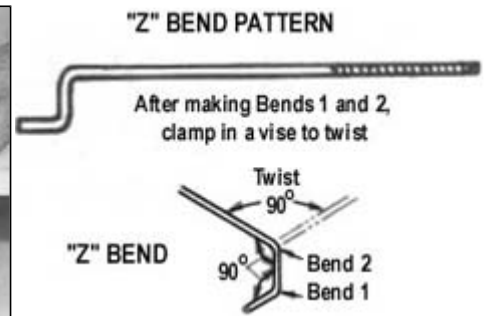
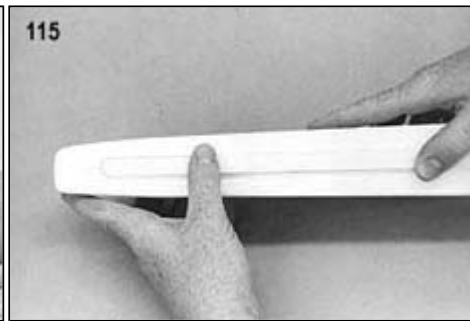
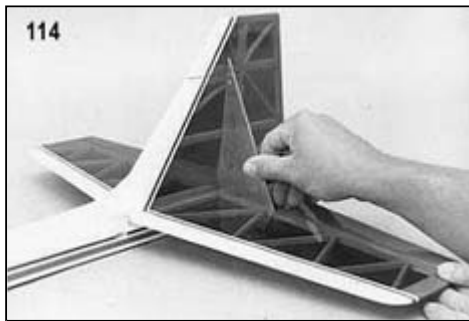

117. Screw the threaded end of the wire approximately 1-1/4" into the 1/8" o.d. nylon inner pushrod tubing that goes inside the larger tube that was perviously installed in the fuselage.

118. Slide the inner pushrod tubing into the outer tubing from the servo end. Install the "Z" bend through the servo arm and hook it up to the servo.

NOTE: It may be necessary to trim the servo arm down to prevent it from rubbing on the side of the fuselage.



119. Two nylon control horns have been supplied for the elevator and rudder. Install the control horns on the control surfaces with #2 x1/2" sheet metal screws. Mount one horn on the left side of the rudder and the other horn on the bottom of the right elevator.

120. With the elevator servo neutralized, and the elevator level, cut off the protruding end of the inner pushrod tube 1-1/4" from the control horn. Then cut one of the 2-56 x10" threaded rods provided to 4-1/2" overall length, as measured from the threaded end. Slide the unthreaded end of the rod completely into the inner pushrod tube and then screw in about 3/16" of the threaded portion. Install the nylon R/C link and hook the pushrod up to the control horn.

Repeat Step 120, to finish the end of the rudder pushrod.

121. Adjust your elevator pushrod linkage to achieve 3/4" up and 3/4" down elevayot movement with the full throw of the transmitter stick. The trim should be set in the neutral position.

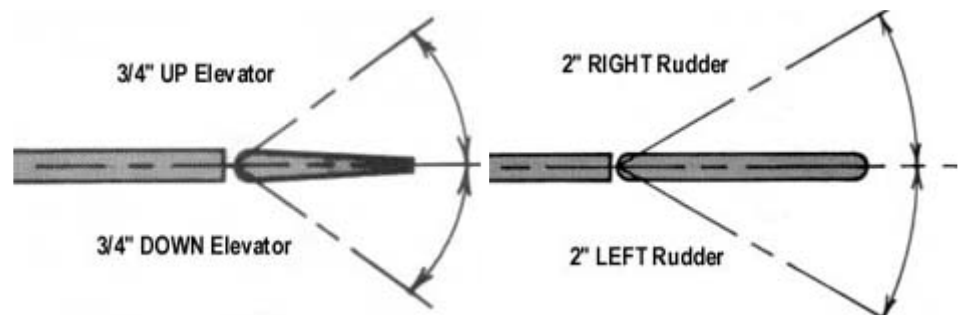

122. Adjust the rudder pushrod linkage to achieve 2" of left and 2" of right rudder movement. The trim should be set in neutral position.

123. The installation of the spoilers can now be completed. Two 3/64" x 1-3/8" wires, with a loop in one end, are provided for making spoiler actuator wires. Finish shaping these wires by bending them with pliers to match the pattern shown. Then epoxy one of the wires in place on the bottom of each spoiler, directly in line with the end of the plastic tubing in the wing.

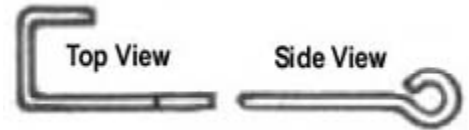

124. Two 1/2"x3/4" pieces of lead are provided for spoiler closing weights. Use the double coated servo mounting tape provided to stick one piece of lead on the bottom of each spoiler.

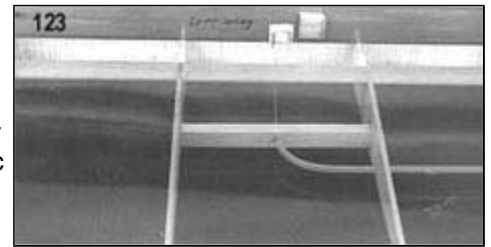

125. Hinge the spoilers permanently in place. We prefer to use plastic trim tape or clear vinyl tape as a spoiler hinge. We do not recommend using heat-shrinkable plastic covering material as a hinge because it can tighten up in the hot sun and cause the spoilers to bind. Trim tape is slightly thicker and not as easily affected by the sun. To hinge the spoilers, simply set them in place in the center of the cut out in the wing. Tape the leading edge of the spoiler to the front of the cut out with two 1" long pieces of tape, applied near the ends of the spoiler, on the top only.

126. Six feet of thin dracon line is provided for actuating the spoilers from a servo mounted in the fuselage. Cut the dracon line into two 3 foot long pieces. Feed the dracon line through the plastic tubing in the wing.
HINT: The easiest way to do this is to take a long piece of 1/32" or smaller music wire (not provided) and feed it through the tube first. Then make a tight hook in the end of the wire, tie the dracon line to the hook, and pull the wire and line back through the tubing. Tie the end of the dracon line to the actuator wire mounted on the bottom of the spoiler.

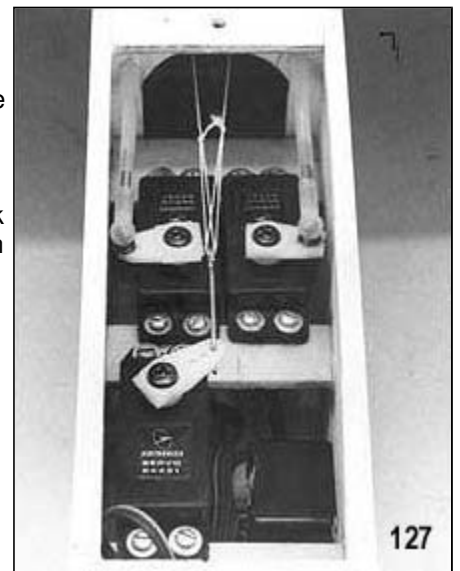

127. Use the remaining 3/64"x1-3/8" wire with the loop in one end to make a hookup wire for linking the dracon line to the servo output arm. Put a "Z" bend in the end of the wire and install it in the servo arm. Then tie a loop in the end of the dracon lines coming from each wing panel and loop both lines over the hookup wire. Hold the wing in place on the fuselage and operate the spoiler servo with the throttle stick of your transmitter. Both spoilers should come open at the same time and should open the same amount. You will undoubtedly have to readjust the length of the dracon lines several times before getting them perfect, so don't tie the knots too tight at first.

128. A 4-40 x 8" threaded rod is provided for making the towhook. Cut the threaded rod to 2" overall length, measuring from the threaded end. File or grind the cut end smooth. Next use pliers to bend the threaded rod to match the pattern here. Screw a 4-40 hex nut on the threaded end, add a flat metal washer, and then screw the towhook into the blind nut in the fuselage.

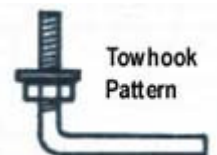

Airplanes Must Be Straight And Balanced (or straighten up and fly right!)

One of the secrets to a good flying model is to make sure the wing is straight and the model is properly balanced. Check to make sure there are no warps in the wing. If there are, twist the wing in the opposite direction of the warp and apply heat to both sides of the covering material, starting on the side opposite the warp. Hold until the covering cools, then recheck for straightness. Try again if necessary. It is helpful to have a friend assist you with this procedure.

The spanwise balance of the wing is an often overlooked but essential part of balancing a model. Place your assembled RISER 100 wing on a flat table with both wingtips equal distance above the table. Let go and observe which wing panel falls to the table. Add very small amounts of weight to the opposite wing tip until it will balance on the dihedral joint at the center of the wing. Permanently install the weights in the wing tip.

To check the fore and aft balance of your model, mount the wing on the fuselage. The fuselage side view plan shows the location for balancing your RISER 100. The forward location is for the first test flights and for newcomers to the sport of R/C soaring. The rearward location is for more experienced pilots. A more rearward balance point or Center of Gravity (C.G.) will give the RISER 100 a flatter glide but it will also make it more sensitive to control movements. A forward C.G. will make the controls less sensitive and the model more stable for better wind penetration with a very slight loss of thermal capability. Balance your RISER 100 within the recommended C.G. range to suit your needs and style of flying. Move the battery pack fore or aft to achieve the balance point you want. After flying your model, you may want to readjust the final balance to achieve the desired performance. Every model will fly a little different! Do not attempt to fly the model with the balance point too far back.

Pre-Flight

Make sure the servos are securely mounted, the servo arms have their retaining screws in place, and all screws are tight.

Range check your radio as per the manufacturer's instructions and make sure it is fully charged. If there are any problems, send the radio in for repairs.

Double Check Everything You Can Think Of!

A model and radio that is not prepared and working properly on the ground before take-off will not improve in the air - IT WILL GET WORSE! There is no point attempting to fly until everything is 100% correct.

FLYING THE RISER 100

First Test Flight

While it is possible that a R/C sailplane can be mastered by a beginner without any assistance, the odds of success are pretty slim. Don't be too proud to ask for advice and help from more experienced fliers. A little help at the right time from an instructor can get you out of trouble and possibly save your model from a bad crash.

Choose an area that is free of obstructions such as buildings and trees and pick a day when there is little or no wind. Fasten the wing to the fuselage with eight #64 rubberbands. Place six of the rubberbands on parallel to the ribs and crisscross the final two. If your flying site is occupied by other fliers, check with them to be sure that your frequency won't interfere with theirs, and vice-versa.

Turn your receiver and transmitter on and fully extend the antenna. Gently hand toss the sailplane into the wind with the nose pointed slightly down and the wings level. Start by running a couple steps with the model, then release it with a smooth spear throwing action. Aim for a spot on the ground about 50 yards out ahead of you.

DO NOT THROW THE SAILPLANE VIOLENTLY!

If the nose of the sailplane pitches up, feed in some down elevator. If the nose pitches down, feed in some up elevator.

DO NOT OVER CONTROL!

Keep your control movements smooth. If the sailplane veers left, feed in some right rudder. If it veers right, feed in some left rudder. The main thing to remember when flying a sailplane is not to over control. If the model does get out of control, and you have sufficient altitude, a glider is so stable that you can usually just let go of the sticks momentarily and the model will right itself. Many models have crashed because a beginner continued to send the wrong input. On landing, when the sailplane is about two feet from the ground, make sure the wings are level and start slowly feeding in some up elevator to slow the model and establish a gentle descent. The model should settle onto the ground in a slightly nose high attitude.

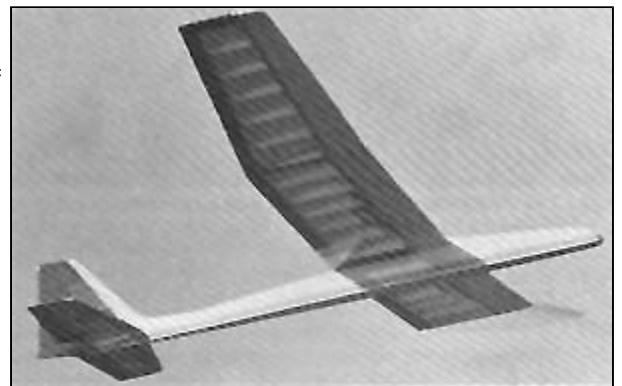

After each test flight, readjust the R/C links on the pushrods so that the trim levers on the transmitter can be returned to a neutral position. It may take several flights to completely trim out the model.

Thermal Soaring

Thermal soaring is by far the most popular type of R/C soaring. It is not uncommon to see two or more sailplanes riding the same thermal, all of them circling for altitude and staying in the thermal. A thermal is a rising column of hot air - air that has been overheated by the sun radiating off dark areas of ground such as roads, plowed fields, buildings, etc. Thermals can be found year around and just about anytime of the day. However, the most active time for thermals is during the spring and summer months with mid-morning to mid-afternoon being the best time of day to find them. Thermals are easy to detect on days when the wind is light. Many times you can feel the temperature difference when the warm thermal air passes by you. Often a low fluffy cumulus cloud indicates the location of a thermal. Also watch for large birds (hawks, gulls, eagles, buzzards, etc.) circling and maintaining their altitude without flapping their wings. They are riding a thermal!

Thermals are normally small near the ground and tend to increase in diameter the higher up they go. To get into a thermal, we must first gain some altitude. There are two commonly used methods of launching a sailplane into the air.

HIGH-START:

A high-start is made up of surgical tubing and nylon cord. Its purpose is to "sling-shot" the glider into the air like a large rubber band launched model. High-starts come in several different sizes to match the class of the sailplane being flown - a standard class hi-start is recommended for the RISER 100. The standard class high-start usually consists of 100 feet of rubber surgical tubing and 350 feet of nylon cord (although some brands may differ slightly). The surgical tubing is fastened to a stake pounded into the ground. The other end of the tubing is then tied to the nylon cord, while the other end of the nylon cord has a small parachute attached to it. The high-start is layed out on the ground directly into the wind. The parachute end of the high start is attached to the sailplane's towhook. Start walking backwards with the model, stretching the high-start as you go. Go back until the high-start has been stretched to a maximum of 800 feet.

With the sailplane pointed at the stake, raise the nose to approximately 30 degrees and level the wings. Firmly toss the sailplane into the air. Feed in a small amount of up elevator after the launch and the sailplane will begin to climb to the maximum height of the high start. If the sailplane veers to the left or right correct it with opposite rudder. **DO NOT OVER CONTROL!** If it constantly veers from side to side and is hard to control, you are probably holding too much up elevator. Back off a little to regain good directional control. As the sailplane reaches the top, the line should drop off by itself. If it doesn't, feed in a little down elevator to allow the sailplane to dive slightly and the line will fall off. Pull back on the elevator to level off so you can start trimming for the flattest glide.

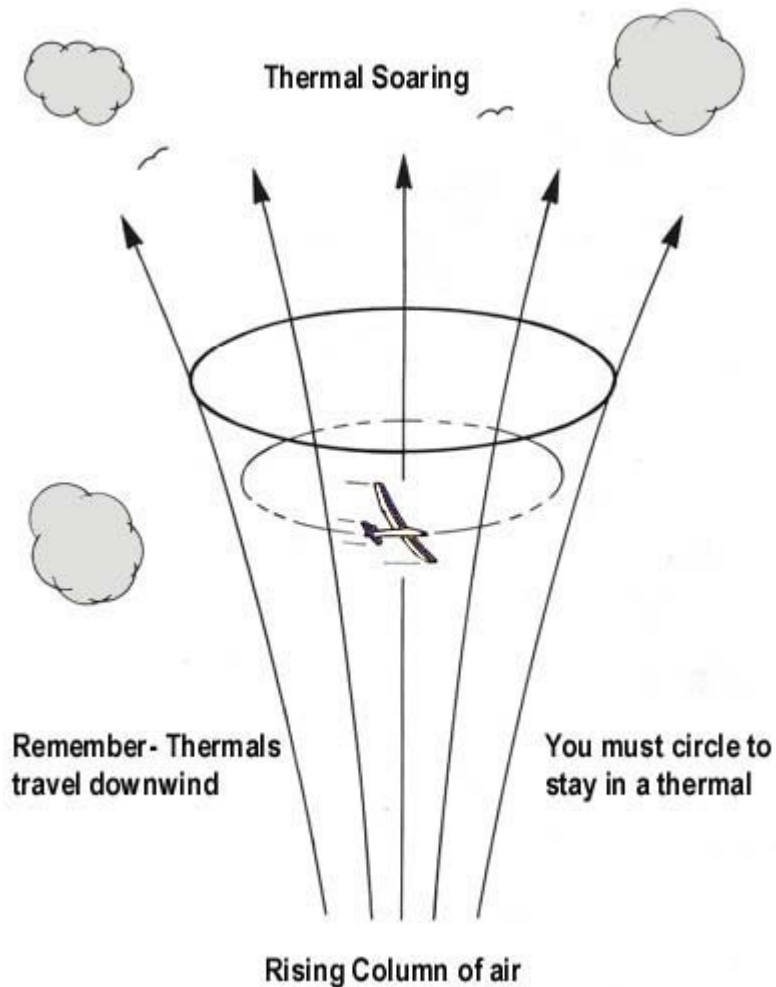

WINCH:

A winch is a battery operated device that uses an electric motor to drive a large spool that reels in the long towline. There is no rubber surgical tubing involved. As the line is reeled in, it pulls the sailplane up to altitude. The speed of the winch is normally controlled by the glider pilot using a foot pedal as he flies the model with his hands. Most competition oriented sailplane enthusiasts prefer a winch launch over a high-start simply because they can control the speed that the line is reeled in and thus better control the speed and pull on their model.

Now that the sailplane is at altitude, it is time to go thermal hunting. Start by trimming the RISER 100 for a nice flat glide and head upwind flying a zig-zag pattern. Never cover the same ground twice while searching for thermals. Be looking for areas where you can see heat waves radiating up, or hawks circling, or swirling "dust devils" being picked up off the ground. Remember, smooth flying is the secret to long flights. Watch the sailplane closely as it is flying. If it suddenly seems to "rise up on a step", stops sinking and starts gaining altitude, you know you are in a thermal. Or if you see one wing or the other bump up, immediately turn towards the high wing to try to get into the thermal that caused the bump. Once you are in a thermal, feed in a small amount of rudder trim to set the sailplane up for a large glide circle of approximately 100 to 200 feet diameter. As the sailplane continues to gain altitude, you can open up the glide circle slightly. Once in the thermal, do not let the sailplane get so far downwind that you can't get it back to the field if the lift dies out.

Slope Soaring

Slope soaring is a unique sport in itself and probably the fastest growing aspect of R/C soaring. Wherever you can find a decent size hill with a 1015 m.p.h. wind blowing into it, you can slope soar. When the wind is blowing into the face of the hill, it is deflected upward by the slope of the hill. This upward rising air is the lift we use to soar on. Wind velocity and the amount of slope in the hill will determine the amount of lift generated by a particular site. The amount of lift can also be affected by obstructions such as trees, buildings, etc. So try to pick a hill with a long smooth approach to it that is free of obstructions.

Although there are many special aerobatic slope soaring designs around, the RISER 100 can give a pretty good account of itself at slope soaring for duration. The only addition you need to make to your RISER 100 for slope soaring is to add some ballast to help it penetrate the wind. Depending upon the actual velocity of the wind on the day you are flying, try adding 6 - 12 ounces of weight inside the fuselage directly over the C.G.

Launch the sailplane out over the crest of the hill by throwing it with the wings level and with the nose of the sailplane pointed slightly down. Fly the sailplane parallel to the slope, and when you need to turn around, always make your turns into the wind, away from the slope.

Use smooth control movements and fly the sailplane back and forth across the slope staying in the lift. Never turn downwind, into the slope until you decide it is time to land. When landing, make sure that you have a fair amount of altitude, then fly the sailplane behind the slope, and make a gentle descent to a landing on top of the hill. If you are too high on your landing approach, make S-turns to lose altitude or go around.

It will take a little practice to master the art of slope soaring, but it is well worth the effort and a lot of fun.

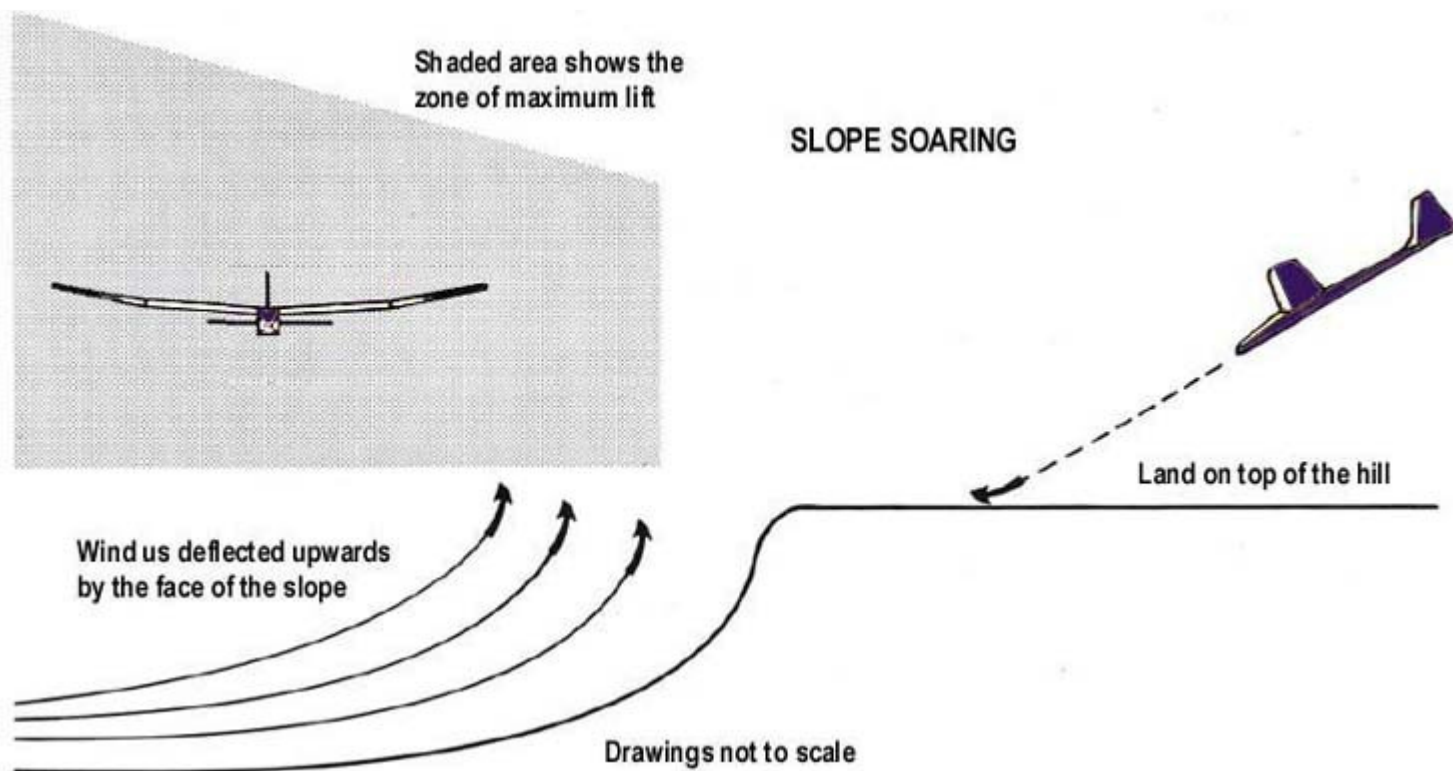

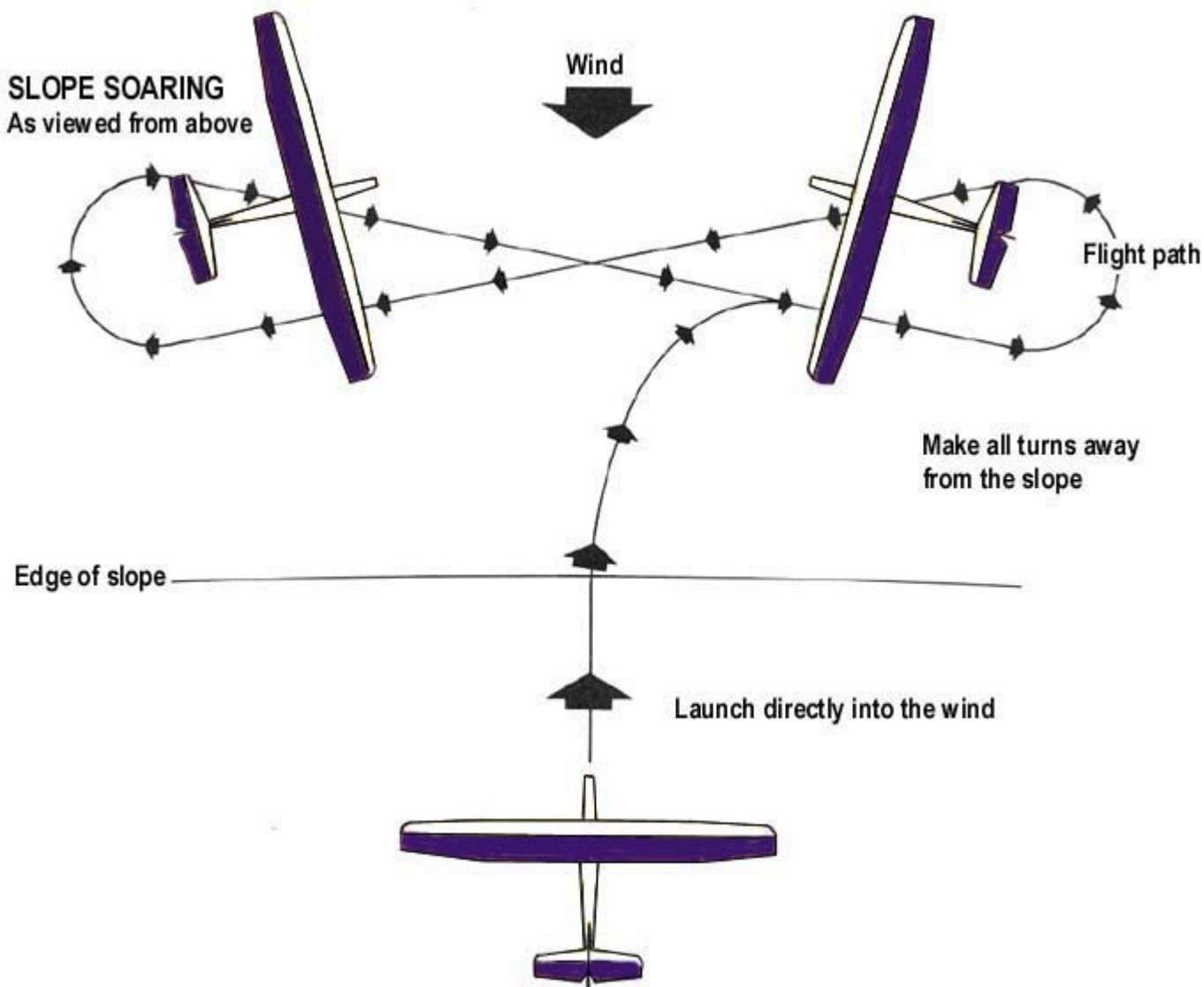

If you have any technical questions or comments about this kit, or any other SIG product, please call us.

SIG MODELER'S HOTLINE

1-800-524-7805

Weekdays, 7:00am - 4:30pm Central

© Copyright SIG Mfg. Co., Inc.

SIG MFG. CO., INC.....Montezuma, Iowa 50171-0520

LIMIT OF LIABILITY:

In use of our products, Sig Mfg. Co.'s only obligation shall be to replace such quantity of the product proven to be defective. User shall determine the suitability of the product for his or her intended use and shall assume all risk and liability in connection therewith.