

HOG-BIPE



BUILDING AND FLYING INSTRUCTIONS

SIGRC69

Introduction

In order for your HOG-BIPE to fly as well as it was designed to, it must be carefully assembled. A model airplane that is not built properly will not fly properly! Remember to work slowly and follow the instructions exactly. SIG, as the kit manufacturer, can provide you with a proven aerodynamic design, quality materials, and detailed instructions, but ultimately the flyability of your finished model depends on how well YOU put it all together.

Customer Service

Sig Mfg. Co. is totally committed to your success in building and flying the HOG-BIPE. Should you encounter any problem building this kit, or find any missing or damaged parts, feel free to contact us by mail or telephone.

SIG MFG. CO., INC.

P.O. Box 520
401 South Front Street
Montezuma, IA 50171-0520 USA

PHONE: (641) 623-5154 FAX: (641) 623-3922

SIG WEB SITE: www.sigmg.com

SIG E-MAIL: mail@sigmg.com

WARNING! THIS IS NOT A TOY!

Flying machines of any form, either model-size or full-size, are not toys! Because of the speeds that airplanes must achieve in order to fly, they are capable of causing serious bodily harm and property damage if they crash. IT IS YOUR RESPONSIBILITY AND YOURS ALONE to assemble this model airplane correctly according to the plans and instructions, to ground test the finished model before each flight to make sure it is completely airworthy, and to always fly your model in a safe location and in a safe manner.

The governing body for radio-control model airplanes in the United States is the ACADEMY OF MODEL AERONAUTICS, sometimes referred to as the AMA. The AMA SAFETY CODE provides guidelines for the safe operation of R/C model airplanes. While AMA membership is not mandatory, it is a good idea and we encourage all new R/C fliers to join the AMA. Membership in the AMA provides you with important liability insurance protection in case your R/C model should ever cause serious property damage or personal injury to someone else.

For more information, contact: ACADEMY OF MODEL AERONAUTICS
5161 East Memorial Drive Muncie, IN 47302
Phone: (765) 287-1256

COMPLETE KIT PARTS LIST

Die-Cut Balsa

1	3/32"x3"x18" Die-Cut Sht.1;W-1T Balsa Wing Ribs	1	3/32"x3"x18" Die-Cut Sht.2;W-1B, W-2 Balsa Wing Ribs	8	3/32"x3"x18" Die-Cut Sht.3;W-2 Balsa Wing Ribs	1	3/32"x4"x15" Die-Cut Sht.4; F-1A,F-2,F-4,F-5A,SBR-1,SBR-2,WTR
---	---	---	--	---	--	---	---

Balsa Sheet

1	1/16"x3"x48" Leading Edge Sheeting (Top Wing)	6	1/16"x3"x24" Leading Edge Sheeting (Top & Bottom Wing)	4	1/16"x1-1/4"x24" Trailing Edge Sheeting (Bottom Wing)	2	1/16"x1-1/4"x48" Trailing Edge Sheeting (Top Wing)
4	1/16"x3"x30" Stabilizer Sheeting	4	1/16"x3"x30" Fuselage Top Deck Sheeting	1	1/16"x4"x36" Wingtip Sheeting	3	1/16"x2"x36" Wing Center Sheeting

Balsa Sticks

2	1/4"x1/4"x36" Stabilizer Frame	1	1/4"x1/2"x48" Main Spar (Top Wing)	8	1/4"x1/2"x24" Main Spars (Bottom Wing), Stabilizer Leading Edge	1	1/4"x1/2"x36" Stabilizer Trailing Edge, Fin Post
2	1/4"x3/4"x48" Wing Trailing Edge	5	3/16"x3/16"x36" Top Deck Stringers	6	1/16"x1/4"x36" Cap Strips	1	1/16"x1/2"x36" Cap Strips
1	1/2" Trianglex24" Braces for Firewall, Bottom Wing Mount Blocks, Landing Gear Plate	1	1/4" Trianglex12" Brace for Top Wing Mount Plate	1	1/4"x1"x15" Cowl Fairing Blocks		

Balsa Blocks

2	5/8"x5/8"x6" Tail Fairing Blocks						
---	----------------------------------	--	--	--	--	--	--

Special-Cut Balsa

2	1"x1"x3" B-5 Bottom Wing L.E. Blocks	1	1"x1"x1-1/2" B-4 Top Wing L.E. Block	1	1/2"x1-1/2"x8" Top Wing Center Section T.E.	2	1/2"x1-1/2"x2-1/2" Bottom Wing Center Section T.E.
2	5/16x48" Leading Edge	4	1/2"x1-1/2"x24" Ailerons	2	3/8"x3"x12" Elevators	1	1/4"x3"x12" Rudder
18	1/16"x2-13/16"x1-1/8" Spar Webbing						

Sawn Plywood							
2	1/32"x1"x2" Birch 3-ply; P-9 Wing Bolt Plates						
Laser-Cut Parts							
1	1/4" 5-ply Birch Firewall	1	1/4" 5-ply Birch Landing Gear Plate	1	1/16" 3-ply Birch P-6 Top Cabane Mount Plate	1	1/16" 3-ply Birch P-7 Center Cabane Mount Plate
1	1/8" 3-ply Birch P-8 Bottom Cabane Mount Plate	1	1/8" 3-ply Birch DB Dihedral Brace	1	1/8" 3-ply Birch TWB Top Wing Brace	1	1/8" 3-ply Birch F-3B
2	1/8" 3-ply Birch P-5 Wheel Pant Plates	2	1/8" 3-ply Birch P-3 I-Strut Bottom Mount	2	1/8" 3-ply Birch P-2 I-Strut Top Mount	2	1/8" 3-ply Birch P-1 Top Wing Mount Plate
2	1/8" Lite-Ply Fuselage Sides	4	1/8" Lite-Ply Wingtip Supports	1	1/8" Lite-Ply FTF Fuselage Top Front	1	1/8" Lite-Ply FBF Fuselage Bottom Front
1	1/8" Lite-Ply FBR Fuselage Bottom Rear	1	1/8" Lite-Ply TWM Tailwheel Mount	1	1/8" Lite-Ply Tank Floor	4	1/8" Lite-Ply Wingtips
4	1/8" Lite-Ply P-4 Cabane Mount Supports	2	1/8" Lite-Ply Fuselage Doublers	1	1/8" Lite-Ply F-5B Pushrod Support	1	1/8" Lite-Ply Stab Mount
2	1/8" Lite-Ply I-Struts	1	1/8" Lite-Ply F-3	1	1/8" Lite-Ply F-5	1	1/8" Lite-Ply Dihedral Gauge
1	1/8" Lite-Ply F-6	1	1/8" Lite-Ply F-7	1	1/8" Lite-Ply F-8	1	1/4" Balsa S-1
1	1/4" Balsa S-2	2	1/4" Balsa S-3	1	1/4" Balsa F-1	1	1/4" Balsa F-2
1	1/4" Balsa F-3	8	1/4" Balsa WTB Wingtip Blocks				
Hardwood							
2	1/2x5/8x1-1/8" Maple; B-1 Top Wing Mount Blocks	2	1/2"x3/4"x1-5/8" Basswood; B-2 Bottom Wing Mount Blocks	4	3/8"x1-1/4"x3/4" Basswood; B-3 Cabane Mount Blocks	1	3/8"x3/8"x12" Basswood; Servo Rails
2	1/4" Dia.x1-1/2" Wing Dowels						
Wire Parts							
6	2-56x10" Threaded Rods; Elev, Rud, Ail Pushrods	2	4-40x8" Threaded Rods; Aileron Interplane Pushrods	1	1/16" Dia. Tailwheel Wire, bent	1	1/8" Dia. Elevator Joiner Wire, bent
2	4-40 Aileron Torque Rods, bent 1 left & 1 right						
Hardware							
4	#2x3/4" Sheet Metal Screws; Elev, Rud Horns	8	#2x1/2" Sheet Metal Screws; Aileron Horns	2	#4x1/2" Sheet Metal Screws; Tailwheel Bracket	4	4-40x3/4" Pan Head Bolts; Cabane Strut Mounts
4	4-40x3/8" Mounting Bolts: Wheel Pants	3	6-32x1/2" Mounting Bolts; Landing Gear	4	6-32x1" Mounting Bolts; Motor Mounts	2	8-32x1-1/2" Mounting Bolts; Axles
6	8-32 Hex Nuts; Axles	2	4-40 Hex Nuts; Aileron Interplane Pushrods	14	4-40 Blind Nuts; Cabane Struts, I-Struts, Wheel Pants	7	6-32 Blind Nuts; Motor Mounts, Landing Gear
2	8-32 Blind Nuts; Top Wing Mount	10	#4 Flat Metal Washers; Cabane Struts, I-Struts	2	#8 Flat Metal Washers; wheel spacers	2	#2 Flat Metal Washers; Tailwheel retainers
4	Nylon Interconnect Horns For Ailerons	1	Medium Nylon Control Horn (RIGHT); Rudder	1	Medium Nylon Control Horn (LEFT); Elevator	2	8-32x1" Nylon Bolts; Top Wing
2	1/4-20x1" Nylon Bolts; Bottom Wing	6	4-40x3/8" Socket-Head Bolts; I-Strut Mount	2	4-40 Nylon Aileron Connectors	1	Nylon Tailwheel Bracket
4	2-56 Nylon R/C Links; Control End of Rud, Elev, Ail Pushrods	5	2-56 Solder Links; Servo End of Rud, Elev, Throt, Ail Pushrods	2	4-40 Solder Links; Ail Interplane Pushrods	2	4-40 Metal R/C Links; Ail Interplane Pushrods
2	Glass-Filled Motor Mounts						
Plastic Parts							
1	.070 ABS Molded Headrest	1	Set .070 ABS Molded Wheelpants				
Miscellaneous							
1	.090 Tempered Aluminum Main Gear, formed	2	.060 Un-Tempered Aluminum Cabane Struts, formed	1	.030 3-1/2"x8" Clear Plastic Sheet; Windshield	2	.200 O.D.x36" Nylon Inner Pushrod Tubing; Elev, Rud
2	.270 O.D.x36" Nylon Outer Pushrod Tubing; Elev, Rud	1	.130 O.D.x18" Nylon Inner Tubing; Throttle Pushrod	1	1/16" Dia.x18" Steel Cable; Throttle Pushrod	1	3-piece Pushrod Connector Assembly; Carb End of Throttle Pushrod
1	1"x24" Fiberglass Tape; Bottom Wing Center Joint	1	2"x6" Fiberglass Tape; Cabane Mount	27	Easy Hinges	1	Full-Size Plan Plate #1
1	Full-Size Plan Plate #2	1	Photo-Illustrated Instruction Book	1	7-3/4"x10" Decal Sheet	1	7-1/2"x27" Decal Sheet

Wood Parts Identification

Wood parts such as standard stick and sheet stock, leading edges, trailing edges, ailerons, elevator, etc., are all easily identifiable by comparing their shape and dimensions to the plans and the "HOG-BIPE COMPLETE PARTS LIST"; therefore we did not feel that there was any need to label these parts. On the other hand, proper identification of the different wing ribs, wing sheeting, fuselage formers, etc., can be confusing because some of them are very similar looking, but in fact they are quite different. Wherever possible, we have labeled (printed) these parts.

Key To Laser-Cut Parts

Thirty-Eight of the HOG-BIPE parts are laser-cut and do not have their part name/number pre-printed on them. Use a pencil to mark each of the laser-cut parts according to these diagrams.

NOTE: The edges of all the laser-cut parts have a "burnt" appearance varying from light brown to dark black, depending upon the thickness and type of material the part is made of. Our tests indicate that a slight discoloration of the edges does not significantly affect the bonding ability of these parts. However we recommend that the black edges of former F1, made of 1/4" thick plywood, be lightly sanded with an 80 grit sanding block to remove the loose black soot. It's not necessary to sand every bit of black off (you don't want to change the size of the part). Sand until you can run your finger lightly over the edge without picking up any black color (see photos of sanded F1 in the fuselage section).

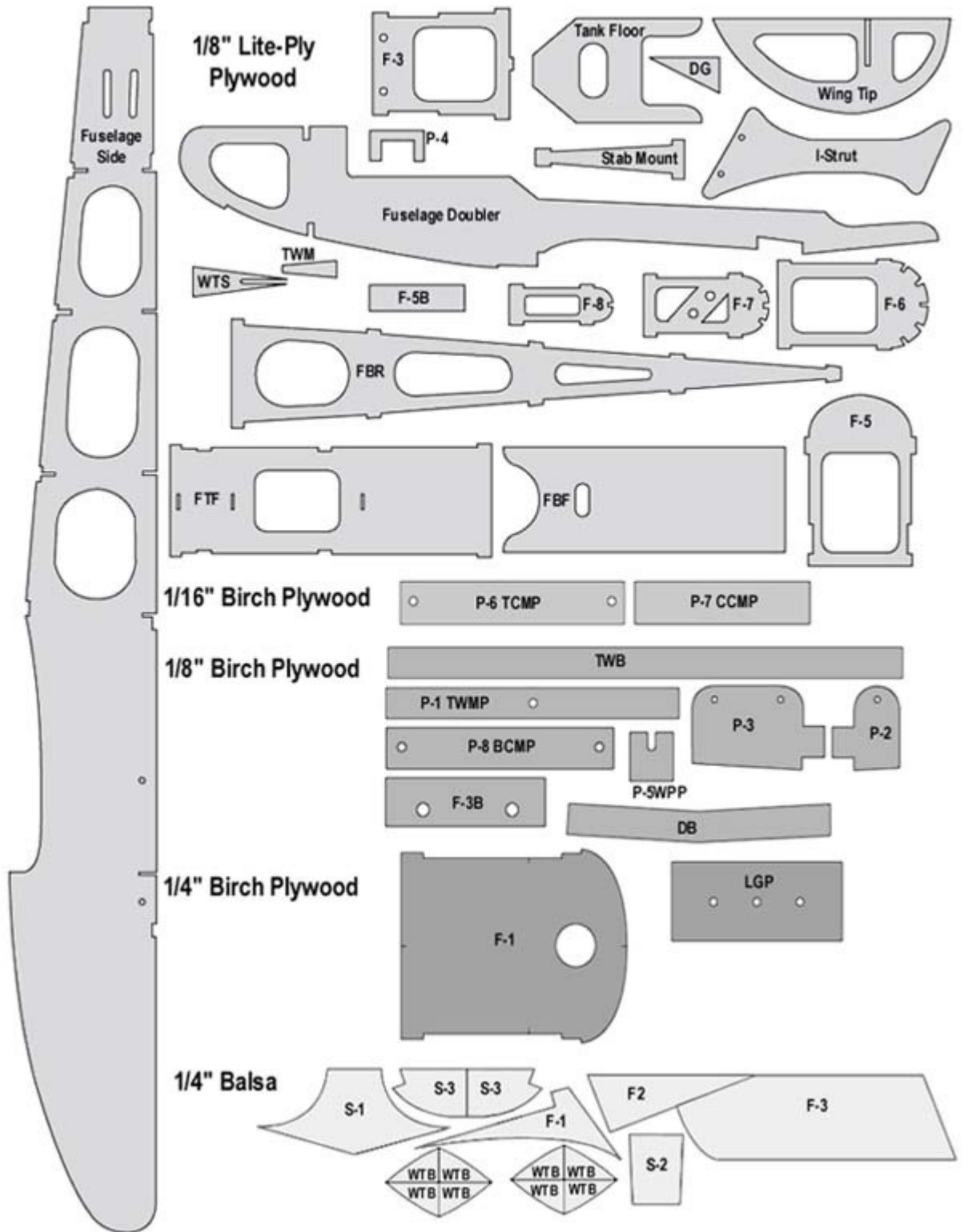

About The Wood In The Kit

We strive to supply good quality materials in all SIG kits. However wood is a highly variable material (unlike man-made plastic or metal), so every single wood part in a kit will probably not have flawless appearance. Often things that look like an imperfection are actually quite acceptable when you consider the function the part will serve. Mineral stains and tiny knots do not seriously affect balsa wood strength. Also, there is a natural tendency for some balsa sticks and sheets to immediately bow upon being cut off from a perfectly square block due to internal stresses in the wood. In most cases, bows in wood parts (such as leading edges) readily straighten out as they are glued into a structural unit. Likewise Lite-Ply fuselage sides, formers, and doublers that are warped will usually straighten right out when they are glued in place. If you are in doubt about the suitability of any part in your kit for its intended purpose, call or write to us for assistance and/or a replacement part.

Additional Components Needed

The following items are not supplied in this kit but are needed to complete the HOG-BIPE. Because of the wide variety of brands available and the influence of personal preferences, the choice of these items is left to the builder to select. All of these items are available from your local hobby shop.

- **.60 to .65 cu. in. 2-Stroke Glow R/C Engine w/Muffler, or .65 to .80 cu. in. 4-Stroke Glow R/C Engine w/Muffler 12 oz. fuel tank, 3 inch main wheels, and one inch tail wheel.**

Engines larger than those listed are not recommended! Use of oversize engines will cause balance problems and may overload the structure of the airplane. Any normally ported .60 2-stroke glow R/C engine will provide adequate power to fly the HOG-BIPE. We believe that the .65 2-stroke glow R/C engine will be the most commonly used engine in the HOG-BIPE, so that is what we've shown on the full-size plans and in these instructions.

- **Radio Control System**

You will need a (minimum) 4-channel radio control system with 4 servos to operate the ailerons, elevator, rudder, and engine throttle of your HOG-BIPE. The HOG-BIPE's fuselage is spacious enough that any common brand of radio equipment with standard size servos and battery pack can be used. Be certain that your radio system transmits on one of the FCC-approved frequencies for R/C model aircraft.

- **1/2" x 8" x 12" Soft Foam Rubber (such as SIGRF240)**

Used to protect your radio receiver and battery pack from damaging engine vibration. Also used as packing around the fuel tank and radio components to keep them from shifting around in flight.

- **Light-Weight Wood Filler**

For filling holes, nicks, and dents after assembly of the model, but before covering. Regular household "wall repair" or "spackling" compound (3M, Red Devil, DAP, etc.) works well for this. There are also several excellent "model fillers" available at the hobby shop. Just make sure whatever you use is light weight and sands easily. Do not use household patching plaster - it's way too heavy!

- **Glue**

There are so many different types of glue available today for model airplane construction that it can be confusing to even the experienced modeler. To simplify matters, most model airplane glues can be classified as one of four basic types:

1. **Cyanoacrylate Adhesives**, such as SIG CA, are very strong and bond in just seconds. Dramatically speeds up building time! Different viscosity's and cure times are available to suit all areas of model construction.
2. **Two-Part Epoxy Glues**, such as SIG-KWIK-SET (5-minute cure) and SIG EPOXY (3-hour cure), are super strong but too heavy for general construction. Often used in high stress areas such as the firewall, landing gear, and wing joiners.
3. **Water-Based Glues**, such as SIG-BOND (aliphatic resin), are very safe and easy to use. Excellent for general construction, although somewhat slow drying.
4. **Solvent-Based Model Cement**, such as SIG-MENT, is the oldest form of traditional model airplane glue. Still used for general construction by some modelers - especially when building super light weight free flight models.

You could build the HOG-BIPE using any of these four basic types of glue. Each type has different characteristics and advantages, and all of them will result in a bond that is stronger than the wood materials being glued together. Often times the choice of which type to use boils down to a matter of personal preference based on past experience. However, if you want to get your HOG-BIPE into the air as quickly as possible, we recommend that you use CA glue for the majority of the assembly of this kit. CA glue is not only fast and strong, but it also makes it possible to do some unique things in the construction sequence. For instance, since CA glue has the ability to penetrate into an already assembled joint, we can first assemble the interlocking fuselage parts "dry" (without glue), then check and adjust the alignment, and finally apply CA to the pre-assembled joints. This makes it very easy to build a straight and true fuselage in a very short time. If the use of CA glues is new to you, please read "TIPS ON USING SIG CA", included in this kit.

- **Building Board - 12" x 50" minimum size**

This can be any flat surface that will accept and hold pins - such as insulation board, foam board (cardboard laminated to both sides of a foam sheet), cork bulletin board, soft plywood, a reject "door core" from the lumber yard, etc. The most important thing is that the board must be perfectly flat and untwisted! Your wings and tail surfaces will be built on this board, and if the board is twisted or bowed, the parts you build on it will assume the same shape and your model will not fly properly.

NOTE: The building board you'll see us using in the photos in these instructions is an 18" x 50" piece of 3/4" thick plywood (perfectly flat!), with a same sized piece of 1/4" thick foam board stuck down on top of the plywood with double-sided sticky tape. The plywood provides the rigidity and flatness we need, and the semi-flexible foam board lays flat on the plywood and gives us a surface to push pins into. All materials were obtained from the local lumber yard. Insulation board or cork sheet would make a good substitute for the foam board, if that is not available.

- **80 and 220 Grit Sandpaper**

We prefer either garnet or silicone carbide type open-coat sandpaper. Use the 80 grit to rough sand and shape parts. Use the 220 grit to fine sand the entire model prior to covering. Sand with the grain of the wood whenever possible. Always use fresh, sharp sandpaper. Sharp sandpaper will cut through glue and hard materials easily, giving an even surface. Dull sandpaper will require more pressure and may gouge the surface.

- **Sanding Blocks**

The instructions will call for you to sand some parts of the model using a "sanding block", which is simply a piece of sandpaper backed up by a solid, flat block of wood, plastic, or whatever. A sanding block will give you a much flatter, truer result than you would get with an unbacked, limp piece of sandpaper held in your fingertips. An assortment of different size sanding blocks are indispensable tools for all model construction. There are many styles of commercially made sanding blocks available in hobby shops, or you can make your own.

A good general purpose sanding block can be made by wrapping a full-size standard 9"x11" sheet of sandpaper around a piece of hardwood or plywood, as shown below. This is the most commonly used sanding block in our workshop! Use screws or thumbtacks along one edge to hold the overlapped ends of the sandpaper in place. Put 80 grit sandpaper on the block during general construction, and then switch to 220 grit sandpaper for final sanding just before covering (or make yourself two of these blocks, one for each grit sandpaper).

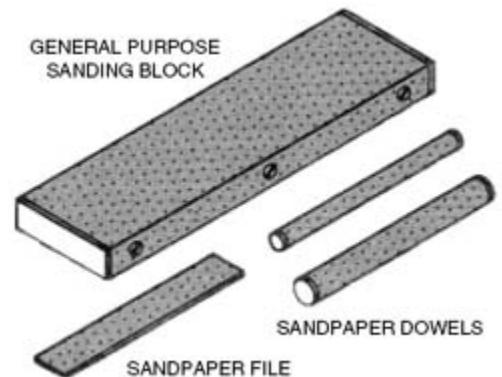

There will be other times when a slightly smaller sanding block is easier to manage. Also, you can make a small sandpaper "file" by simply gluing a strip of 80 grit sandpaper onto a scrap plywood stick. Sandpaper glued or taped to different size hardwood dowels are great for sanding inside curves and holes.

Last but not least, for sanding really large areas, glue 80 grit sandpaper onto a 24" or 36" long piece of aluminum "channel" or "T-Bar" stock (most hardware stores carry a rack of aluminum extrusions in various sizes and shapes).

How To Use These Instructions

Like a full-size airplane, the HOG-BIPE is built by first constructing several basic structures - the FUSELAGE, WINGS, STABILIZER, FIN, etc. - which are then assembled into a completed airplane. These instructions will take you step-by-step through the construction of each basic structure and then the final assembly.

How To Use The Plans

There are two sheets of Plans included in this kit. The plans will be used in several ways. They will help you identify all the parts and determine the relationship of all the parts to each other. They will also be used as a building pattern for the Wing Panels, Stabilizer, and Fin - which will be assembled directly on top of the plans. The plans also show how we would install a typical radio and engine in the HOG-BIPE. By referring to the examples shown on the plan, you should be able to properly install your radio and engine, even if they are not exactly the same as what is shown on the plan.

Everything on the plans is drawn FULL-SCALE, or ACTUAL SIZE (except for the Wing Front view.) to show the correct size, shape, and relationship of all the parts to each other.

FUSELAGE SUBASSEMBLIES

Before starting fuselage construction there are a few subassemblies that should be built and set aside until needed. This is done to avoid interruptions during the flow of the fuselage construction.

NOTE: You need to have the engine that you will be using on hand when working on the firewall. We don't recommend using the motor mounts provided in this kit for any two cycle engine larger than .65 or for any four cycle engine larger than .80.

- 1 a. Using the laser marks draw the vertical and horizontal centerlines that will locate the engine. Use the F-1 cross section drawing on the plan as a guide. Check the width of your engine and determine the spacing needed between the motor mounts. Using the lines on the firewall, locate the mounts, mark the location of the four holes on the firewall and drill the four holes with a 3/16" drill.
- b. Bolt the engine mounts loosely to the firewall with four 6-32 bolts and blind mounting nuts. Double check the location and spacing of the mounts. Now tighten the bolts until the prongs of the blind nuts are started into the wood and holding. Remove the motor mounts from the firewall and seat the blind nuts with a hammer. Spread epoxy glue over the blind nuts to hold them in place. Be careful not to get any glue in the threads of the blind nuts. When dry, bolt the nuts to the firewall.
- c. Glue balsa former F1A on the back of the firewall (same side as the blind nuts).
- d. Using the side view of the plans as a guide position the engine on the mounts so the propeller will clear the fuselage "cheeks" by 1/8" to a 1/4" and mark the engine mounting holes. Keep the as far back on the motor mounts as possible. Remove the mounts from the firewall and drill the holes for the engine mounting bolts. Bolt the engine to the motor mounts, the motor mounts to the firewall and mark the location for the throttle pushrod to pass through the firewall. Allow clearance for the throttle pushrod connector included in the hardware package. Drill an 9/64" hole at this mark for the outer housing of the flexible cable.

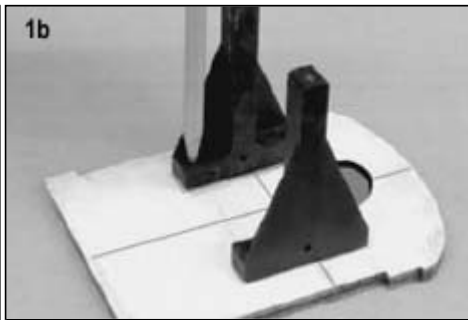

2. Glue balsa former F-5A to lite-ply former F-5.
3. A laser cut piece of plywood 1/4"x1-5/8"x3-7/8" is used for the landing gear plate. Bolt the landing gear loosely to landing gear plate with three 6-32 x1/2" bolts and blind mounting nuts. Now tighten the bolts until the prongs of the blind nuts are started into the wood and holding. Remove the landing gear LGM and seat the blind nuts with a hammer. Spread epoxy glue over the blind nuts to hold them in place. Be careful not to get any glue in the threads of the blind nuts.
4. Glue former F-3 to former F3B, making sure the bottom edge lines up. When dry, clean up the two 1/4" holes from F3 through F3B.

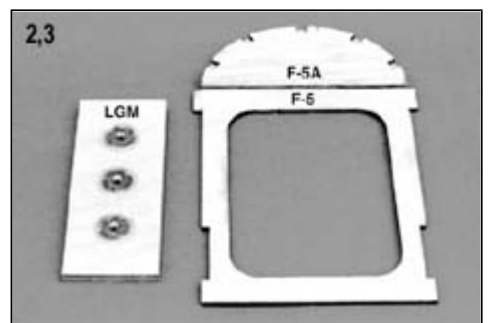

- 5 a. Glue the fuselage doublers to the fuselage sides with slow CA or epoxy. MAKE ONE LEFT AND ONE RIGHT. Keep the sides flat with pins or weights until the glue has cured.

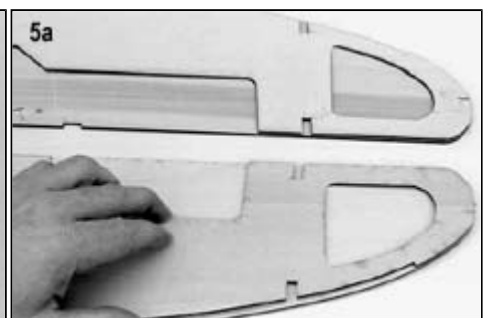
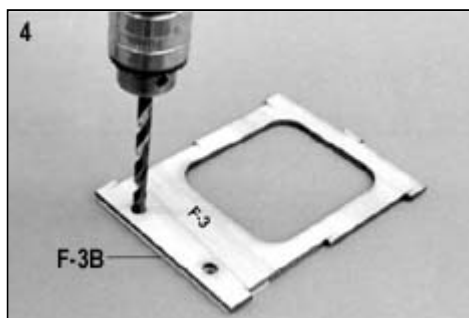

- b. Mark and sand a bevel on the bottom of the firewall to match the angle of the bottom of the fuselage. Make sure the angle is facing the correct direction.

- 5 c. Using the fuselage side view as a guide locate the position of the cabane mount supports (P-4) on the inside of the fuselage sides and glue them in place on the right and left fuselage sides. Be sure to space the four P-4 parts 1/8" from the top edge of the fuselage side. Position the four cabane mounting blocks (B-3) in the four P-4 (flush with the tops of P-4) and glue them in place. Keep the slot in the cabane mounting blocks free of glue.

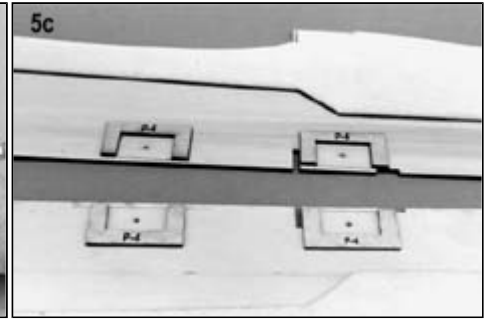

- d. Drill a 9/64" hole through the fuselage side and B-3 at the two holes on each fuselage side. Glue one 4-40 blind mounting nut in each of the four B-3. Clean debris from the slot in each B-3.

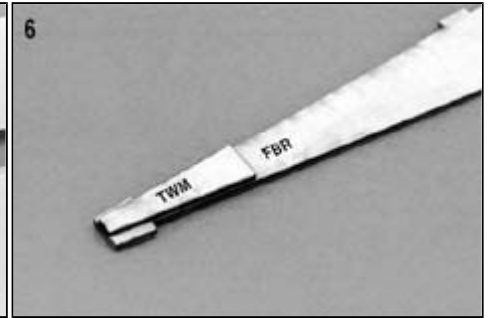
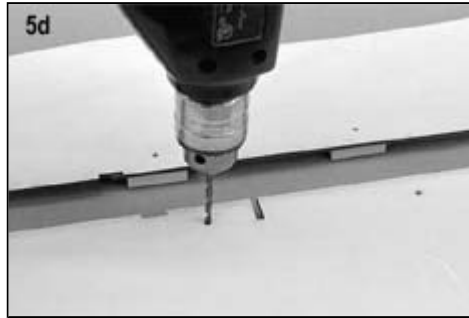

6. Glue the lite ply tail wheel mount (TWM) to the aft end of the fuselage bottom rear (FBR).

FUSELAGE CONSTRUCTION

- 7 a. Using a triangle as a guide glue formers F-1 and F-3 to one of the fuselage sides. Former F-3 is installed with F-3B facing the front of the fuselage. If you look carefully you will see that F-1 has 1-1/2 degrees of downthrust built-in.
- b. After the glue has cured place the other fuselage side on the formers, check for square and parallel and glue in place.
- c. Place fuselage formers F-5, F-6, F-7 and F-8 in place between the fuselage sides. Place a rubber band around the fuselage at each former location to hold everything together tightly. Check that former F-7 is facing the correct way for the pushrod guide holes.
- d. One at a time slide the lite-ply parts fuselage bottom rear (FBR), fuselage top front (FTF) and the stab support under the rubber bands until they all snap into their correct location between the fuselage sides.

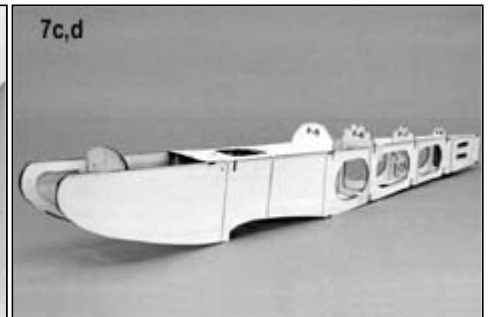
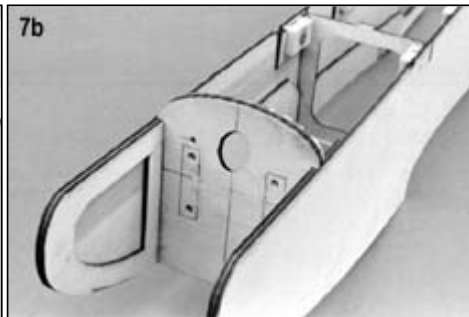
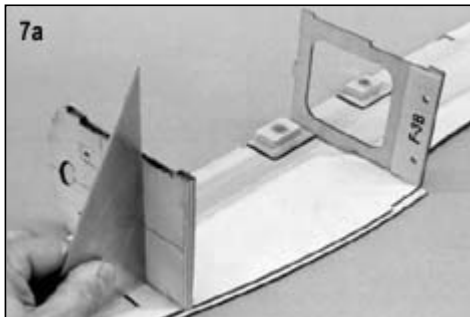

- 8 a. Place the fuselage over the top view of the plans to check the alignment of the parts. Even if some of the plywood parts are badly warped the interlocking design is designed to be self aligning and should pull everything into position. If there are any persistent warps or twists now is the time to fix them. Once the fuselage is glued it can't be straightened. Double check that the opening at the back of the fuselage is square with the fuselage top. If necessary, gently twist or push the parts in the desired direction - use masking tape to hold the correct shape.

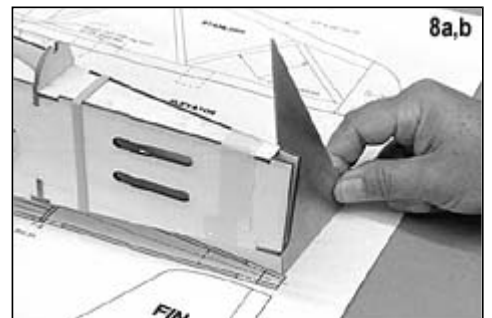

- b. Glue all of the parts permanently in place. Work from the inside of the fuselage, using medium CA. Start with small spots of glue in the corners, rechecking the alignment as you go. Now go back and glue all of the joints on both sides. Leave the rubber bands and tape in place until all of the glue has completely cured.

c. Glue 1/2" triangular stock in the corners between the firewall and the fuselage sides. You may have to notch the triangular stock to clear the blind nuts.



d. Now is a good time to install the tank floor. The height of the floor can be adjusted for different engines, just be sure to leave enough room for the tank. Block the tank in position with pieces of balsa, foam rubber or Styrofoam. If you use an oversize tank it may not be possible to install the tank later on, so hook everything up correctly now. If you use the recommended tank size the tank can be installed after the airplane is covered or painted.

e. Remove the tank and glue in the nylon tubing for the throttle pushrod. Slide the tank back into position, insert the steel cable throttle pushrod and check for any binding. Correct any problems now as you can't get at this area later on.

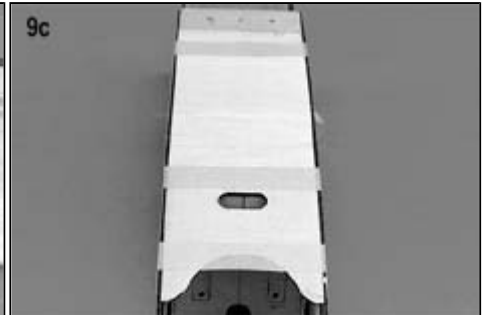
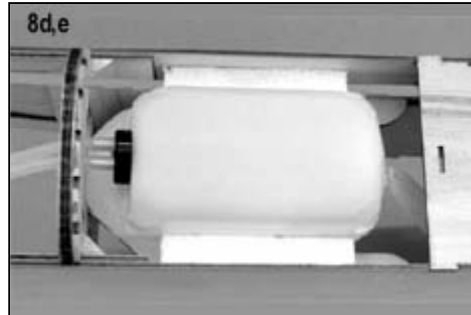

9 a. Install the landing gear plate in the fuselage. Don't be stingy with the glue.

b. Cut two lengths of 1/2" of balsa triangular stock to serve as braces for the landing gear mount and glue in place. Use plenty of glue and get a strong joint. A small fillet will increase the strength and assure you that you have enough glue on this critical area.

c. Tape the fuselage bottom front (FBF) in place and glue with medium CA. Pay particular attention to the joint between FBF and the landing gear mount and glue both the outside and inside of this area.
Note: The hole in FBF is provided to serve as an oil drain hole as well as a convenient place to route the vent line from the fuel tank and/or the breather line from the crankcase of a four-stroke engine.

10 a. Glue balsa formers F-2 and F-4 in the correct slots in FTF.

b. Cut the front stringers to the correct length from 3/16" square balsa and glue in place.

c. Cut the rear stringers to the correct length from 3/16" square balsa. Notice that the center stringer is the only stringer that fits into former F-8. The other two stringers butt against the face of F-8. The lower stringer butt against the face of former F-7. Glue the stringers in place.

d. After the glue has dried sand the stringers flush with the formers, both front and rear.

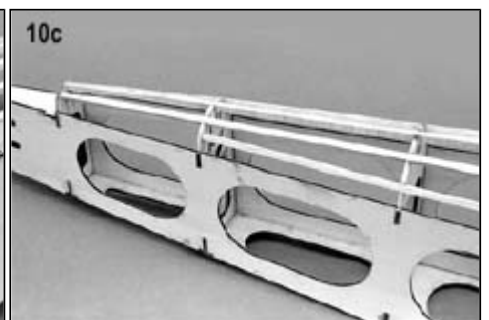
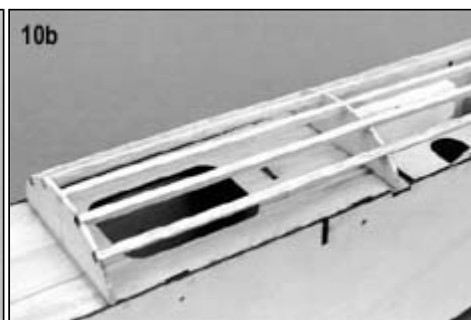
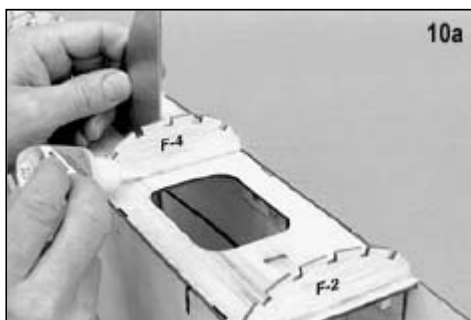

11 a. Roughly trim a sheet of 1/16"x3"x24" balsa to fit the area to be covered. Wet the outside of the sheet with either water, methanol or a weak solution of ammonia and water. Tape the sheet in place over the formers. Do all four pieces of sheeting at once and leave until dry.

b. Sheet the top front of the fuselage using the formed pieces of 1/16"x3"x24" balsa from step 11a. The front sheeting goes from F-1 to F-5. Sheet the top rear of the fuselage using the formed pieces of 1/16"x3"x24" balsa from step 11a. The rear sheeting goes from F-5A to F-8.

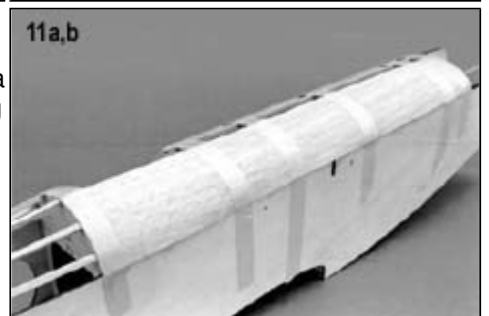

- c. After the glue has cured mark the cockpit opening using the template provided on the plan. Trim with a sharp knife and sand the edge with fine sandpaper.
- 12 Using the 1/4"x1"x15" balsa plank cut appropriate pieces for the cowl filler blocks and glue them in place on the front of the firewall and on top of the fuselage sides. Cut two small pieces of 1/2" triangular stock and glue them in the corners. After the glue has cured carve and sand the parts to shape.

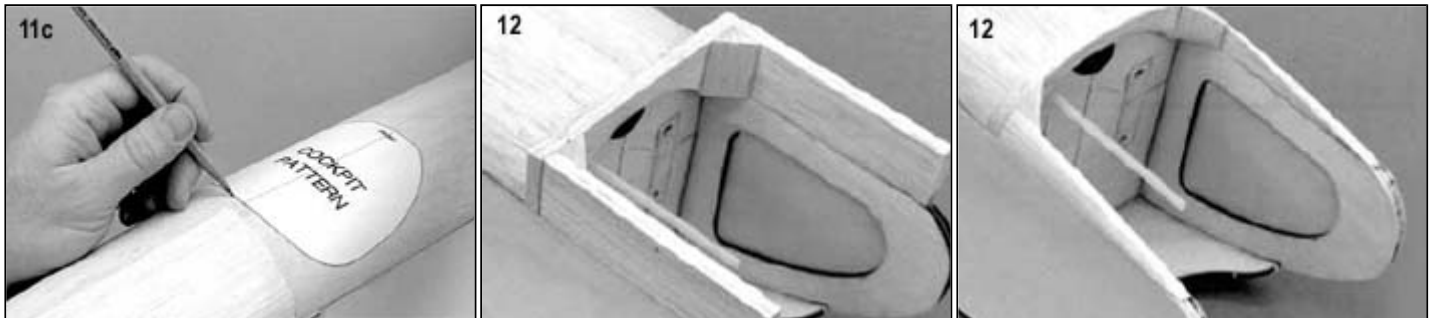

- 13 a. Referring to the section on plate two of the plans that shows the cabane plate assembly, glue the three cabane plates (P-6, P-7, and P-8) together with slow CA or epoxy. When the glue is cured run a 13/64" drill through both holes to make sure they line up and have no glue in the holes.
- b. Slide the two cabane struts into the slots in each end of the assembly, center the cabanes in the assembly and glue two 8-32 blind nuts in the correct side of the assembly.
- c. Center a 4" piece of 2" glass tape on the cabane plate, wrap the finished edges around the plate and glue in place. After the glue cures sand the assembly smooth and flat.



- 14 a. Centered over the holes in the fuselage side cut four 1/2"x1/2" clearance holes in the balsa sides of the front deck for the aluminum cabane mounts.

- 14 b. Making sure the slots in the cabane mounting blocks are clear of any debris, slide the cabane mount assembly in place in the four slots in the fuselage. Check the alignment of the holes in the aluminum cabane struts with the holes in the fuselage. All holes MUST line up to get the correct incidence when you assemble the Hog Bipe. Correct any problems of alignment now.

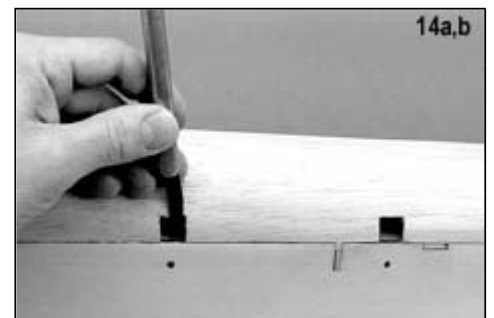

- 15 a. Locate the two pushrod outer sheaths (black) and thread them through the holes in the formers and the fuselage sides. The sheath should extend through the side of the fuselage at the rear far enough to be sanded off flush with the side. Note that one pushrod should exit the side in the top slot and one pushrod should exit the side in the lower slot. Glue the sheath securely at the rear fuselage side and at former F-7. The front of each sheath will be located after the servos are installed.



- b. Fill in any dings, dents or gaps with glue and/or filler. With a long sanding block sand the entire fuselage to remove any bumps and sharp edges. Try to achieve a smooth even surface all over the fuselage.

TOP WING CONSTRUCTION

NOTE: The top wing is built in one piece - be sure your building board is flat. CROOKED WINGS NEVER FLY RIGHT.

CAUTION:

There are a lot of pieces to be glued before the wing is removed from the building board, so place the pins carefully. After all the pieces are glued in place you must be able to get at the pins to remove them.

Builders Tip: For convenience you may want to cut the plan into four pieces;

1. top wing,
2. left bottom wing,
3. right bottom wing, and
4. miscellaneous details.

17. Pin the wing plan to the building board and cover the top wing section with waxed paper.
- 18 a. Pin down two 1/4"x1/2"x24" balsa sticks for the bottom spar. Any extra length should extend beyond the tip rib. Be sure and leave the gap in the middle. This is not a mistake.
 - b. Pin and glue in place all the W-2 and W-1T (center four) ribs on the plan. Use a triangle or a square block as a guide to keep the ribs square and vertical. Use the I-strut top mounts (P-2) as a spacer when gluing in the ribs on either side of P-2. Do not glue in either P-2 at this time. Make sure the jiggling tab on each rib is down against the building board.
 - c. Center the 5/16"x5/16"x48" shaped leading edge on the ribs and glue to all of the ribs.
 - d. True up one edge on each of two 1/16"x1-1/2"x48" balsa sheets and cut them down to 1" wide by trimming the second edge. Glue one piece to the bottom trailing edge of each rib. Use the glue sparingly so that you don't glue the partially cut jiggling tabs to each rib. Now glue the other piece to the top trailing edge of each rib.

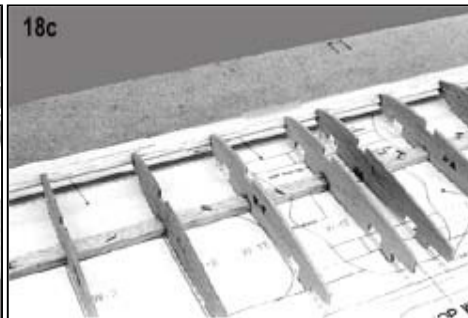
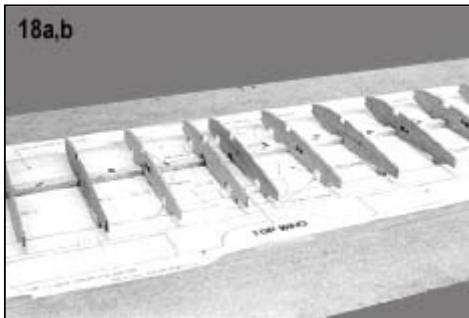

- 19 a. Finish cutting the die-cut slots in the W-1T ribs. Find the 1/8"x5/8"x11-11/16" plywood top wing brace (TWB), check the fit in the ribs and glue it in place on the bottom spar and to the ribs both front and rear.
 - b. Pin and glue the 1/4"x1/2"x48" balsa stick in the ribs as the top spar.
 - c. Glue all the pre-cut 1/16" balsa spar webbing in place as shown on the plans. Make sure that the web is glued to all the adjoining pieces. Here's another place that you don't want to be stingy with the glue.



- 20 a. True up one edge of a 1/16"x3"x48" balsa sheet. Pin the trimmed edge of the sheet to the shaped leading edge. Now glue this sheet to the shaped leading edge, wing ribs and top spar.
 - b. Using pieces of 1/16"x1/4" or 1/16"x1/2" balsa strip, cut and glue capstrips on the top of each wing rib as shown on the plan. Check the plan for the proper location of the two 1/16"x1/2" balsa capstrips.

c. When the glue has cured remove the wing from the building board.

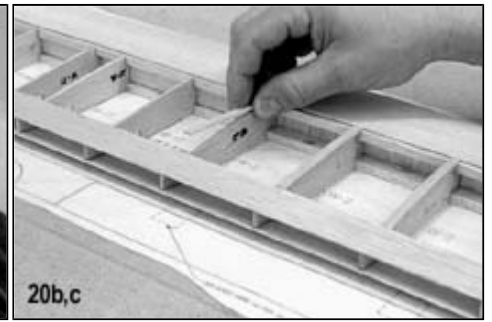

21 a. Cut the 1/4" triangular piece into eight 1" pieces. Referring to the photograph and the plans glue them to the sides of the two W-1T wing ribs. Find the two 1/8"x5/8"x6-5/8" Wing Mounting Plates (P-1) and check their fit in the wing. DO NOT GLUE IN NOW.

b. Find the two 1/2"x5/8"x1-1/8" maple top wing mount blocks (B-1) and position them on P-1 between the two innermost W-1T ribs and mark their location on the P-1. Remove the blocks and plates from the wing and glue the blocks to the plates. After the glue has cured use the hole in P-1 as a guide to drill a 3/16" hole through each maple block.

c. Insert the assembled P-1 and B-1 (2) into the wing with the blocks facing the top of the wing. Check with a triangle to make sure the two plates are straight and true with the 1/8" top wing brace. Glue the plates in place. Fill in the spaces in the W-1T ribs below the plate with scrap balsa and sand to the rib shape. Fill in between the two W-1T ribs and the leading edge with the wing leading edge block (B-4) and sand to shape.

d. When the glue has completely cured, remove the wing from the building board. Carefully remove all of the jig tabs on the ribs. Use a sanding block to smooth the outline of the rib to shape.

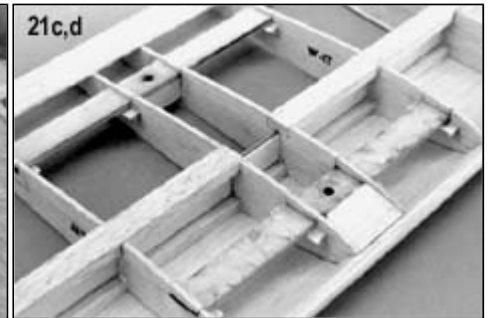
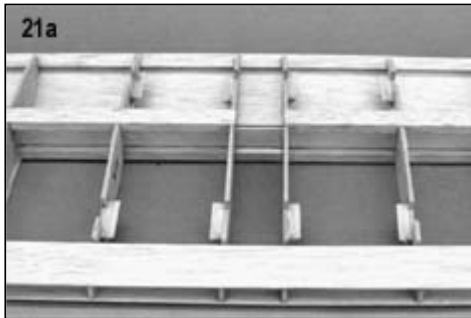

22 a. Pin the partially assembled wing back to the building board. Make sure the full length of the wing at the spar is down against the building board. Using a 1/4"x1/2"x36" balsa stick as a jig/spacer pin the trailing edge to the building board. Be very careful that everything is straight and flat, this is the step that "sets" the shape of the wing.

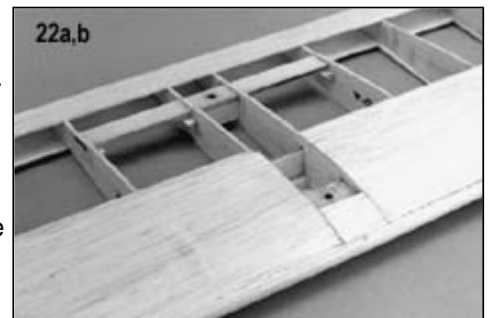

b. True up one edge of each of two 1/16"x3"x24" balsa sheets. Pin the trimmed edge of the sheet to the shaped leading edge, one sheet to each side of the wing. Now glue these sheets to the leading edge, ribs, spar and innermost W1-T rib.

23 a. Install a 4-40 blind mounting nut in each of the I-strut top mounts (P-2) with a small hammer. Be sure you make a right and a left P-2 assembly. Spread epoxy glue over the blind nuts to hold them in place. Be careful not to get any glue in the threads of the blind nuts.

b. Using epoxy or medium CA glue P-2 between the two closeset ribs on each panel of the wing. The blind nuts should be on the inside surface of the P-2 when you are done. The top of P-2 must be pushed firmly against the capstrips on the top of the ribs. This step is critical for the alignment of the interplane struts later on. Refer to the cross-section of the I-strut on plan sheet 2 of 2.

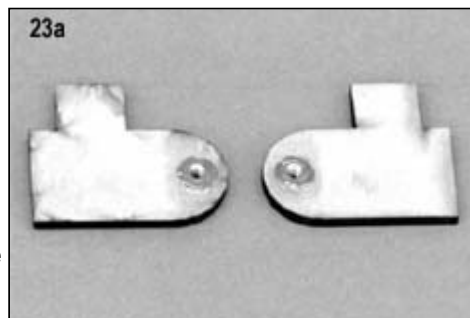

- 24 a. Using pieces of 1/16"x1/4" balsa strip, cut and glue capstrips on the bottom of the wing as indicated on the plans. Note that the capstrip at the I-strut mount (P-2) is cut from 1/16"x1/2" balsa strip. Notch one end of the capstrip to fit around P-2 and glue in place. When dry, remove the building board.
- b. Using 1/16"x2"x36" balsa sheets, sheet the top and bottom of the center section as shown on the plans.
- c. When the sheeting glue has cured drill two 3/16" holes in the center section by drilling from the bottom up through the mounting plates (P-1). Enlarge both holes in the balsa sheeting only to 7/16", keeping the holes centered on the holes in the mounting plate. The easiest way to do this is to use a 7/16" diameter piece of sharpened brass tubing.

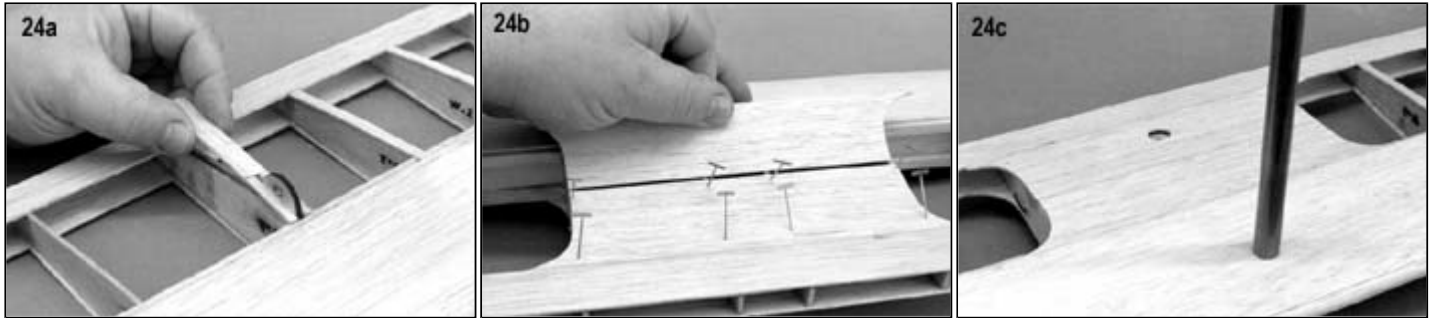

- 25 a. Using a long flat sanding block sand the trailing edge sheeting flush with the trailing edge of the ribs.
- b. Glue and pin or tape the 1/4"x3/4"x48" balsa stick to the trailing edge of the ribs.
- c. When the glue has cured carve and sand the trailing edge to shape. Match the taper of the trailing edge stick to the shape of the ribs and maintain a sharp corner at the trailing edge.
- d. Sand the sticks and sheeting at each end flush with the end rib and perpendicular to the spar.



- 26 a. Find the four lite-ply wingtips and the four lite-ply wingtip supports. Assemble a wingtip support to each of the wingtips and glue in place. When dry sand wingtip support flush with the wingtip on both sides. Set two of the assemblies aside for later use.

- b. Center one of the wingtips assemblies on an end rib. Make sure the leading edge of the wingtip matches the leading edge of the wing and is centered on the leading edge. Tack glue in place. Center the trailing edge of the wingtip on the trailing edge of the wing and tack glue. Using a triangle as a guide finish gluing the wingtip to the tip rib.

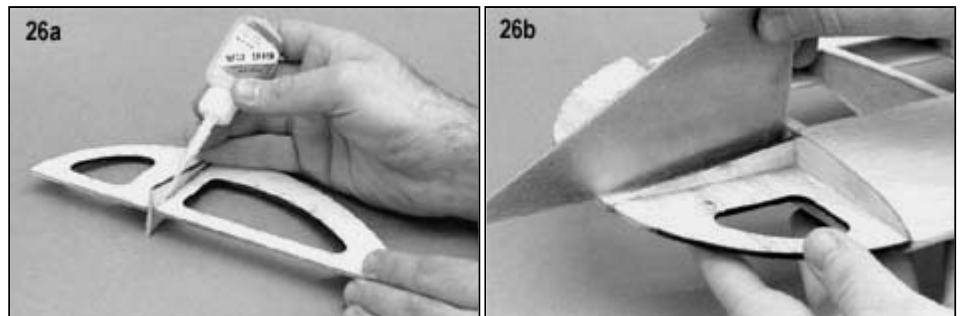

- c. Glue a wing tip rib (WTR) on the top and bottom of the wingtip, spacing the rib so that the 1/16" sheet applied in the next step will be flush with the leading edge sheet of the wing.

- d. Cut four pieces of 1/16"x4" balsa sheet to fit on the top and bottom of the wingtip. Shape the wingtip sheet so that it fits neatly to the leading edge sheet when the wingtip sheet is wrapped around the wingtip. Glue the top and bottom wingtip sheet in place. Sand the balsa sheeting flush with the plywood wingtip.
- e. Find four of the wingtip blocks (WTB), glue two of them in place at the trailing edge of the wingtip.

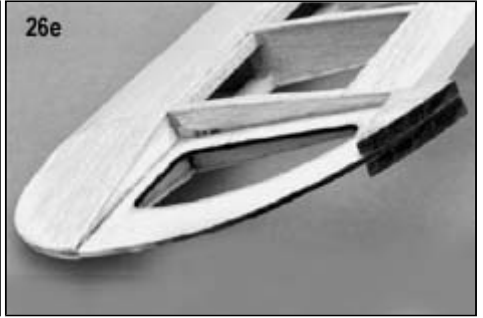
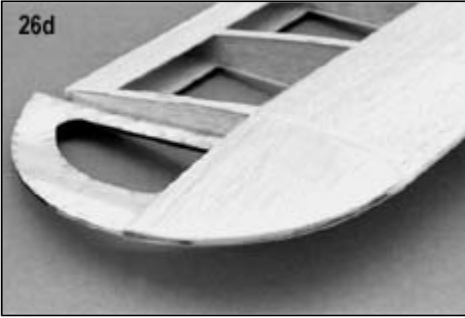
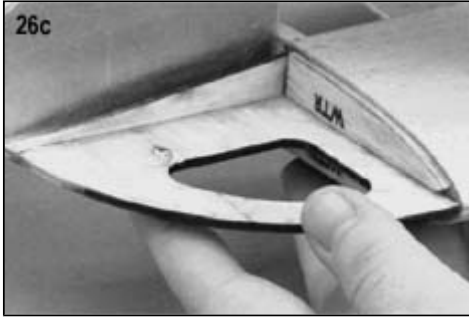

27 Repeat steps 26b. through 26e. for the other wingtip.

28 a. From the 1/2"x1-1/2" balsa trailing edge stock cut a length to match the piece shown at the center of the trailing edge of the top wing. Cut and sand the radius using the pattern on the plan. Draw a center line on the trailing edge piece and the wing. Match the two center lines and glue the center trailing edge piece to the wing.

b. Cut two ailerons to length from the 1/2"x1-1/2" aileron stock. Temporarily tape the ailerons to the wing, carve and sand the ailerons to match the wingtips.

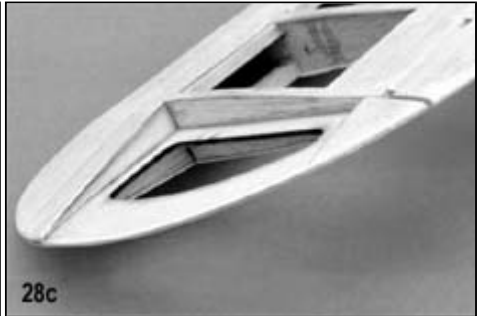
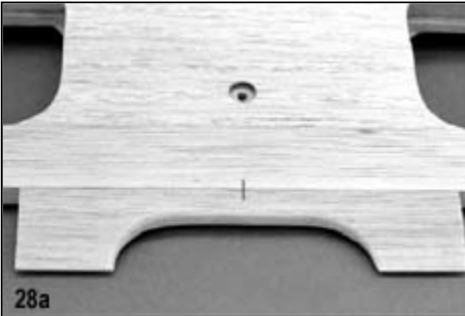

c. Using a short sanding block fair all of the lines of the wingtip into the wing. Round off all of the corners to a pleasing shape.

29 Fill in any dings, dents or gaps with glue and/or filler. With a long sanding block sand the entire wing to remove any bumps and sharp edges. Try to achieve a smooth even surface all over the wing.

BOTTOM WING CONSTRUCTION

NOTE: The bottom wing is built in two pieces. It is easier to build one bottom panel at a time - it's much easier to set the center rib angle with nothing in the way. Be sure your building board is flat. CROOKED WINGS NEVER FLY RIGHT.

CAUTION: There are a lot of pieces to be glued before the wing is removed from the building board, so place the pins carefully. After all the pieces are glued in place you must be able to get at the pins to remove them.

30. Pin the right bottom wing plan section to the building board and cover with waxed paper.

31 a. Pin down a 1/4"x1/2"x24" balsa stick for the bottom spar. Any extra length should extend beyond the tip rib.

b. Pin and glue in place all the W-2 balsa ribs on the plan. Use a triangle or a square block as a guide to keep the ribs square and vertical. Use the I-strut bottom mount (P-3) as a spacer guide when gluing in the ribs on either side of P-3. Do not glue in P-3 at this time. Make sure the jiggling tab on each rib is down against the building board.



- c. Using the dihedral gauge glue rib W-1 to the bottom spar. The top of the rib should slant towards the wingtip. The angle on the dihedral gauge is 3 degrees.
- d. Pin and glue a 1/4"x1/2"x24" balsa stick in the ribs as the top spar. Check the angle of rib W-1 with the dihedral gauge before gluing rib W-1 to the spar

32 a. Cut one 48" shaped leading edge in half. Center one 24" shaped leading edge on the ribs and glue to all of the ribs.

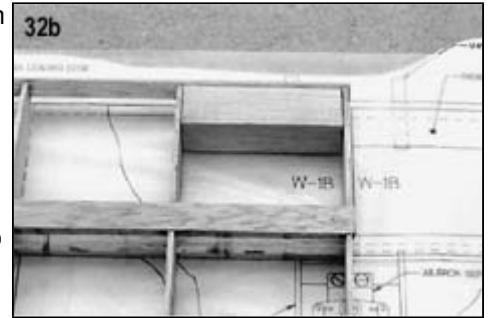

- b. Find one 1"x1"x3" balsa wing dowel block (B-5) and sand to fit between ribs W-1B and W-2. Fitting will require a small angle on one end to match the dihedral angle of rib W-1B and a bit of shortening (all of the pieces are cut oversize to allow for some variation). Glue block B-5 in place behind the leading edge and between ribs W-2 and W-1B. When the glue cures sand the profile of the block to match the wing ribs.

33 a. True up one edge on each of two 1/16"x1-1/2"x24" balsa sheets and cut them down to 1" wide by trimming the second edge. Glue one piece to the bottom trailing edge of each rib. Use the glue sparingly so that you don't glue the partially cut jiggling tabs to each rib. Now glue the other piece to the top trailing edge of each rib.

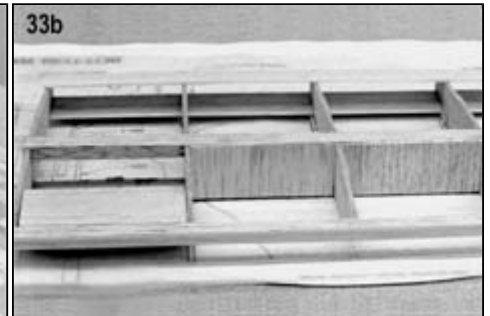

- b. Glue all the pre-cut 1/16" balsa spar webbing in place as shown on the plans. Make sure that the web is glued to all the adjoining pieces. Here's another place that you don't want to be stingy with the glue.

34 a. True up one edge of a 1/16"x3"x24" balsa sheet. Pin the trimmed edge of the sheet to the shaped leading edge. Now glue the sheet to the leading edge, wing ribs, and top spar.



- b. Using pieces of 1/16"x1/4" balsa strip, cut and glue capstrips on the top of each wing rib as shown on the plan. Note that the capstrip at P-3 is cut from 1/16"x1/2" balsa strip. Do not glue this capstrip on now.

- c. When the glue has completely cured, remove the wing from the building board. Carefully remove all of the jig tabs on the ribs. Use a sanding block to smooth the outline of the rib to shape.

35 a. Pin the partially assembled wing back to the building board upside down. Make sure the full length of the wing at the spar is down against the building board. Using a 1/4"x1/2"x36" balsa stick as a jig/spacer pin the trailing edge to the building board. Be very careful that everything is straight and flat, this is the step that "sets" the shape of the wing.

- b. True up one edge of a 1/16"x3"x24" balsa sheets. Pin the trimmed edge of the sheet to the shaped leading edge. Glue this sheet to the leading edge, ribs, spar and innermost W1-B rib.

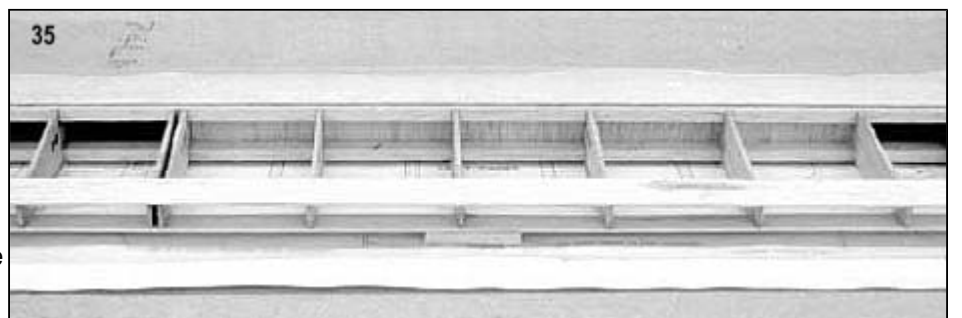

- c. Using pieces of 1/16"x1/4" balsa strip, cut and glue capstrips on the bottom of the wing as indicated on the plans. Note that the capstrip at the I-strut mount (P-3) is cut from 1/16"x1/2" balsa strip.

36 a. Using a long flat sanding block sand the trailing edge sheeting flush with the trailing edge of the ribs.



b. Cut the 1/4"x3/4"x48" balsa in half, glue and pin or tape the stick to the trailing edge and the ribs.

c. When the glue has cured remove the wing from the building board.

d. Carve and sand the trailing edge to shape. Match the taper of the trailing edge stick to the shape of the ribs and maintain a sharp corner at the trailing edge.

e. Sand the sticks and sheeting at each end flush with the end rib and perpendicular to the spar.

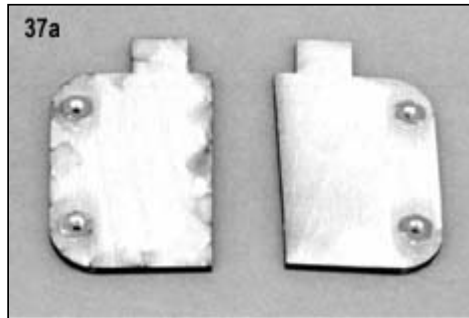

37 a. Install a 4-40 blind mounting nut in each of the I-strut bottom mounts (P-3) with a small hammer. Be sure you make a right and a left P-3 assembly. Spread epoxy glue over the blind nuts to hold them in place. Be careful not to get any glue in the threads of the blind nuts.

b. Using epoxy or medium CA, glue the P-3 between the two close-set ribs on each panel of the wing. The blind nuts should be on the inside surface of the P-3 when you are done. The bottom of P-3 must be flush with the bottom of the ribs. This step is critical for the alignment of the interplane struts later. Refer to the cross section of the I-strut on plan sheet 2 of 2.

c. Cut a capstrip from 1/16"x1/2" balsa strip to fit at P-3. Notch one end of the capstrip to fit around P-3 and glue in place.

38 a. Center one of the wingtip assemblies on an end rib. Make sure the leading edge of the wingtip matches the leading edge of the wing and is centered on the leading edge. Tack glue in place. Center the trailing edge of the wingtip on the trailing edge of the wing and tack glue. Using a triangle as a guide finish gluing the wingtip to the tip rib.

b. Glue a wing tip rib (WTR) on the top and bottom of the wingtip, spacing the rib so that the 1/16" sheet applied in the next step will be flush with the leading edge sheet of the wing.

c. Cut four pieces of 1/16"x4" balsa sheet to fit on the top and bottom of the wingtip. Shape the wingtip sheet so that it fits neatly to the leading edge sheet when the wingtip sheet is wrapped around the wingtip. Glue the top and bottom wingtip sheet in place. Sand the balsa sheeting flush with the plywood wingtip.

d. Find two of the wingtip blocks (WTB), glue them in place at the trailing edge of the wingtip.

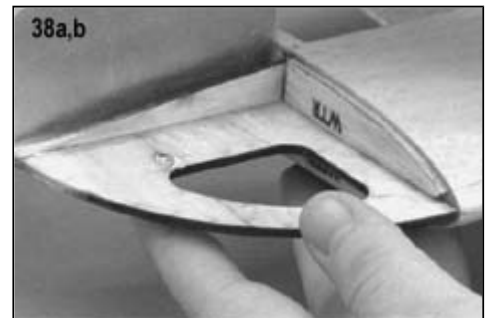

39 a. Glue sub ribs SBR-1 and SBR-2 together. Place this subassembly against the spars and root rib W1-B and glue in place. When the glue has cured use a small sanding block to make sure SBR-1 and SBR-2 are flush with the wing ribs and spar.

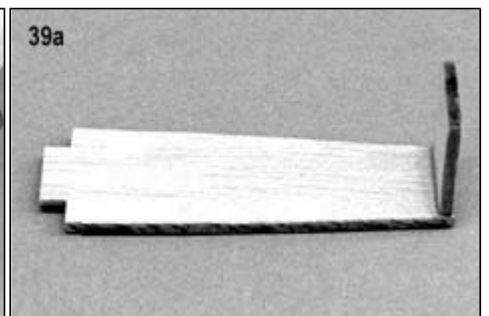
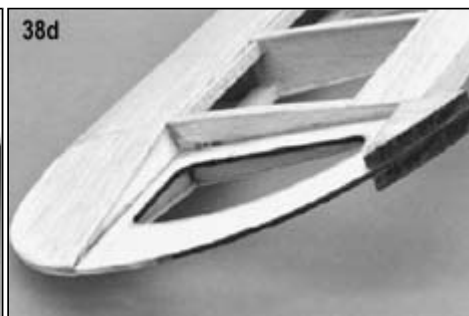
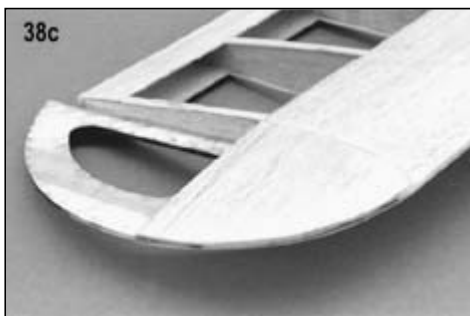

b. Now is the time to check all of the glue joints and to add glue where necessary.

40. Pin the left bottom wing plan section to the building board and cover with waxed paper.

41. Build the left wing panel by repeating steps 31a through 39b.

42 a. Carefully block sand the two wing panels until all joints are smooth and even. Use a large sanding block to avoid sanding any one area to thin.

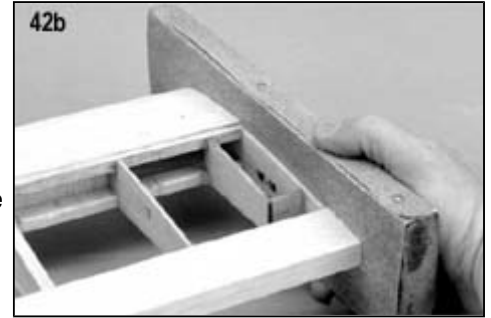

b. Block sand the wing root of both panels until the leading edge, spars, trailing edge and all sheeting are flush with the pre-angled W1-B ribs.

43 a. Finish cutting the diecut slot in the two W-1B wing ribs for the dihedral brace.

b. Trial fit the dihedral brace in both bottom wing panels. It is critical that both panels slide all the way on the dihedral brace and that the two ends of the panels meet without gaps all around the center joint.

c. Use slow epoxy glue to hold the two bottom wing panels together. First work glue into the slots using a dowel or a wire to insure that the dihedral brace is locked to the top and bottom spars for the full length of the brace. Coat the root of both panels and the dihedral brace with a light coat of epoxy and slide the panels onto the dihedral brace. Carefully line up the leading and trailing edges of both panels and pin to prevent shifting or misalignment. Wipe off any excess glue, block up the panels in a stable position and let the glue cure.

44 a. Using 1/16"x2"x36" balsa sheets, sheet the bottom of the center section as shown on the plans. Let dry.

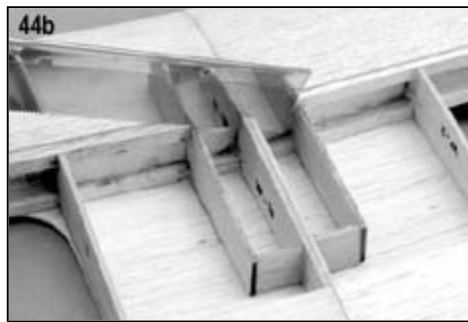

b. Cut out the section of the two W-1B ribs between SBR-2 and the main spar where the servo will mount.

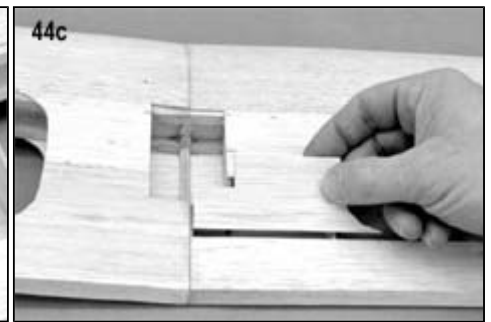

c. Using 1/16"x2"x36" balsa sheets, sheet the top of the center section as shown on the plans. Let dry.

45 a. Using the plan as a guide mark the clearance notches for the arm of the torque rod on the trailing edge of the wing. Cut the notch to clear the torque rod on both sides of the center joint.

b. Glue the aileron torque rod assemblies in the two 1/2"x1 1/2"x2-7/16" pre-shaped balsa trailing edge. Be especially careful not to get any glue in the torque rod tube.

c. Glue the trailing edge piece and torque rod assemblies to the trailing edge of the wing. Again, be very careful not to get any glue in the torque rod.

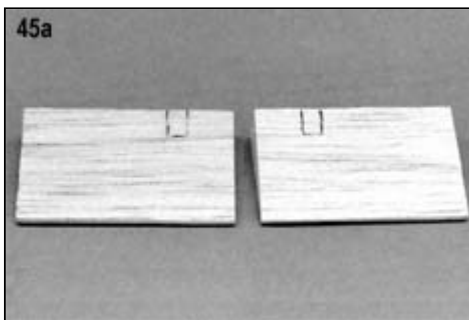

BUILDERS TIP:

3M 77 will make the gluing of glass tape much easier. Just "fog" a light coat of cement on one side of the tape. This will help hold the tape in place without interfering with the holding power of the CA.

46 a. Cut a strip of 1" glass tape long enough to wrap from one side of the servo opening around the wing to the other side of the servo opening.

b. Anchor one end of the glass tape in the servo opening with masking tape. Stretch the tape over the trailing edge of the wing, across the bottom, around the leading edge and back into the servo opening. Anchor this end of the glass tape with another piece of masking tape.

c. Using thin CA start at one side of the servo opening and flow glue into the tape with a side-to-side motion. As the glass tape turns clear move on around the center seam until the complete length of the tape is glued. Remove any extra glue with a clean rag.
 Try not to flood the tape with excess glue as it will cure quickly and cause bumps and snags in the glass tape, which would result in more sanding.

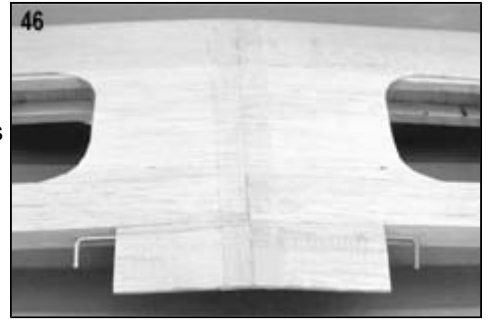

d. Sand the center seam smooth, being careful not to sand into the glass tape too much - just remove the rough spots and cut the peaks off the weave of the tape.

47. Glue the 1/32" plywood wing bolt plates (P-9) in place on the bottom of the wing.

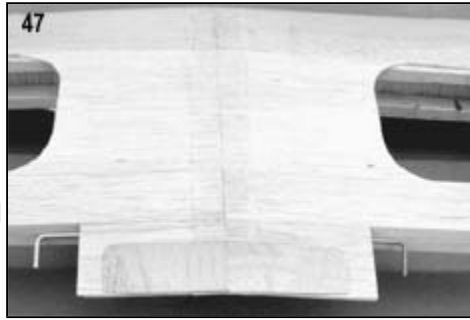

48 a. Cut two ailerons to length from the 1/2"x1 1/2" aileron stock. Temporarily tape the ailerons to the wing, carve and sand the ailerons to match the wingtips.

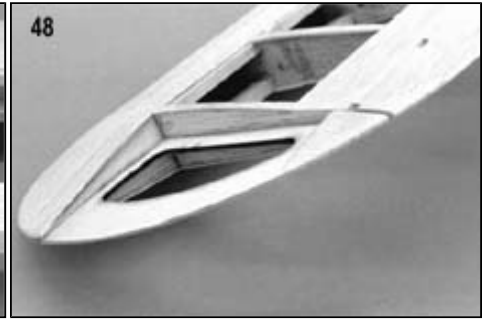

b. Using a short sanding block fair all of the lines of the wingtip into the wing. Round off all of the corners to a pleasing shape.

49 Fill in any dings, dents or gaps with glue and/or filler. With a long sanding block sand the entire wing to remove any bumps and sharp edges. Try to achieve a smooth even surface all over the wing.
 NOTE: You must have a completed bottom wing to proceed with this phase of the construction.

MOUNTING THE BOTTOM WING TO THE FUSELAGE

50 a. Careful alignment is particularly important with biplanes, so take your time and be very accurate when making alignment marks and when taking measurements. Mark the center of the leading and trailing edge of the bottom wing on the bottom of the wing. Also mark the center of the fuselage at the front and rear of the wing saddle.

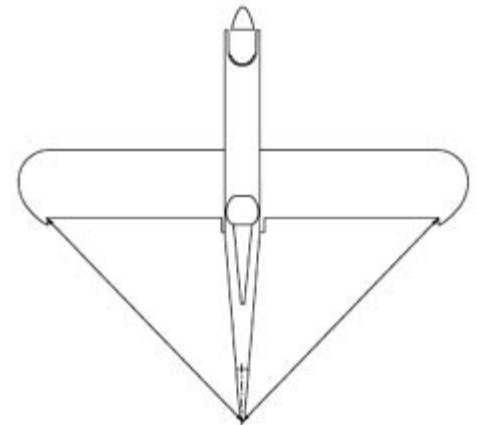

b. Place the bottom wing on the fuselage and check the fit. If everything was properly built the wing should fit into the opening without any gaps. If the wing does not fit properly, now is the time to sand off any bumps or to fill any hollows to match the contour of the wing.

DO NOT CHANGE THE INCIDENCE OF THE WING
 - this is critical to the flying characteristics of the airplane.

b. Tape the wing to the fuselage and take measurements from the outer end of the aileron cutouts to the tail of the fuselage. Both measurements should be the same. If not, rotate the wing, keeping the leading edge in place, until both measurements are identical. Remark the trailing edge to reflect the correct position. Remove the wing from the fuselage.

51 a. Generate a shallow point on one end on each of the two 1/4" diameter x1 1/2" dowels, keeping the point centered on the end of the dowel. Push the dowels into the holes in F-3 until only the points are sticking out. With the wing lined up on the marks made earlier slide the wing into the opening until it is fully seated. When you remove the wing there should be two small indentations in the leading edge. Make a cross mark at each indentation with lines at least 3/8" long.



- b. Drill an 1/8" hole in the leading edge of the wing at each indentation. Check the location of the holes in reference with the cross marks. If necessary shift the holes to align with the cross marks by drilling a slightly larger hole, hold pressure on the drill to "walk" the hole into alignment with the cross marks. Enlarge the holes to 1/4" and drill clear through the bottom leading edge block (B-5). Keep the drill perpendicular to the leading edge and parallel to the centerline of the airfoil.
- c. Remove the wing dowels from F-3, place a piece of waxed paper over the face of F-3 and reinsert the dowels 1/2" through the waxed paper leaving 1" exposed.
- d. Trial fit the wing onto the dowels and into the wing opening. The wing should seat firmly in place without gaps, but should not be so tight as to mark the balsa sheeting. If necessary, carefully enlarge the holes in the wing leading edge until the wing seats properly.
- e. When satisfied with the fit of the wing to the wing dowels and the fuselage opening, coat the inside of the holes in the leading edge of the wing with epoxy and slide the wing onto the wing dowels. Align the marks on the wing with those on the fuselage, tape or pin the wing securely and let the epoxy cure. Remove the wing and fill any gaps around the dowels with more epoxy.

52 a. Shape the basswood Bottom Wing Mounts (B-2) to fit the notch in the fuselage doublers. The side that is in contact with the fuselage side must be beveled slightly to match the dihedral angle of the bottom wing. Before gluing in place each B-2 needs to fit snugly against the fuselage side, Former F-5 and the top of the bottom wing. Glue both B-2 in place after you are satisfied with their fit.

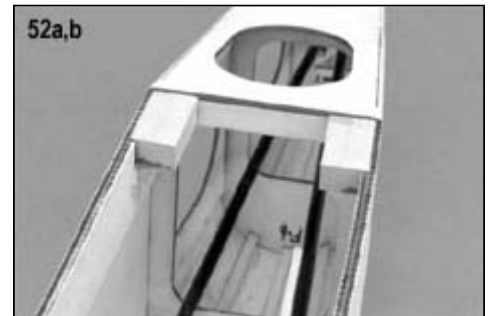

b. Cut two 1-1/2" lengths of 1/2" balsa triangular stock to brace both B-2. Glue a triangular brace between the top of each B-2 and the fuselage doubler - don't be stingy with the glue!

c. On the bottom of the bottom wing mark the location of the two holes for the wing bolts on the plywood reinforcing plates. Visually confirm that a hole drilled at this location will pass through the approximate center of each B-2.



d. Seat the wing in the fuselage opening and tape securely in place - check the matchup of the alignment marks. With a #7 or 13/64" drill bit, drill two holes through the bottom wing and B-2. Make every effort to keep the holes perpendicular to the bottom of the wing so that the heads of the wing bolts will seat flat on the bottom of the wing.

53 a. Remove the wing and soak the holes in both B-2 with CA. AFTER the CA has cured tap both holes 1/4 - 20. Apply a few drops of CA to each hole to strengthen the threads. After the CA has cured retap the hole to cleanup the threads.

b. Enlarge the holes in the wing to 1/4" to accept the wing bolts. Soak the holes with CA and AFTER the CA has cured redrill the holes for a close fitting and long wearing wing bolt hole.

STABILIZER AND ELEVATOR

54 a. Pin the stabilizer and elevator plan to the building board and cover with waxed paper.

b. Pin in place and glue the laser cut parts S-1, S-2, and S-3.

c. Cut to length and glue in place the 1/4"x1/2" balsa leading and trailing edges.

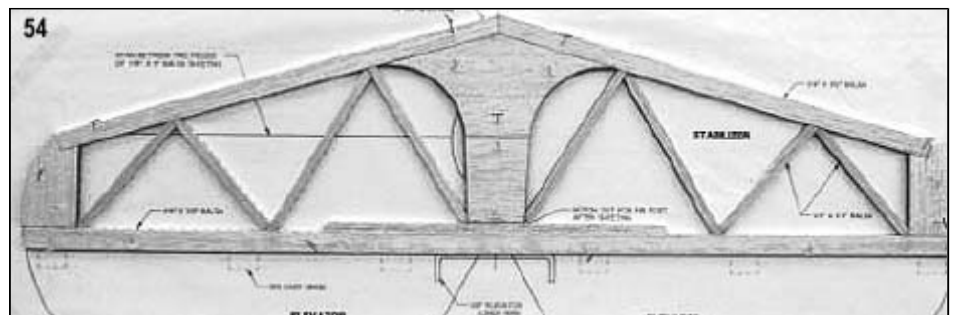

d. Cut and glue in place the 1/4"x1/4" balsa strip ribs.

e. When the glued has cured remove the stabilizer frame from the plan, reglue all the joints and then sand both sides flat and smooth with a long sanding block.

55 a. Trim one edge of each of four sheets of 1/16"x3"x30" balsa sheet straight and square. Glue the trued edges of two sheets together to make the bottom stabilizer sheet. Glue the trued edges of two more sheets together to make the top stabilizer sheet. Trim a corner from each assembled sheet to finish out the center of each sheet. Sand both sides of the assembled sheets to remove any extra glue and to generate a smooth surface - do it now as it's nearly impossible to sand the sheets when they are over an open framework.

b. Using Slow CA or SIG Bond glue the top and bottom sheets to the stabilizer frame. With Slow CA, if you're quick, you can do both sides at once, but it's safer to do one side at a time. With SIG Bond you have plenty of time to glue both sides. Weight or pin the assembly flat until the glue cures.

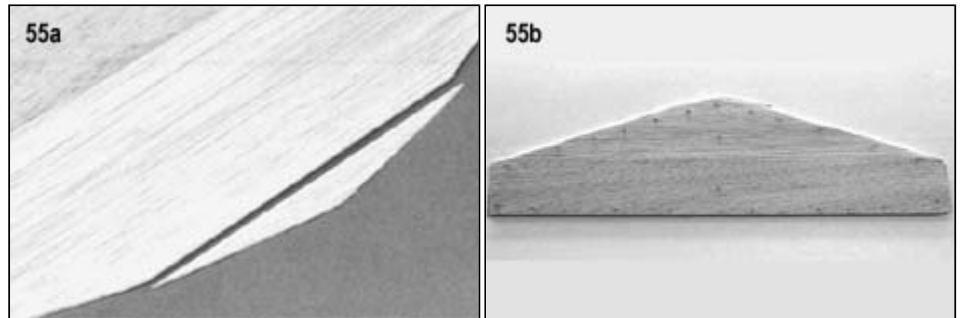

c. Sand the top and bottom sheeting flush with the frame all around. Sand a flat on the front of the stabilizer to match the one on the plan.

d. With a soft pencil or felt tip marker place a centerline from the trailing edge around the tip, along the leading edge and back around the other tip to the trailing edge. Using the centerline as a guide round off the tips and the leading edge with a sandpaper block.

LEAVE THE TRAILING EDGE SQUARE.

56 a. Two 3/8"x3"x12" tapered balsa sheets are provided for making the elevators. Cut one of the elevator patterns from the plans and trace the outline on both pieces of tapered stock. Cut the elevators to this shape. Notice that one side of the tapered stock is rougher than the other. Plan your cutting of the right and left hand elevators so the smooth side is used as the top on both elevators.

b. With a solvent wipe the oil off the elevator joiner wire. Using the plans and the 1/8" wire elevator joiner mark the elevators where the wire joiner will be inserted. Drill an 1/8" hole in each elevator half at the mark. Groove the leading edge of each elevator half so the wire joiner is flush with the leading edge of the elevator halves.

c. Sand the joiner wire for a better glue bond. Coat the joiner wire with Qwik-Set epoxy, work some epoxy into the holes and grooves in the elevator halves, insert the joiner wire into the elevator halves and lay the assembly against a straight edge to keep the three pieces in proper alignment.

d. When the glue has cured block sand the rough side of the elevators to match the thickness of the stabilizer. Do not sand the elevators thinner than the stabilizer. Tape the elevators to the stabilizer and blend the shape of the tips together.

e. Cut two 2" pieces of 1" glass tape, wrap them around the leading edge of the elevators over the joiner, wire and glue in place with thin CA. Sand smooth and blend the edges of the glass tape into the elevators. Don't sand so much, that you defeat the purpose of the glass tape.

f. Mark a centerline around the tip of each elevator half. Using the centerline as a guide taper the trailing edge of the elevators to a constant thickness. Round off all of the edges of the elevator assembly.

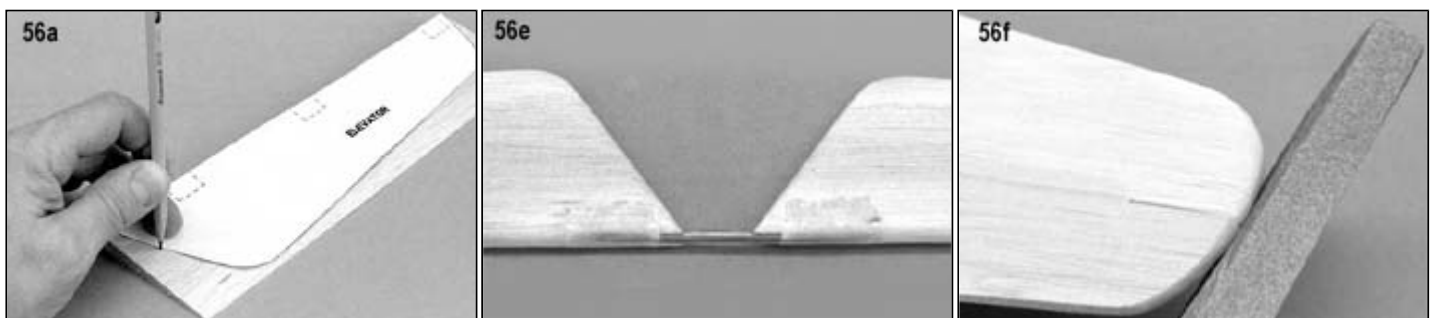

FIN AND RUDDER

- 57 a. Pin the fin and rudder plan to the building board and cover with waxed paper.
- b. Pin in place and glue the laser cut parts F-1, F-2, and F-3.
- c. Cut and glue the 1/4"x1/2" balsa fin post on the back of the assembled fin parts.
- d. Remove the glued parts from the plan, reglue all the joints and then sand the assembled fin flat and smooth.
- e. With a soft pencil or felt tip marker place a centerline from the trailing edge around the tip, along the leading edge and out to the end of the dorsal fin. Using the centerline as a guide round off the tip and the leading edge with a sandpaper block. LEAVE THE TRAILING EDGE AND BOTTOM OF THE FIN SQUARE.

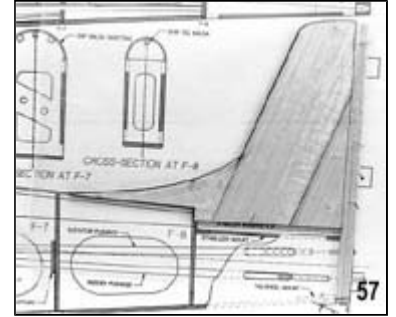

- 58 a. A piece of 1/4"x3"x12" tapered balsa sheet is provided for making the rudder. Cut the rudder pattern from the plans and trace the outline on the piece of tapered stock. Cut the rudder to this shape.
- NOTE: Cut the notch required to clear the elevator joiner wire.

- b. Notice that one side of the tapered stock is rougher than the other. Block sand the rough side of the rudder until the rudder and fin are the same thickness. Tape the rudder to the fin and blend the shape of the tips together.

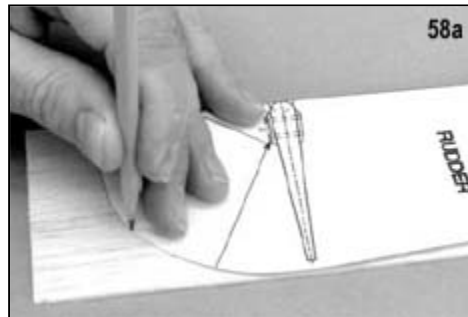

- c. Mark a centerline around the tip of the rudder. Using the centerline as a guide taper the trailing edge of the rudder to a constant thickness. Round off all of the edges of the rudder.

MOUNTING THE TAIL SURFACES

- 59 a. Mark a centerline on the top of the stabilizer, making sure that the centerline is perpendicular to the trailing edge of the stabilizer. Pin the stabilizer to the fuselage, mount the lower wing to the fuselage and measure from each tip of the stabilizer to the trailing edge of the lower wing. Both measurements should be the same. If there is any difference slide the stabilizer right or left until the measurements are identical.

KEEP THE TRAILING EDGE OF THE STABILIZER PERPENDICULAR TO THE CENTERLINE OF THE FUSELAGE.

Place reference marks on the stabilizer and fuselage so you can glue the stabilizer in the correct place in a later step.

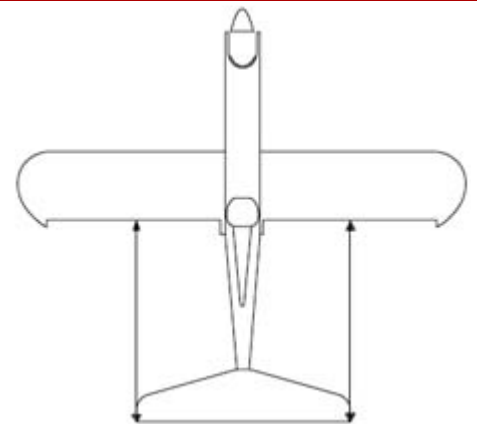

- b. Mark the inside edges of the fuselage sides on the trailing edge of the stabilizer as a reference for cutting the notch for the fin post. Remove the stabilizer from the fuselage and cut a 1/4" wide x 1/2" deep notch in the trailing edge of the stabilizer.
- c. Mount the bottom wing on the fuselage, pin the stabilizer on the fuselage, making sure the alignment marks are properly located, and sight from the rear of the fuselage forward. The tips of the stabilizer should meet the top of the wing at the same time. If this does not happen, sand the stabilizer platform to bring the stabilizer and wing into alignment. Sand on one side only - DO NOT CHANGE THE INCIDENCE by sanding on the front or rear of the stabilizer platform.

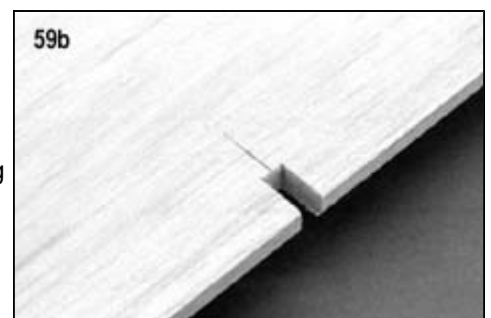

- 60 a. Temporarily pin the stabilizer and fin to the fuselage while maintaining the correct alignment of the fin and stabilizer to the fuselage. Place the 5/8"x5/8"x6" balsa filler blocks on either side of the fin. Mark the profile of former F-8 on the front of both filler blocks.

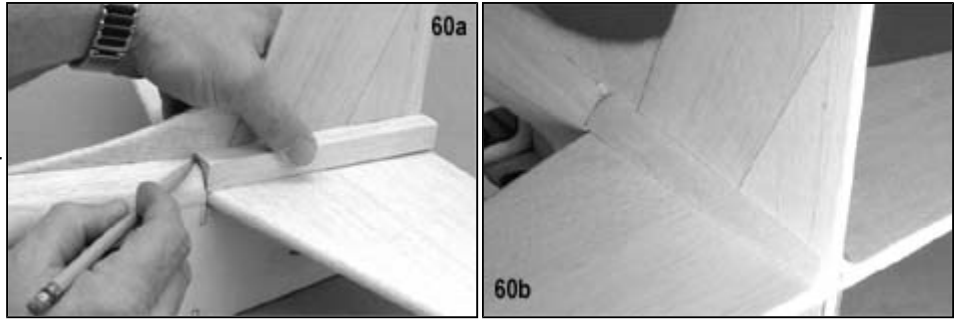

- b. Carve and sand each block to match the traced shape of F-8 and the tapered shape shown on the plans. Check the fit and shape of both parts with the assembled fuselage, stabilizer and fin. Try for a smooth and even blend from F-8 to the aft end of each block.

FINAL ASSEMBLY

Now is the time to cover the Hog-Bipe.

61. If you are going to cover and paint your Hog-Bipe, you need to go to step 73 and complete the headrest and wheelpants in steps 73a and 74b.
- 62 a. Glue the stabilizer to the fuselage. This is the place where care and precision really pays off. If all the elements of an airframe are not straight and true the completed airplane will never fly like it should.
- b. Glue the fin to the stabilizer and the fuselage. Before the glue sets make sure the fin is perpendicular to the stabilizer and straight on the centerline of the fuselage. Don't be shy, make sure the stabilizer and fin are well glued.
- c. Glue the two balsa filler blocks in place.

Control Surface Hinging

SIG EASY HINGES are probably the easiest-to-use hinges ever developed.

1. Begin by carefully cutting a very shallow slit at the hinge location using a fresh, sharp #11 blade in your modeling knife. This first slit should be very shallow so you can better control the direction of the knife. It's main purpose is to establish your hinge slot in the right place, so concentrate on staying on the hinge line and don't try to cut too deep.
NOTE: Make the slit slightly wider than the actual hinge.
2. Now make 3 or 4 more cuts in the exact same line, going slightly deeper each time. As you make these additional cuts, concentrate on staying in the slit and keeping the blade headed straight into the center of the wood so that it won't come out the side of the part. You will find that as the blade gets deeper into the wood, it will become harder to move it along the slot. Try "wiggling" the knife handle in the slot to make it cut, instead of trying to "slice" the blade along in one continuous motion. Continue making additional cuts until the slot is approximately 1/2" deep.
CAUTION: You must use extreme care to avoid cutting yourself while cutting the hinge slots. If the balsa wood breaks while you are pushing on the knife, the blade could go into your hand before you can stop it. A good precaution is to wear a leather glove on the hand that is holding the model part while you are cutting the slots.
3. After all the slots have been cut, insert a single Easy Hinge halfway into each hinge slot in the stabilizer. If the hinge is difficult to push in, re-insert the knife and move it back and forth in the slot a few more times and then try again. **DO NOT GLUE THE HINGES IN AT THIS TIME!**
4. Now carefully slide the elevator onto the exposed half of the Easy Hinges. You will find it easiest to slide the part onto the hinges at angle, one hinge at a time, instead of trying to push it straight onto all the hinges at once. Don't be overly concerned if the hinges don't end up perfectly straight or centered in the slots - they do not have a center line. **ONCE AGAIN, DO NOT GLUE THE HINGES IN AT THIS TIME!**
5. To set the proper amount of gap between the model parts, simply deflect the control surface to the maximum amount of travel needed. This will automatically set the proper hinge gap! Keep in mind that for best control response the gap should be kept as small as possible, but big enough to allow full movement of the control surface.

6. Place three or four drops of Thin CA glue directly onto the Easy Hinge in the gap. You will notice that the glue is quickly wicked into the slot as it penetrates both the wood and the hinge. Turn the part over and glue the other side of the Easy Hinge. Continue this process until you have glued both sides of all the Easy Hinges! Keep a rag handy to wipe off any excess Thin CA. (CA glue residue can be cleaned from most iron-on plastic covering materials with CA Debonder).

VERY IMPORTANT: Make only one application of glue to each side of an Easy Hinge! If you apply additional glue to the hinge after the first application of glue is already dry, the second application of glue will merely puddle in the hinge gap and make the hinge too stiff to operate properly. The excess glue could also weaken the hinge! When properly glued, the portion of the Easy Hinge that you can see in the hinge gap should have a dry appearance, not wet. A dry appearance indicates that almost all of the glue has properly soaked into the hinge slot. A wet appearance indicates that excess glue is puddled in the hinge gap. Three to four good size drops of Thin CA should be about the right amount.
NEVER USE CA ACCELERATOR ON EASY HINGES!

7. Let the glue dry a minimum of 3-5 minutes before flexing the hinges. At first you might notice a little stiffness in the joint. This will go away after the hinges have been flexed back and forth a couple dozen times.
63. The elevator must be hinged before the rudder - if you reverse this order you will have to cut off the rudder to hinge the elevator!!
64. a. Two #2 flat washers are included in the kit to act as retainers for the tailwheel. Of course, you can use 1/16" wheel collars (not included in kit), but the soldered washers give a more "finished" look.
 - b. Wipe the oil off the tailwheel wire with solvent and sand the area where the wire is in the rudder. Insert the tailwheel wire into the tailwheel bracket and using the plans as a guide, bend over the end of the tailwheel wire.
 - c. Mark and drill the holes in the bottom of the fuselage for the tailwheel bracket. Mount the tailwheel bracket with two #4 x1/2" sheet metal screws.
 - d. Tape the rudder to the fuselage and mark the line of the tailwheel wire on the rudder. Remove the rudder from the fuselage and drill a 1/16" hole for the tailwheel wire. 'Harden' the hole with thin CA and redrill the hole after the CA has cured.
 - e. Trial fit the rudder with hinges to the tailwheel wire, bracket and rear of fuselage. If everything works smoothly glue the hinges and the tailwheel wire.
 65. a. Although the interplane connections require a fully assembled aircraft to complete, you should mark and drill the holes for the aileron interconnect horns in the ailerons. Don't forget to harden the holes with CA and to redrill the holes after the CA has cured.
 - b. Hinge all four ailerons, making sure you glue the torque rods to the lower aileron only and not the brass tubing bearing. The hardest part of this kit is now behind you.

The secret to successful soldering is cleanliness. Sand the wire and the washers, then wipe them clean with alcohol. Begin the job by soldering the inner washer, which can be held in place with a temporary piece of heat-proof silicone fuel tubing

(1). When cool, install the tailwheel followed by a thin cardboard spacer and the outer washer.



(2). Solder the washer, allow to cool, then remove the cardboard spacer. Grind off the excess wire and file the end smooth.

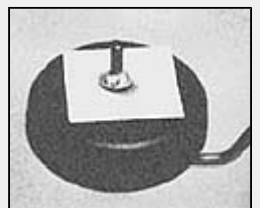

(3). Done properly, this installation should be completely trouble free.

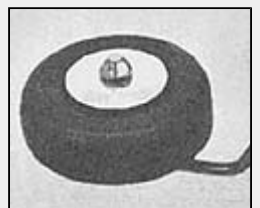

Tank Installation

BUILDERS TIP:

An easy way to guide the lines through the firewall holes is to use two long pieces of 4-40 threaded rod. Thread the rod from the nose of the airplane through the firewall and into the radio space. Leave each line a little long and push the end of each line over a threaded rod. As you insert the tank gently pull on the threaded rods to guide the fuel line through the firewall.

66. a. Assemble the tank per the manufacturers instructions, add carburetor and pressure lines and slide the tank into the fuel compartment. Blow in the carburetor line and check for free flow of air. It's much easier to fix any problems before anything else gets in the way.
- b. Pack around the tank with styrofoam or foam rubber to prevent shifting during flight and to reduce fuel foaming from vibration.
67. a. The most convenient way to mount the servos is to use the trays that come with the radio. Follow the radio manufacturers instructions for mounting the servos, packing the battery and receiver and mounting the switch harness and charge jack.
- b. The servos tray mounted in the fuselage (rudder, elevator and throttle) should be screwed to a pair of mounting rails. Servo mounting rails for the fuselage should be cut from the 3/8" x 3/8" basswood provided. The location of the rails should be established based on the desired balance point of the airplane. The position shown on the plans should be close for the average weight engine. A heavier or lighter engine or tail surfaces may require shifting the rails fore or aft to help balance the airplane.
- c. The aileron servo can be mounted directly to the center of the lower wing with or without the tray.
- d. The switch harness and charge jack can be mounted in the cockpit area for easy access but will still be protected from the engine exhaust.
- e. Don't worry about the location of the receiver or battery pack until we do the final assembly of the airplane.
68. a. Trim the servo end of the outer pushrod for the elevator (pushrod closest to the bottom of the elevator) so that it extends forward beyond former F5 about 2".
- b. Make up the control surface end of the elevator inner pushrod first. Cut one of 2-56 threaded steel rods to 3-1/4". Slide the plain end of the threaded rod into one end of a 13/64" outside diameter (inner part) nylon tube and screw the threaded section of the rod about 3/16" into the nylon tube. Wick some thin CA down the threads of the rod into the tube to lock the threaded rod in place. Thread a nylon clevis on the exposed end of the threaded rod until the threads are through the clevis.
- c. Tape the elevators firmly in the neutral position and install an inner pushrod assembly in the outer tube closest to the bottom of the stabilizer. Using the plan and the pushrod assembly as guides mark the location of the two holes for bolting on the elevator horn. Drill a 3/32" hole at each mark. 'Harden' the hole with thin CA and after the glue has cured redrill the hole. Bolt the elevator horn in place with two #2 x 3/4" sheet metal screws and clip the clevis to the horn. Operate the elevator by moving the servo end of the pushrod to check for easy, slop-free motion of the elevator. Correct any binding or excess slop before proceeding to the next step.
- d. Re-tape the elevators firmly in the neutral position. Cut off the inner pushrod tube about 1-1/4" from the elevator servo arm. Take the shortened 2-56 threaded rod and screw the threads completely into the servo end of the elevator pushrod. Slide a 2-56 solder link onto the wire pushrod, line the linkpin up with an outer hole in the servo arm, mark the correct length of the wire pushrod and cut off the wire. Solder the link to the wire.
69. Repeat step 68.a. through 68.d. for the rudder pushrod.
70. a. Find F-5B pushrod support and place it against Former F-5 above the pushrods. Mark the location where the two pushrods should go through the support and drill a 9/32" hole at each mark.
- b. Thread the pushrods through the pushrod support and slide the pushrod support against F-5. Tack glue the pushrod support in place.
- c. Cycle both servos with the radio to make sure that nothing hangs up and that everything operates freely. If everything operates correctly glue the pushrod support and pushrod outer sheath permanently in place.
71. a. Locate the servo end of the throttle cable and make up a support out of scrap materials to locate the outer tube in line with the arm of the servo.
- b. Sweat solder both ends of the 1/16" steel cable for at least 1" to help support the ends that extend past the outer tube. Slide the cable into the outer tube and check for any binding that may re-sult from too tight a bend. Correct any problems now.

- c. Assemble a pushrod connector to the engine throttle arm, reassemble the engine to the firewall, thread the 1/16" steel cable from the radio compartment to the engine pushrod connector and connect the cable to the engine. Slide a solder clevis onto the servo end of the 1/16" steel cable, set the servo and throttle position correctly and solder the clevis to the cable. Check the travel of the servo versus the throttle linkage and make the appropriate adjustments.
- 72a. Locate the nylon aileron connectors and cut them apart. Screw the connectors on the bottom wing torque rods until they are about 1/8" past the end of the torque rods.
- b. The aileron pushrods are made from two 2-56 x 10" threaded steel rods. Thread a nylon clevis on the two remaining threaded rods until the threads are through the clevis. Connect a clevis to each aileron connector.
 - c. Slide a solder clevis onto each threaded rod and line the linkpin up with the outside hole in the servo arm. Mark the length of the pushrod and cut the pushrod to length.
 - d. Tape the aileron torque rods in the neutral position, connect the solder clevis to the servo arm and solder the clevis to the pushrod.

Mounting Wheel Pants

- 73a. Install the 3" main wheels on the landing gear using the hardware shown in the drawing. Try a little thin CA on the inside nuts to keep the axles from coming loose.
- b. With two or three small pieces of masking tape line up and join the wheel pant halves. Spot glue the joint with thin CA, remove the tape and glue the complete seam with medium CA.
 - c. Cut out the bottom of the wheel plant to accept the wheel mounted in part a. Reglue the inside seam of the wheel pant with medium CA.

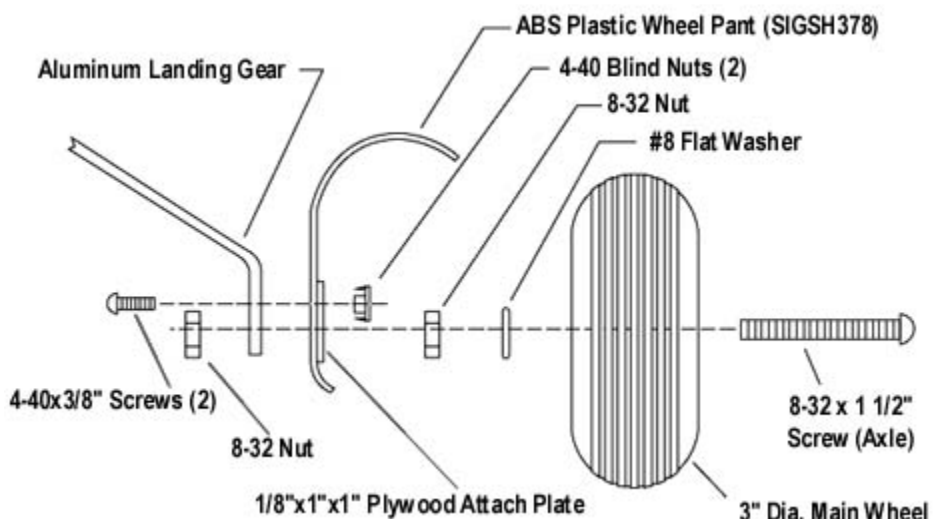

- d. Using the plans as a guide glue the attach plate to the inside of each wheel pant with the slot down. Slot the wheel pant to match the mounting plate and drill two 1/8" holes in the wheel pant as indicated by the holes in the mounting plate. Trial fit the wheel pants to the landing gear.
 - e. Install a 4-40 blind mounting nut in each of the holes just drilled and seat them with the 4-40 bolts. Spread epoxy glue over the blind nuts to hold them in place. Be careful not to get any glue in the threads of the blind nuts.
 - f. Mount the landing gear to the fuselage with three 6-32 x 1/2" machine screws.
- 74a. Trim the headrest to fit the top of the fuselage behind the cockpit. Sand the headrest lightly to remove any dirt or oil.
- b. Finish with the headrest and the wheel pants with your favorite method.
 - c. Glue the headrest to the top of the fuselage.
 - d. Assemble the wheel pants to the landing gear.

Wing Assembly

- 75a. Insert the cabane assembly into the top of the fuselage and check the alignment of the holes in the aluminum cabane with the holes in the fuselage. This is a very critical step - this determines the incidence of the top wing. Get the incidence wrong and you've got a real pig on your hands; get the incidence right and you've got a Hog Bipe just waiting to go. If everything checks out bolt the cabane assembly in place with four 4-40 x 3/4" pan head machine screws and #4 washers.

- b. Bolt the bottom wing to the fuselage with the two 1/4-20 nylon bolts. Bolt the interplane struts to the outside of the bottom wing strut mounts with four 4-40 x 3/8" socket head capscrews and #4 washers. Do not tighten the bolts yet.
- c. Bolt the top wing to the cabane with two 8-32 x 1" nylon screws. Make sure the interplane struts are on the outside of the top wing strut mounts. If everything is correct, the interplane struts should line up with the center of the top wing strut mounts without forcing anything. Using the top wing strut mount as a guide mark and drill a 7/64" hole in the top center edge of the interplane strut. Bolt the interplane struts to the top wing strut mounts with two 4-40 x 3/8" socket head cap screws and #4 washers.
- 76 a. Using the two 8" 4-40 threaded rods thread a 4-40 nut and clevis on one end and a 4-40 size solder clevis on the other. Snap the threaded clevis onto the bottom left aileron interconnect horn.
- b. Tape the top ailerons in neutral position, turn on the radio and center the bottom ailerons. Then solder the clevis at the top aileron, interconnect horn to establish the correct length of the aileron interplane pushrod.
- c. Repeat steps 76a. through 76c. for the right aileron interplane pushrod.

Final Points

77. Install all the radio equipment and check the balance of the completed aircraft. If you need to move the balance point the battery pack is the heaviest moveable item. If this is not enough you might try moving the receiver - or horrors, add a little lead in the appropriate spot.
DO NOT FLY WITH THE AIRPLANE TAIL HEAVY - YOU WILL PROBABLY CRASH.

The balance points or centers of gravity (CG), measured from the leading edge of the top wing, are:

25% 3-5/8" Good place to start if this is your first biplane.

30% 4-1/8" Better elevator response and quicker snaps.

35% 4-5/8" Approach this CG with precaution. Unexperienced pilots may find this to be to extreme for their ability.

For the first flights it would be a good idea to have the Hogbipe balanced at a more forward CG rather than a rearward CG. The control throws are as follows:

- Aileron; 5/8" up and down
- Elevator; 3/4" up and down
- Rudder; 1-1/4" left and right

After quite a few flights the SIG Factory Flyers have settled on these throws as a comfortable starting point. None of these throws will result in a dangerously slow response, nor will you find the controls too wild. After a few flights you may decide you want to change the response of one or more controls or to change the CG.

By all means do so, but be careful, it's entirely possible to make the Hog Bipe unmanageable by either a too rearward CG or too much control throw or a combination of both.

STOP,
before you go out and fly your new Hog-Bipe, make one last check of the airframe. Did you forget anything along the way that might have an adverse affect on the first flight? Plug in the charger and give it a little time while you review your handiwork. Look over the airplane very carefully and be critical - did you screw up anything?





HOG-BIPE

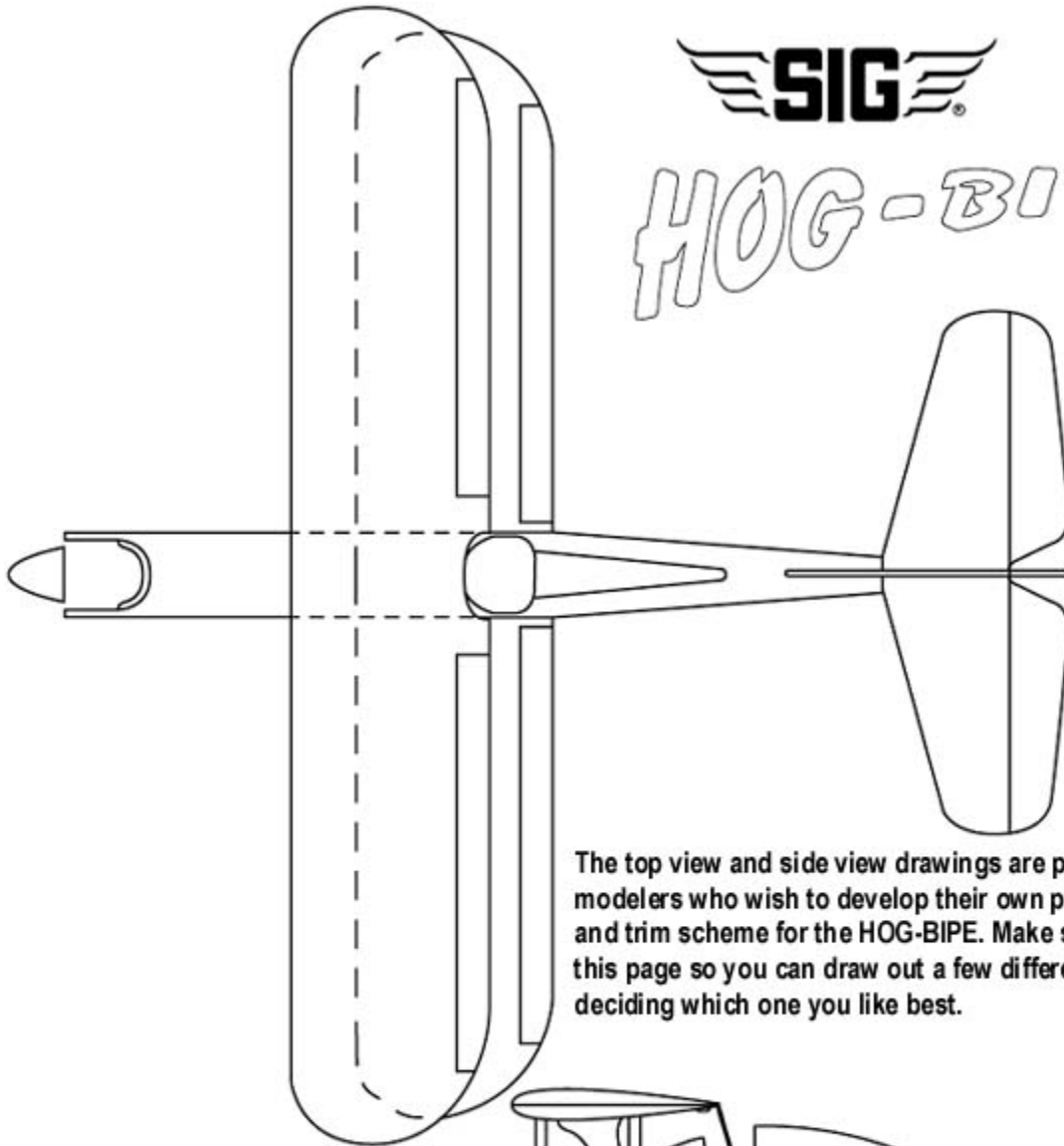

The top view and side view drawings are provided for modelers who wish to develop their own personalized color and trim scheme for the HOG-BIPE. Make several copies of this page so you can draw out a few different ideas before deciding which one you like best.

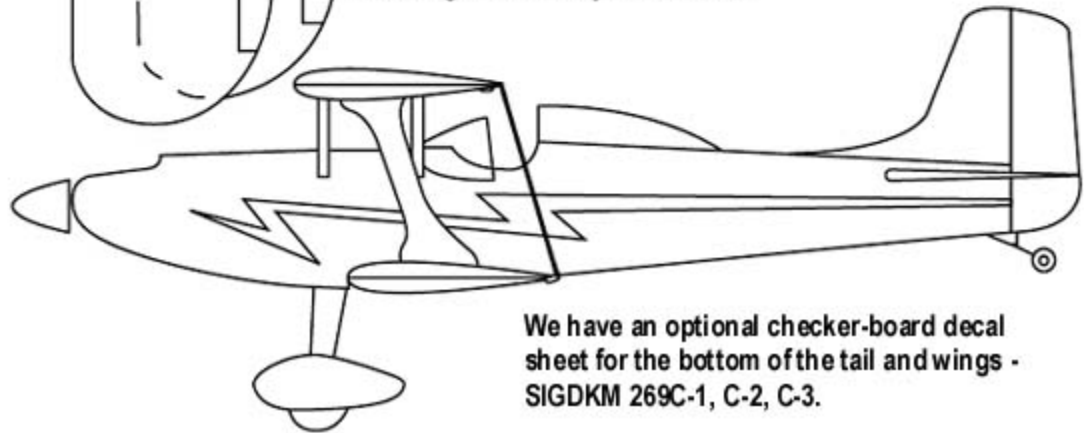

We have an optional checker-board decal sheet for the bottom of the tail and wings - SIGDKM 269C-1, C-2, C-3.

We sincerely hope that you enjoy building and flying your SIG HOG-BIPE. If you have any questions, comments, or problems with this kit or any other SIG product, please call us at: **641-623-5154 Weekdays, 7:30 am - 4:30 pm Central**

© Copyright SIG Mfg. Co., Inc.

SIG MFG. CO., INC.....Montezuma, Iowa 50171-0520

LIMIT OF LIABILITY:

In use of our products, Sig Mfg. Co.'s only obligation shall be to replace such quantity of the product proven to be defective. User shall determine the suitability of the product for his or her intended use and shall assume all risk and liability in connection therewith.