

(k.) Make a spacing block from scrap wood as shown in the accompanying isometric drawing. This should be 4-1/16" long to maintain the spacing between the struts. Use a screw at each end to hold it temporarily in place. If the front and rear sets of cabane struts are parallel, 0 degrees incidence will be maintained automatically.

(l.) Fit the 3/32" brace wire between the front and rear cabane struts and bind on the fine copper wire. Solder permanently together. The spacing block can now be removed.

(m.) Cut the 1/8" x 1/4" balsa strip to fit on the cabane struts as shown on the plan and epoxy the pieces in place on the wires. Sand a small rounded depression in the balsa to make it fit tightly against the wire. Allow the epoxy glue to squeeze out around the wire and when the glue starts to set up it can be trimmed off flush and later sanded smooth.

(n.) Put a scab of epoxy glue over the ends of the grooved hardwood blocks where the cabane strut wires enter.

(o.) Plug the holes in the plastic fuselage top around the cabane struts with Sig Epoxolite Putty. Fillet the putty against the wires and balsa stream-

Cabane Strut

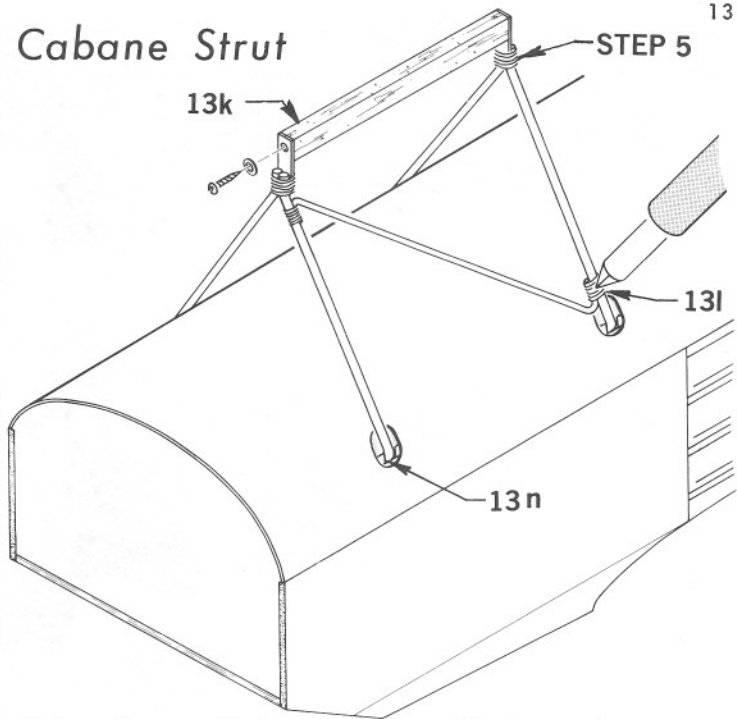

lining pieces. Before the Epoxolite has set up completely, carve it flush with the plastic fuselage top.

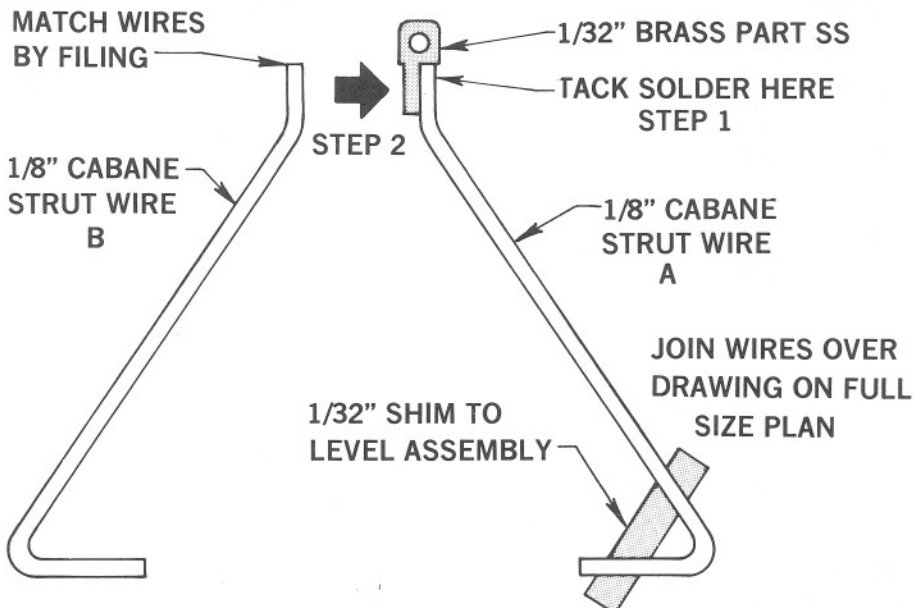

- STEP 1 - TACK SOLDER PART SS TO ONE CABANE STRUT WIRE (A).
- STEP 2 - TEMPORARILY FASTEN THE SECOND CABANE STRUT WIRE (B) TO THE FIRST WITH 5-MINUTE EPOXY GLUE.
- STEP 3 - TURN FIRST PAIR (AB) OVER AND REPEAT THE PROCESS WITH THE OTHER SET OF CABANE STRUTS WIRES (CD).
- STEP 4 - CUT OFF THE EPOXIED WIRES, CLEAN METAL WITH SAND-PAPER AND REASSEMBLE IN THE FUSELAGE GROOVED HARDWOOD BLOCKS.
- STEP 5 - BIND TIGHTLY WITH COPPER WIRE AND SOLDER PERMANENTLY.

FOR PERFECT TOP WING ALIGNMENT, MAKE THE CABANE STRUT SETS EXACTLY ALIKE.

Making The Cabane Struts

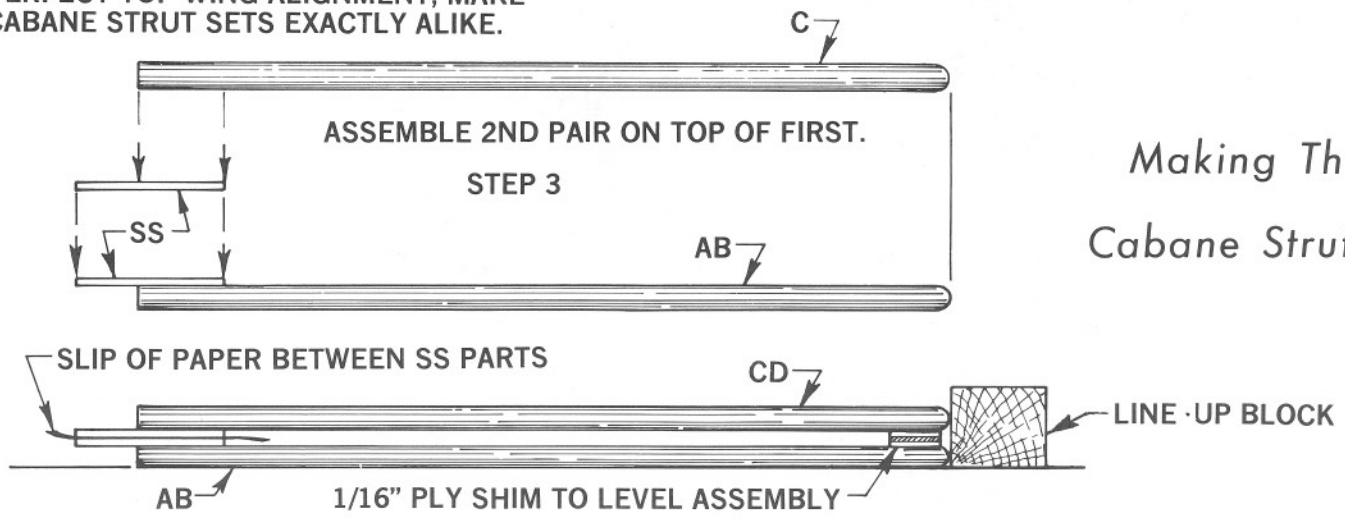

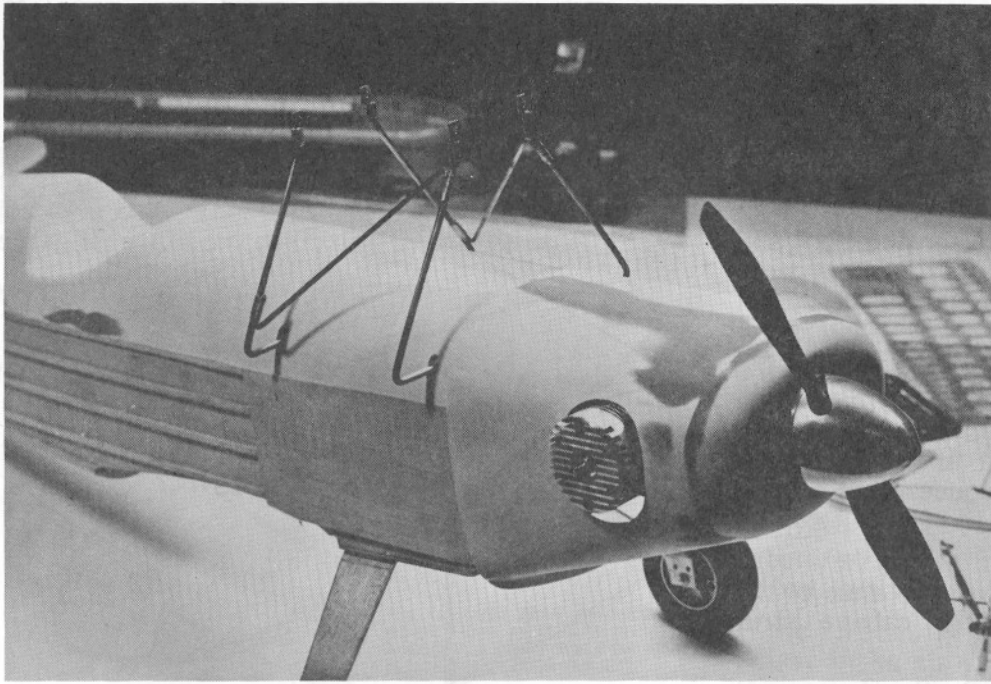

OPTIONAL CABANE STRUT

This ingenious method of making the cabane struts for the Skybolt was developed by Jerry Smith and was featured in his "Here's How" column in the March 1976 issue of R/C Modeler magazine. It has the advantage of doubling the wearing surface of the brass parts as well as aiding in assembly of the model.

If you prefer a metal top wing attachment rod rather than a dowel, use a piece of brass tubing instead of a music wire or steel rod. Prolonged use of a steel rod causes the hole in part SS to wear. This applies whether you use the kit or Smith's method. Some fliers have used a nylon rod.

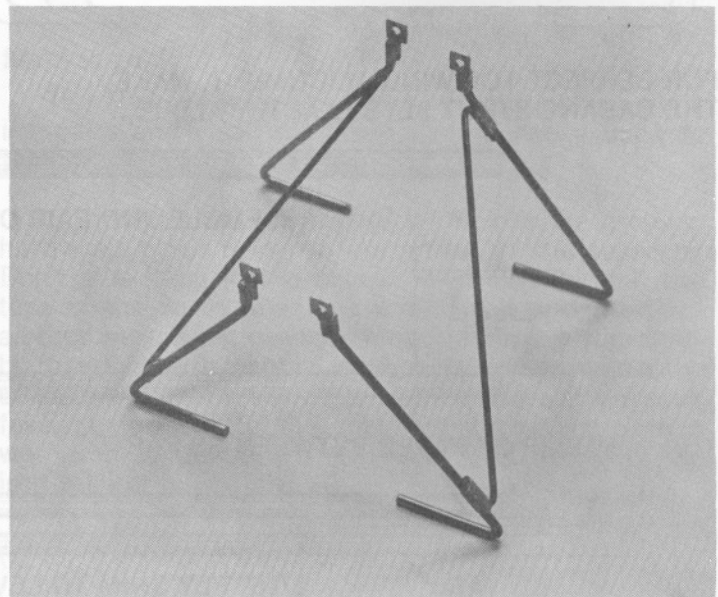
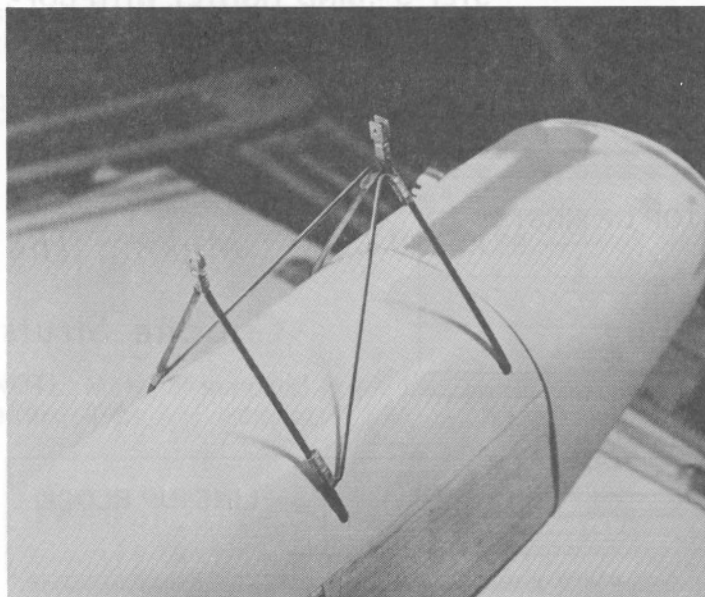
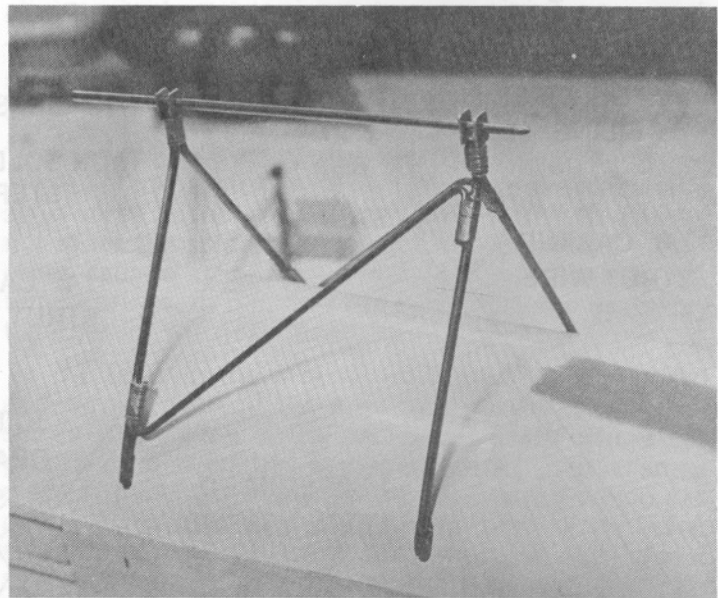
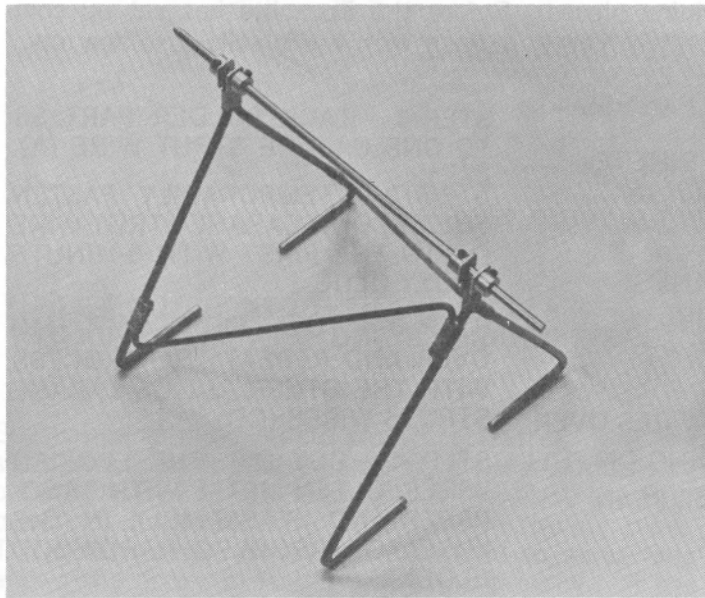

Having at least three R/C Biplanes in the hanger would indicate that I fall into the category of a Bipe addict. Everytime I see a new Bipe I have to fight off the urge to build it. And, so it was that day I sat in the Hobby Shop reading thru "The Building And Flying Manual" on Sig's Skybolt Bipe. Not having built a Sig kit for a number of years, I decided, on the basis of what this excellent kit had to offer, to renew my acquaintance.

Claude McCullough's efforts are certainly evident throughout the kit. The building and flying instructions manual (Most complete and informative that I have seen in some-time) supplemented by a good set of plans, easily lead you thru the building phase. In a recent note to me, Claude explained. "We put a lot of sweat into it, trying to make it a good kit that would sell for a reasonable price. Now, since balsa and other things are still going up, I suppose we will have to increase the price in time. The Skybolt is selling very well and we get lots of good comment on the way it builds and flies."

Building the Skybolt, my constructive discontent began to show up again. This time it was the method of building the cabane struts. I have always found it difficult to finish the fuselage while working around these struts. A real headache! So-why not make them removable! The result? A nice clean fuselage to finish with the added convenience of building and finishing the struts off the airplane. Why not!! The following information and sketches will make clear my modification for removable cabane struts on Sig's Skybolt. This method may also be used on other aircraft with cabane struts of similar arrangement. If you are thinking Bipe, you will be extra pleased with Sig's Skybolt kit. I was!!

ABOUT THE FUEL TANK INSTALLATION

We occasionally receive suggestions from builders that a removable hatch be designed into a model for access to the gas tank. Our opinion is this is not the best method. The hatch opening makes the nose weaker and there is no good way to keep oil from leaking in around the hatch. Fasteners must be built in to hold a hatch in place.

Modern plastic tanks are virtually indestructible under normal use and bursting or cracking is almost unknown. If you use Sig Heat Proof Silicone tubing (which will not harden or deteriorate in fuel) in the plastic tank, the tank will seldom have to be removed. We have models in which the tank has been installed for three or four years without ever needing removal. So it is quite practical to put the tank in semi permanently. Put scrap wood supports under and at the back of the tank. The front is supported by the 7/8" hole in the firewall. Seal the tank cap in the hole with G.E. Silicone Bathtub Seal (hardware stores) or Devcon Seal-It (available from Sig.) You can stuff paper toweling on each side to keep it wedged in place. Some builders, after putting their receiver battery in a plastic sack, taping it shut, wrapping it in a foam rubber package and stuffing it into the nose under the tank, then stuff more paper toweling or foam rubber in to fill the nose. Others prefer to put in scrap balsa side supports to hold the tank in position.

Check the models at a contest-you'll find that the majority

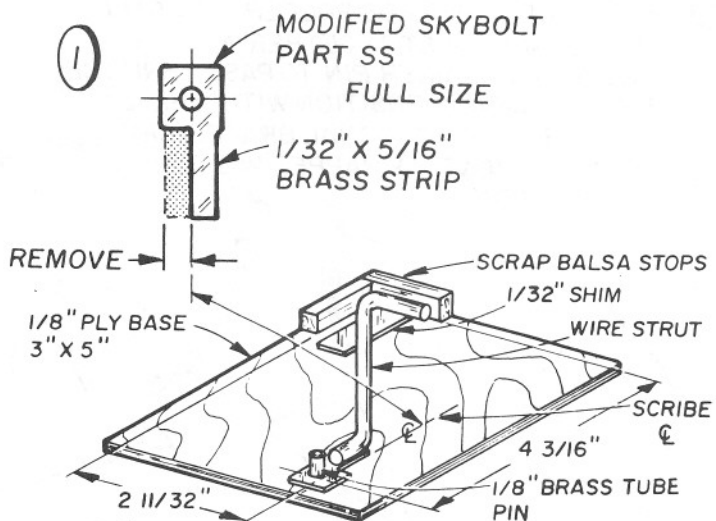

2 RECOMMENDED SOLDERING JIG
THIS SIMPLE SOLDERING JIG WILL ENSURE ACCURATE ALIGNMENT OF FINISHED STRUTS. PLACE EDGE OF WIRE STRUT AND BRASS PART ON SCRIBED C . PLACE A WEIGHT ON THE STRUT TO HOLD DOWN. NOW TACK SOLDER PART TO STRUT.

3 WRAP JOINT WITH SOFT COPPER WIRE FLUX WELL AND SOLDER. MAKE SURE ALL VOIDS ARE FILLED WITH SOLDER. USE A 250 WATT IRON.

4 FILE, AS SHOWN, DOWN TO WIRE STRUT. MAKE SURE THAT SURFACES ARE FLAT AND REASONABLY SQUARE.

NOTE: ALL FOUR STRUTS ARE MADE EXACTLY THE SAME

of them have sealed noses, as does this kit. Should you ever need to remove the tank, it is a simple matter to break out the scrap supports and push out the silicone rubber seal around the front cap. Reach into the fuselage and guide the tank outside.

SPECIAL TIP: Test install the tank and check for ease of placement and replacement before closing up access to the interior of the nose of the model. The vent tubes, for example, must not be too long.

After installation of the tank, put fuel tubing on the vent tubes and run it to the outside of the cowling for easy tank filling. The best way to fill the tank is to take off the fuel line to the needle valve and pump the fuel in there until it runs out the vent. Or, if access to the needle valve is not convenient, a third line may be added in the extra hole provided in the rubber tank top of Sig and most plastic tanks. It is a good idea to run the overflow vent out the bottom of the cowl so any fuel leakage is not sprayed on the canopy.

- 5 ASSEMBLE STRUTS ON AIRCRAFT. IF YOU HAVE FILED THE ENDS PROPERLY IN STEP 4, THEY WILL NEST TOGETHER ALLOWING THE WING RETAINER PIN TO PASS THRU THE HOLES. ALIGN IN POSITION WITH WHEEL COLLARS. THE DIAGONAL BRACES ARE NOW POSITIONED, WRAPPED WITH WIRE AND SOLDERED.

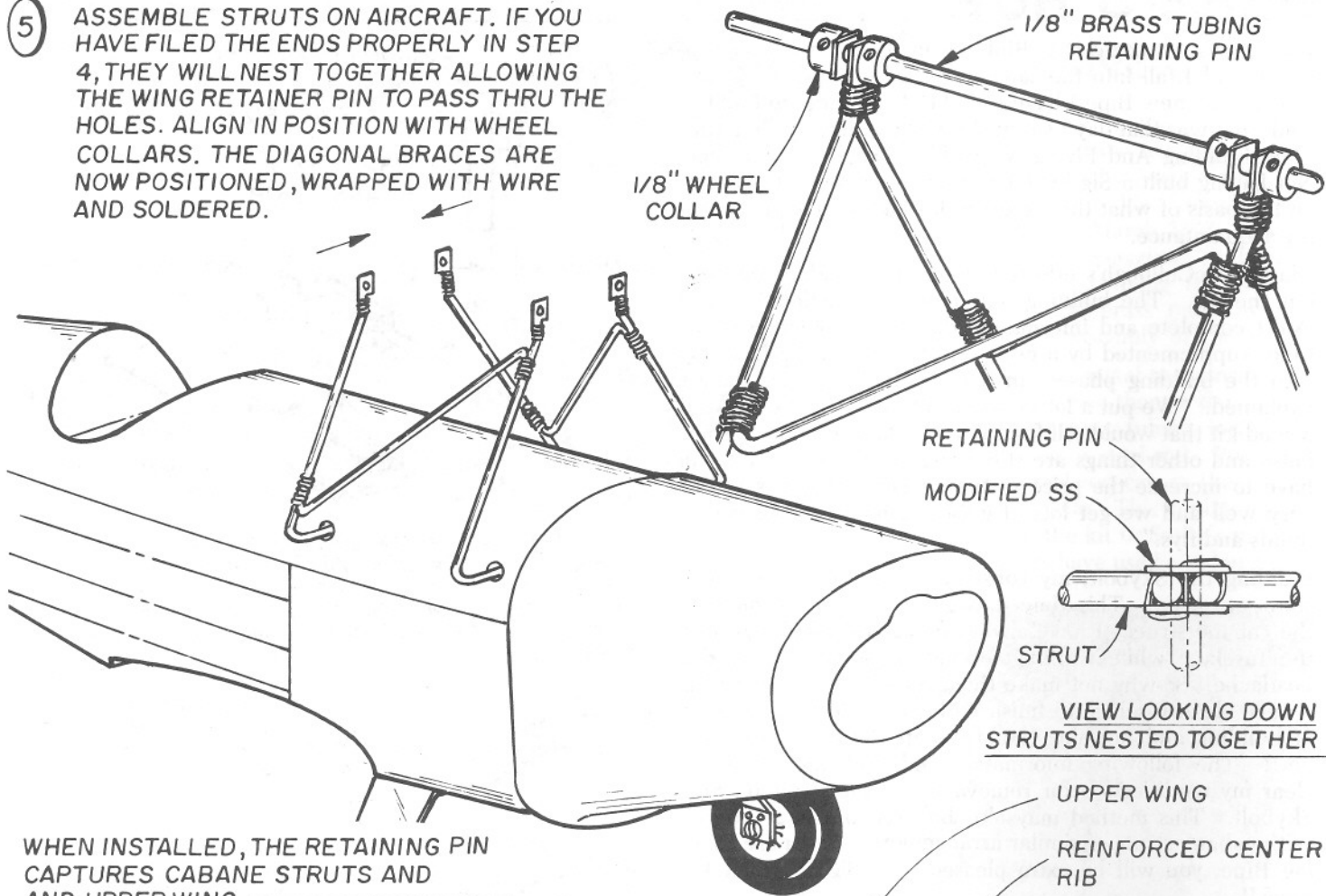

WHEN INSTALLED, THE RETAINING PIN CAPTURES CABANE STRUTS AND UPPER WING.

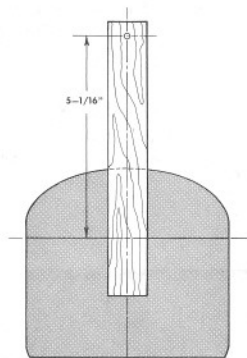

**BOB LILLIE'S
STRUT JIG**

Bob Lillie (Milwaukee, WI) used a simple method of alignment for the cabane strut assembly. He tack glued a ply piece to the firewall with a hole exactly $5\frac{1}{16}$ " on center from the thrust line mark on the cowl. The same spot is located on the leading edge of the fin. (This would be $5\frac{1}{16}$ " above the thrust line, but for easier measurement, use $4\frac{7}{16}$ " above the stabilizer top or $4\frac{1}{16}$ " above the fuselage top if the stabilizer is not yet in place. A small scrap wood support is tack glued here to hold the end of a 36" piece of music wire. The music wire rod is run through the front ply piece, the cabane strut brass parts and on to the fin during checkout and assembly of the strut. This procedure will assure exact O-O alignment with the thrust line. Before permanent assembly, be sure and check out the wing alignment as shown by the drawing on the full size plan.

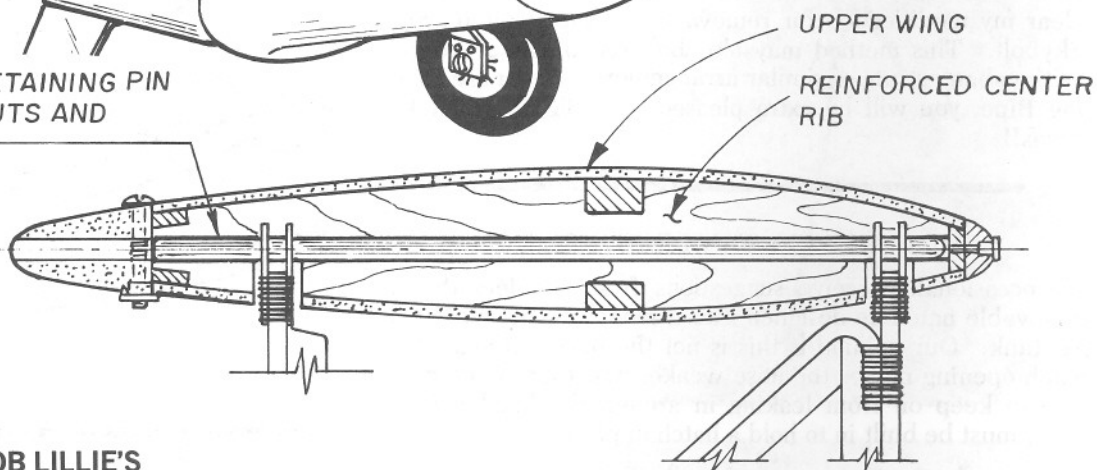

OIL PROOF YOUR MODEL!

One of the most destructive things that can happen to a model is allowing engine oil to soak into bare, untreated balsa or plywood. It will cause glue joints to loosen and results in a steady increase in weight. An oil soaked model cannot be properly repaired or re-painted after a crackup, since glue and finish will not hold. Cover all wood parts of the model and put on enough coats of finish so that oil cannot soak in. Don't leave any exposed wood on the outside. Around the nose and engine compartment, apply extra effort at oil proofing. Coating the firewall and front joints with epoxy glue is best, but several extra coats of dope or paint will also do the job. Take special care during building to use plenty of epoxy glue to attach the firewall and coat the back of the firewall and the firewall braces with the glue. Fill any cracks with epoxy.

Skybolt Alternate Color Scheme

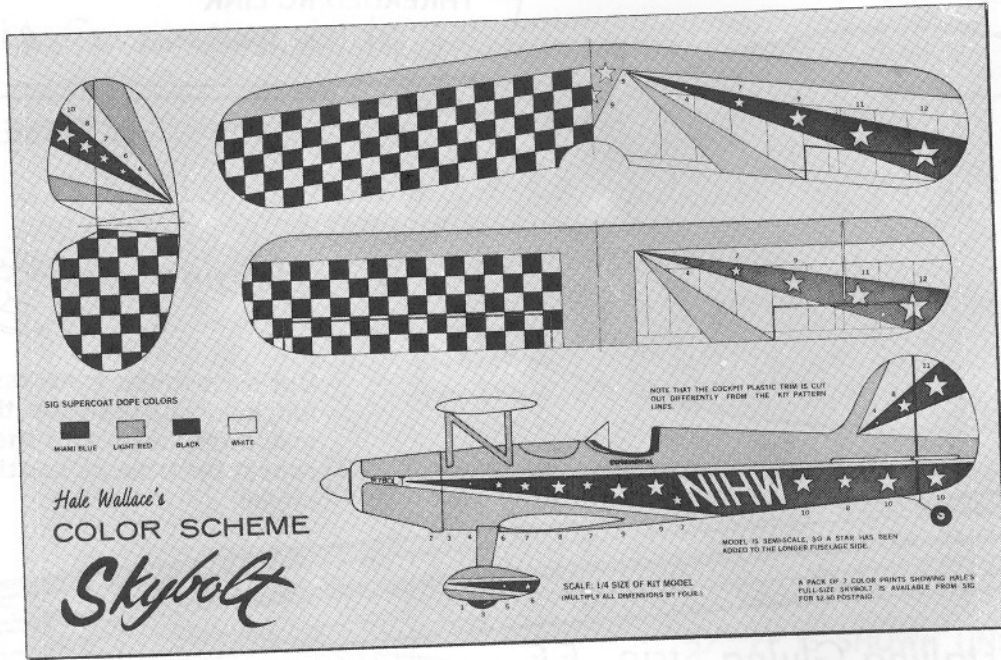

Paint your model like Hale Wallace's spectacular version. A color photo of his EAA prize winning Skybolt appears in the Sig catalog.

- Decal Set consists of:
- 2 - 8-1/2" x 11-1/2" Decal sheets
 - 1 - 10-3/4" x 17" Quarter size color layout plan of the kit model.

On the reverse side of the plan are 8 black and white photos of Hale's airplane.

Order DK-200

A Pack of Seven Color Prints Showing Hale's Full-Size Skybolt Is Available From Sig - PP-400

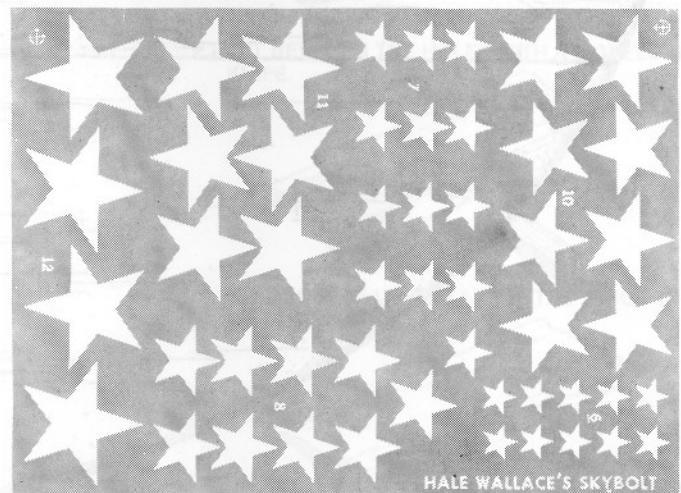
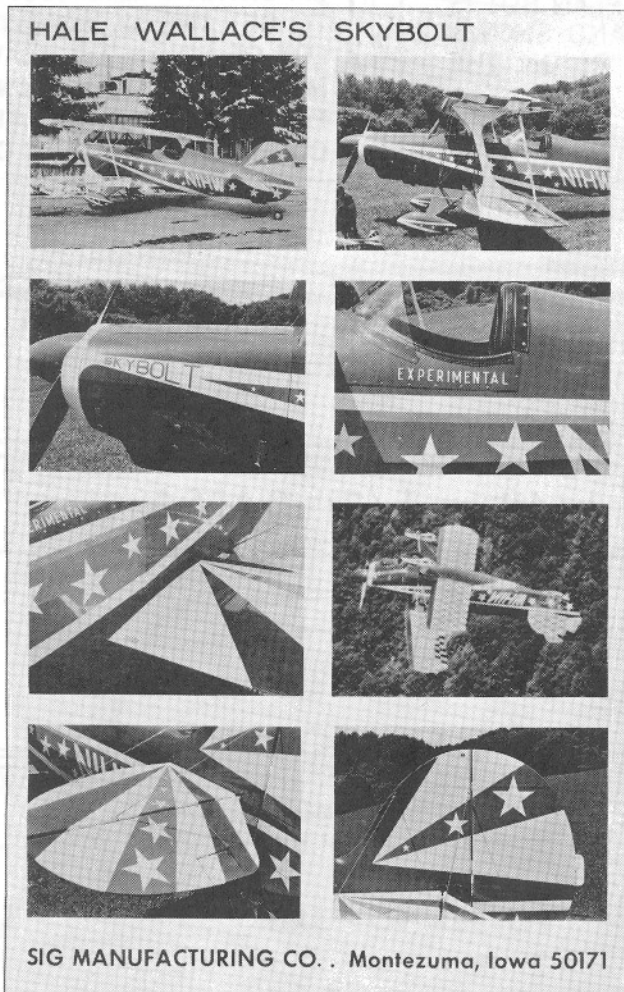

SIG MANUFACTURING CO. . . Montezuma, Iowa 50171

Windshield Pattern

CUT FROM CLEAR PLASTIC WITH SCISSORS

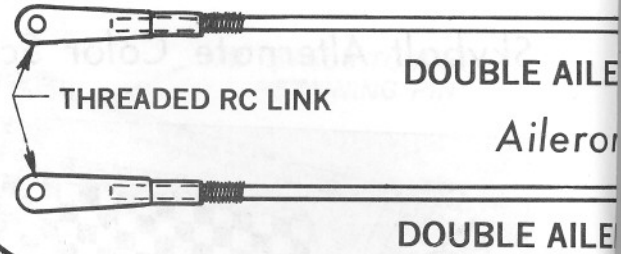
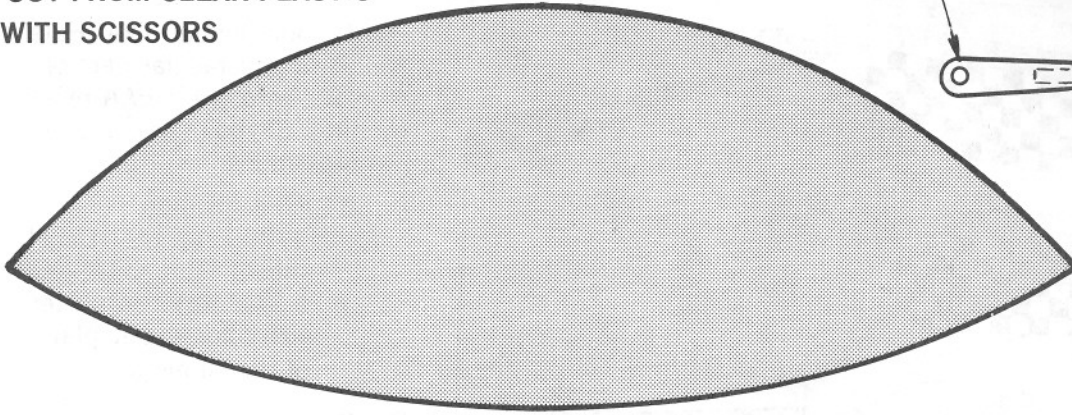

Hinging



Cut slots in the control surface hinges. Fill the slots with Sig K insert the hinge into the slot. repeat the process to attach the model.

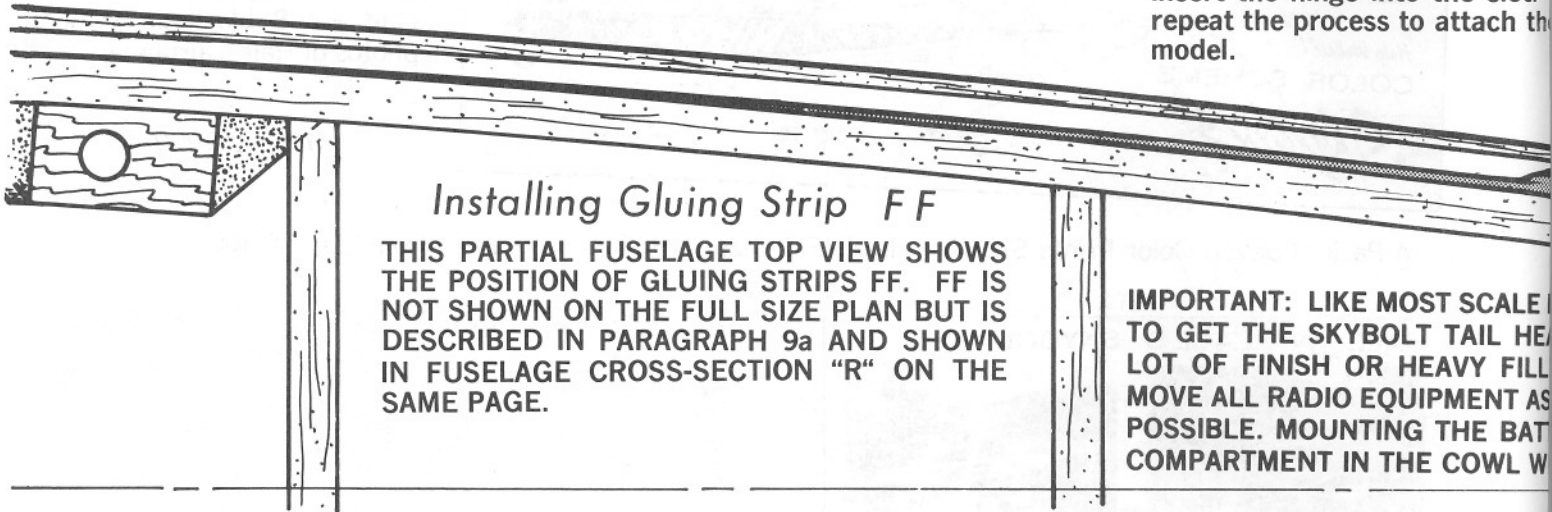

Installing Gluing Strip FF

THIS PARTIAL FUSELAGE TOP VIEW SHOWS THE POSITION OF GLUING STRIPS FF. FF IS NOT SHOWN ON THE FULL SIZE PLAN BUT IS DESCRIBED IN PARAGRAPH 9a AND SHOWN IN FUSELAGE CROSS-SECTION "R" ON THE SAME PAGE.

IMPORTANT: LIKE MOST SCALE MODELS TO GET THE SKYBOLT TAIL HEAD TO GET A LOT OF FINISH OR HEAVY FILL. MOVE ALL RADIO EQUIPMENT AS POSSIBLE. MOUNTING THE BATTERY COMPARTMENT IN THE COWL WILL

HINGE

1/4" x 1/2" BALSA

ELEVATOR

Elevator Assembly View

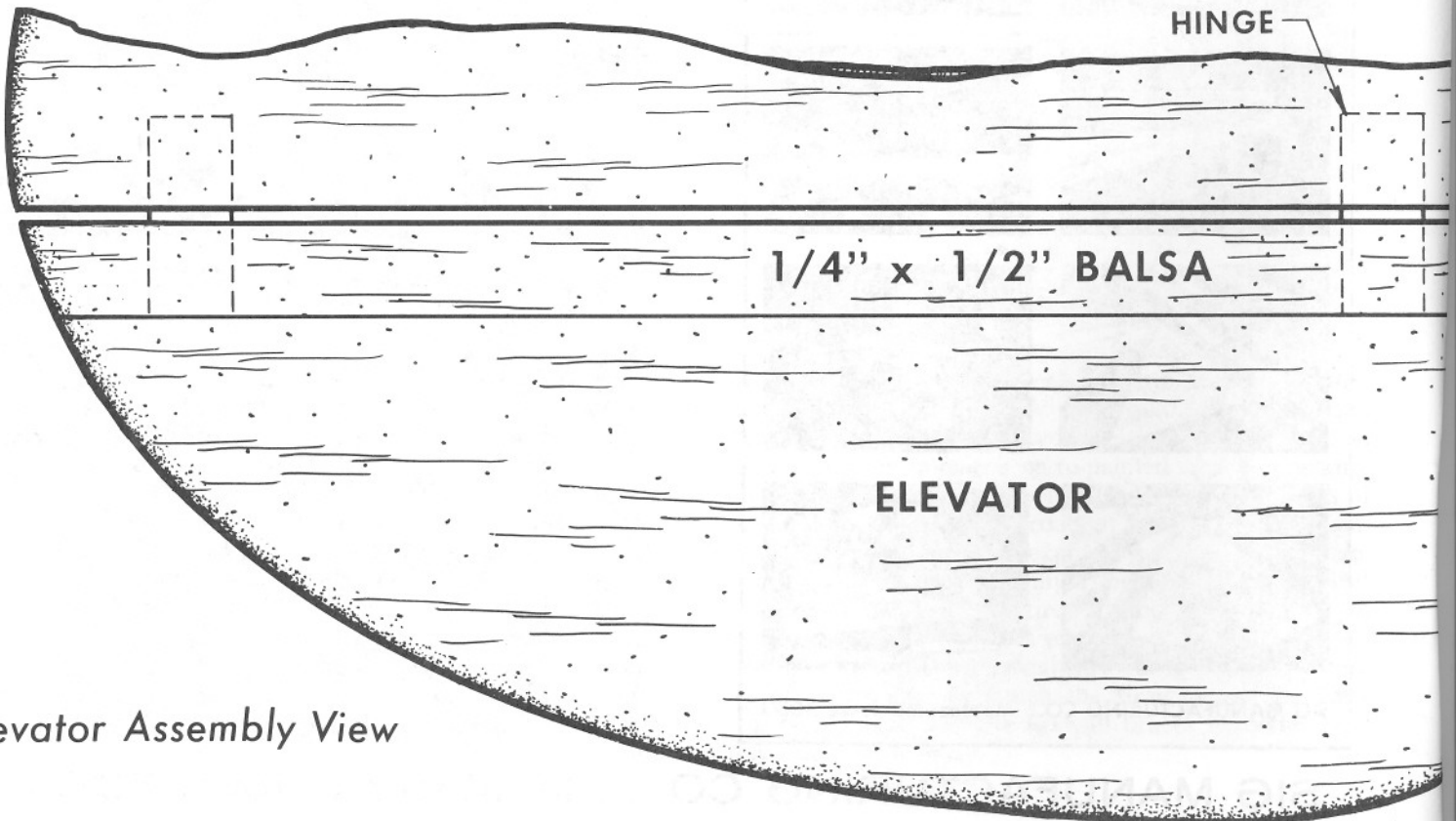

ON LINKAGE - TYPE A
Inter-Connecting Rods

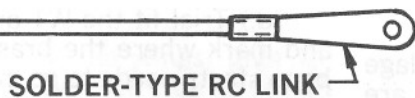

ON LINKAGE - TYPE B



Removing The Jigs

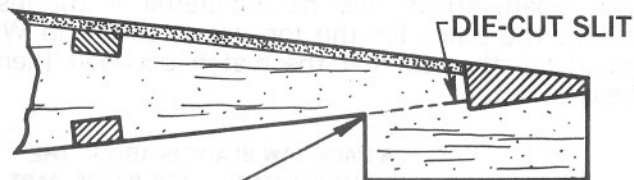

CUT FROM FRONT EDGE OF JIG TAB TOWARD DIE-CUT SLIT IN THE BACK.

CONTROL MOVEMENTS USED ON ORIGINAL MODEL

RUDDER - 1" EACH WAY
ELEVATOR - 7/8" DOWN, 1" UP

Aileron Movement

ADJUST LINKAGES FOR THIS AMOUNT OF AILERON DOWN MOVEMENT BEFORE CLOSING UP WING.
(DOUBLE AILERON.)

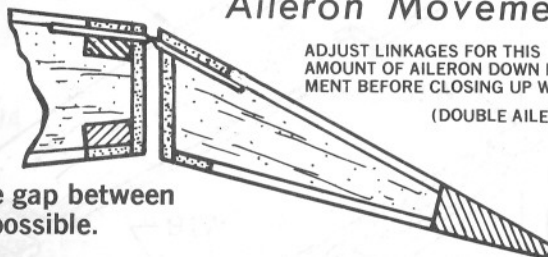

Note: For best control response, keep the gap between the surface and the model as narrow as possible.

to receive the molded
k-Set epoxy glue and
after the glue has set
control surface to the

1/8" PRINTED SHEET FUSELAGE SIDE IS SHOWN SHADED.

STABILIZER LEADING EDGE

FF IS SHOWN UNSHADED AND UNGRAINED.

1/8" SQ. TOP STRINGER ON SIDE

1/4" SQ.

MODELS IT IS EASY
Y. DON'T USE A
S ON THE TAIL.
AR FORWARD AS
RY IN A SEALED
HELP.

STABILIZER PART S-2

SCRAP 1/8" PLY INSERT

ELEVATOR HORN
ANGLE SLIGHTLY
FOR EASIER HOOKUP

3/32" WIRE CONNECTOR

MAKING A HINGE SLOT

1.) DRILL TWO 1/16" DIA. HOLES INTO THE WOOD.

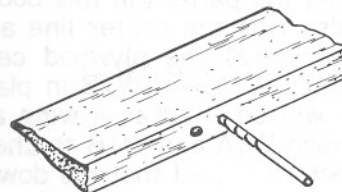

2.) CUT BETWEEN THE HOLES WITH A MODELING KNIFE.

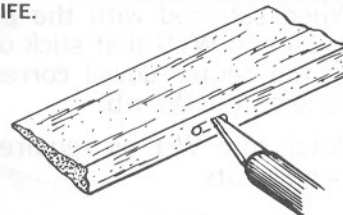

3.) USE EPOXY GLUE TO FASTEN THE HINGE IN THE SLOT.

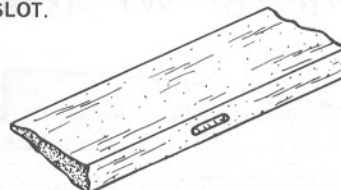

NOTE: AN X-ACTO KEYHOLE SAW BLADE NO. 15 IS ALSO HANDY FOR CUTTING HINGE SLOTS.

(14.) W1 RIB ASSEMBLY

The cabane struts must be completed on the fuselage before the parts for the top wing center rib W1 are glued together so that the match between them can be checked.

A HACK SAW BLADE IS ABOUT THE RIGHT WIDTH TO PASS BRASS PART SS

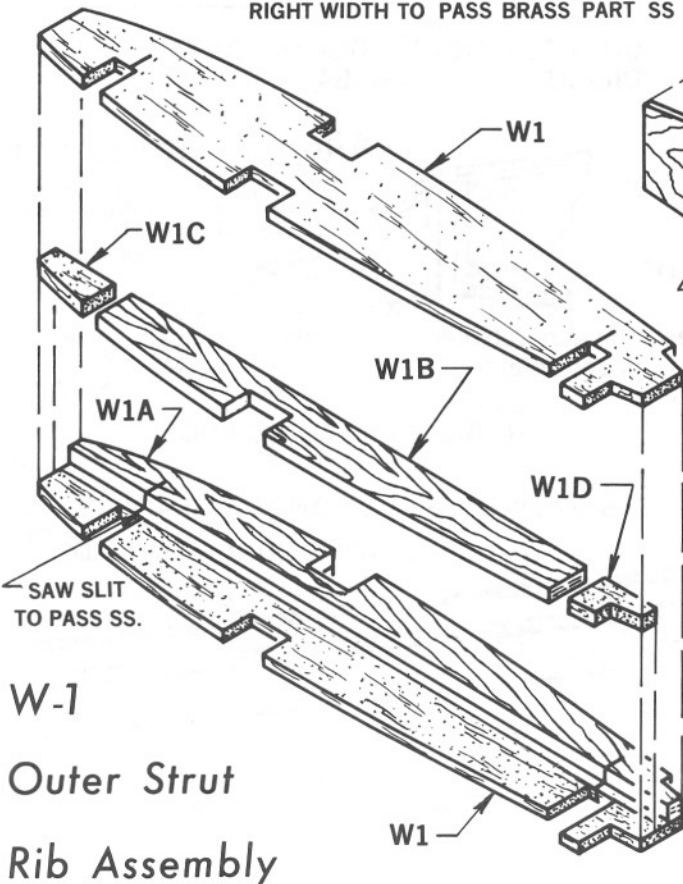

(d.) Trial fit the W1 assembly to the cabane struts and mark where the brass part SS on top of the cabane struts needs to go into W1A.

(e.) Use a hack saw blade to saw slots into W1A to pass the tops of brass parts SS on the struts.

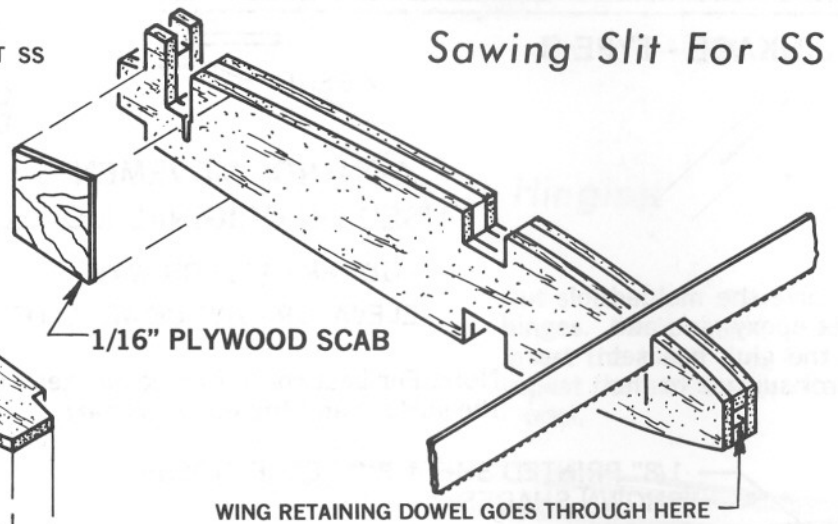

(f.) Check the fit of the W1 assembly on top of the cabane struts, using the dowel to hold it in place. It is probable that minor alterations in the notches will have to be made to clear the solder on part SS, etc. Cut away to fit, but don't make the openings any larger than absolutely necessary to make the assembly fit.

(g.) Add balsa pieces W1C and W1D.

(h.) Once you are certain that the assembly is fitted properly to the cabane struts and that the dowel can be inserted and removed easily, the second W1 balsa rib can be glued on top of the rest of the assembly. Keep the assembly true by lining up the rear key tab and the bottom of the first rib W1 with the second W1 rib.

(i.) Complete the saw cut made previously for SS through the second rib W1 just added.

(j.) If the plywood parts W1A and W1B protrude anywhere around the edges of the assembly, trim them down flush with the balsa W1 ribs.

(k.) Check the assembly again for ease of mounting on the cabane struts with the dowel.

(l.) Glue plywood scabs of 1/16" plywood on each side of the openings in the W-1 assembly. Make them full depth so that the planking will glue to them as well as to the rest of the W1 assembly.

(m.) The assembly can now be built into the wing in the same manner as the rest of the ribs.

(a.) Using the pattern in this book, draw on one of the W1 balsa ribs the center line and the lines indicating the edge of the plywood center pieces W1A and W1B. Lay W1A and W1B in place. Put the 1/8" dowel that will be used as a wing attachment pin in place between W1A and W1B to check that the spacing is correct. It is best that the dowel not fit so tightly that it will be difficult to remove.

(b.) When satisfied with the position (ignore any edges of W1A and W1B that stick out and concentrate on getting the center dowel correct), glue W1A and W1B in place on the W1 rib.

(c.) Notch into W-1 as required to pass the top of the cabane struts.

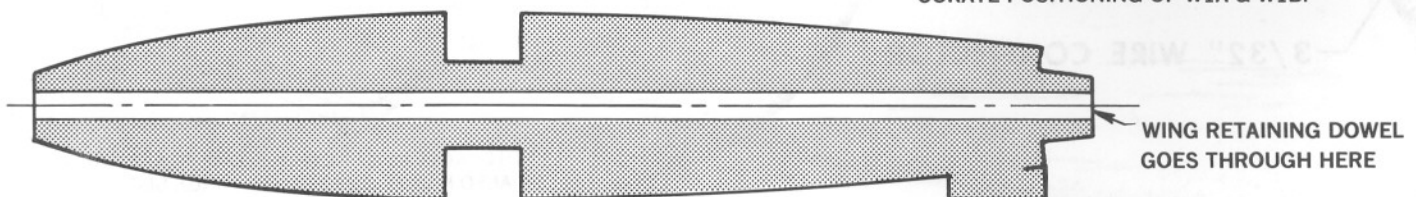
Pattern For W1 Assembly

PATTERN FOR W1 CENTERLINES. USE FOR ACCURATE POSITIONING OF W1A & W1B.

WING RETAINING DOWEL GOES THROUGH HERE

(15.) OUTER STRUT RIBS

Before beginning construction of the wings, glue together the W4, WA, and W5 sandwiched ribs as shown in the accompanying drawing. This forms a recess in the wing surface in which to mount the outer struts.

(a.) Glue a WA part onto each of four standard W4 ribs. **IMPORTANT NOTE:** All four of the assemblies are different. There is an upper right, lower right, upper left and lower left. Check with the plan to insure that you assemble the parts in correct sequence. WA is on the upper part of the bottom wing ribs and on the lower part of the top wing ribs.

(b.) Cut a slot into W5 with a new, sharp knife or razor blade to pass brass part ST. Be careful not to cut too deeply. Follow the construction layout shown below and put the notch in toward WA. Don't get glue into the notch. Leave ST out until the wing is completely assembled and ready for covering.

(c.) Glue W5 on WA, lining it up exactly with the W4 rib or W2 rib.

USE W2 OR W4 BASE RIB TO GLUE WA TO, DEPENDING ON AILERON CONFIGURATION USED.

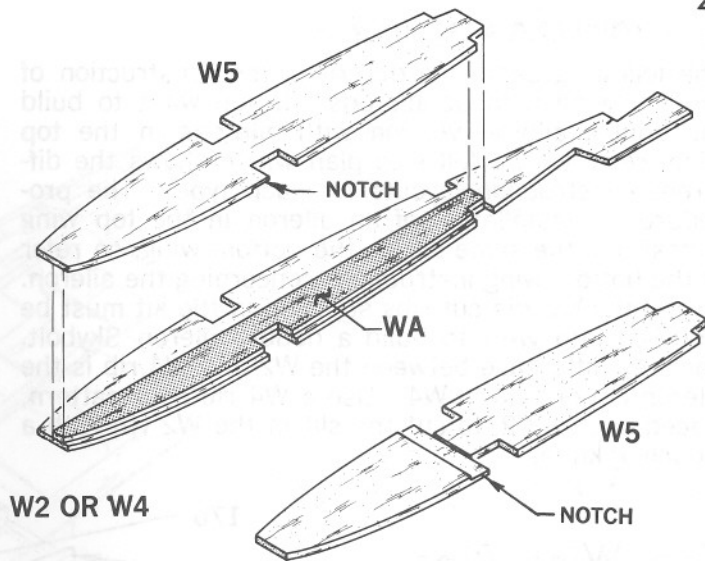

GLUE NOTCHED SIDE OF W5 RIBS IN, TOWARD WA. DON'T GET GLUE INTO NOTCH.

Outer Strut Rib Assembly

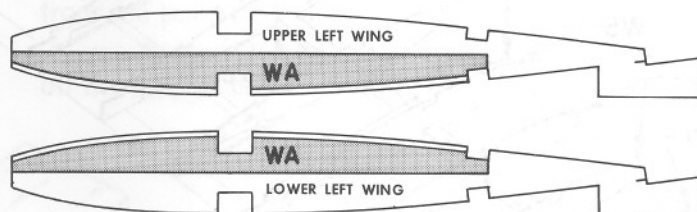
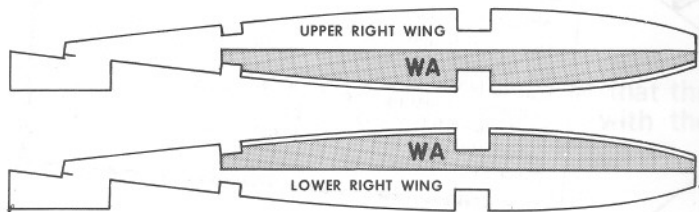

(16.) WING TIPS

The laminated outline used on the wing tips is not difficult and produces a strong and warp resistant unit. Make the tips and remove them from the plan before beginning construction of the rest of the wing. Use only Sig Bond glue for best results on the wet wood.

Laminating The Wing Tips

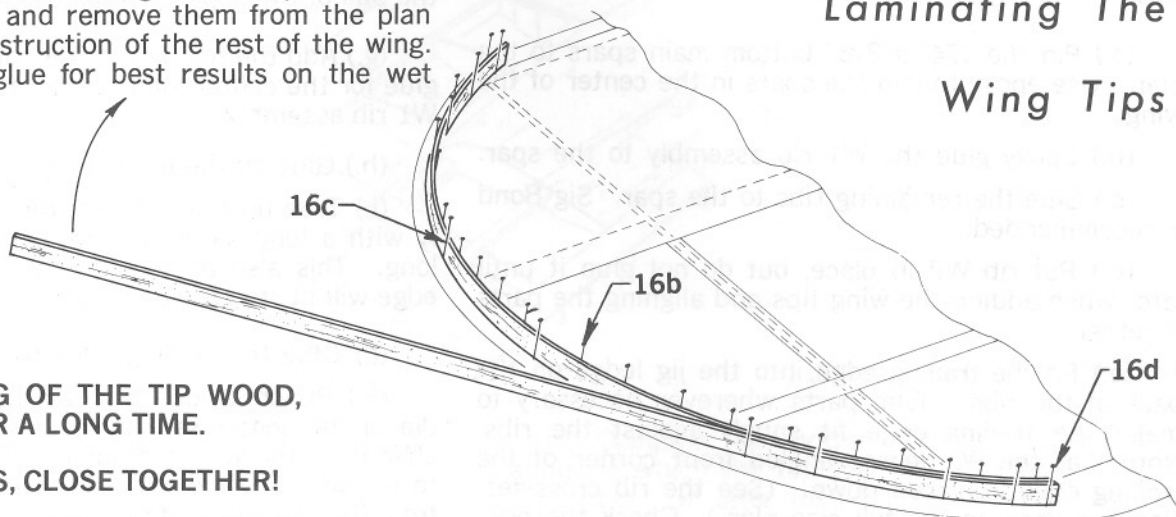

FOR EASY BENDING OF THE TIP WOOD, SOAK IN WATER FOR A LONG TIME.

USE PLENTY OF PINS, CLOSE TOGETHER!

(a.) Soak 1/16" x 1/4" balsa strips for at least an hour to soften them.

(b.) Place pins along the inside of the tip outline on the plan.

(c.) Pin a strip of 1/16" x 1/4" balsa against the first line of pins, holding it in place with a second line of pins.

(d.) As the second strip is laminated against the first, remove the second line of pins one by one as you proceed along the tip and move them over to secure the second strip against the first.

(e.) Continue the process described in (d.) above until all four strips are joined. Allow to dry thoroughly before removing from the board.

(17.) TOP WING ASSEMBLY

The following sequence describes the construction of the top wing without ailerons. If you want to build the double aileron version with ailerons in the top wing, refer to the full size plan which shows the different construction layouts for each type. The procedure for installation of an aileron in the top wing is basically the same as for the bottom wing, so refer to the bottom wing instructions concerning the aileron. Two of the W2 die cut ribs supplied in the kit must be modified into W4's to build a double aileron Skybolt. The only difference between the W2 and W4 rib is the aileron cut-out slit in W4. Use a W4 rib as a pattern, placed over a W2, to cut the slit in the W2 rib with a modeling knife.

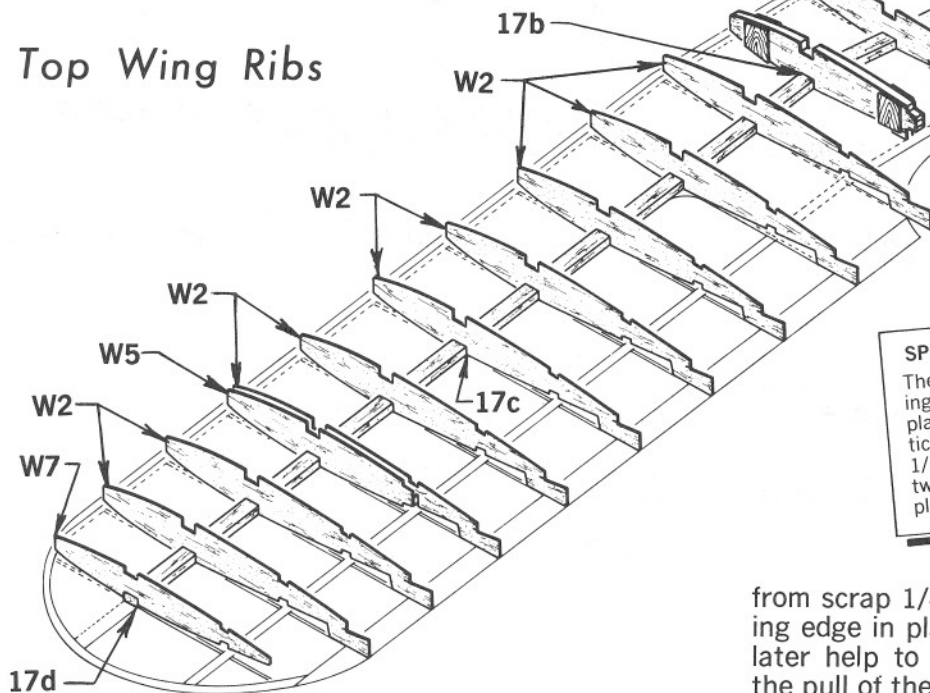
Top Wing Ribs**SPECIAL NOTE:**

The wing design assumes use of a doped cloth covering which adds tension strength. If you plan to use plastic film coverings, higher powered engines or anticipate subjecting the model to unusual strain, add 1/8" sheet fill-in wood to the fronts of the spars, between the ribs, out to the second rib outboard of the planked center section.

(a.) Pin the 1/4" x 3/8" bottom main spars to the plan. Use epoxy to join the spars in the center of the wing.

(b.) Epoxy glue the W1 rib assembly to the spar.

(c.) Glue the remaining ribs to the spar. Sig Bond is recommended.

(d.) Put rib W7 in place, but do not glue it until later when adding the wing tips and aligning the parts together.

(e.) Fit the trailing edge into the jig ledge on the back of the ribs. Trim parts wherever necessary to make the trailing edge fit snugly against the ribs. Note that the 90 degree angled front corner of the trailing edge is placed down. (See the rib cross-section drawings on the full size plan.) Check the position of the 1/16" x 3/16" cap strips and center section planking on the ribs in relation to the trailing edge to be certain the trailing edge is positioned correctly on the ribs.

(f.) Since there will be minimum gluing contact between the ribs and the trailing edge until the cap strips are installed, add some small gussets, made

Before beginning construction of the wing frames, the laminated wing tips should be made and removed from the board. Also complete the W1 and W5 rib assemblies for installation in the wing structure.

from scrap 1/8" sheet, at each rib to secure the trailing edge in place. Leave the gussets there - they will later help to keep the trailing edge from yielding to the pull of the doped covering when shrinking.

(g.) Add the top 1/4" x 3/8" main spar. Use epoxy glue for the center joint and to attach the spar to the W1 rib assembly.

(h.) Glue on the top rear spars.

(i.) True up the fronts of the ribs by sanding lightly with a long sanding block, preferably at least 24" long. This also angles the rib fronts so the leading edge will fit snugly against them.

(j.) Glue the leading edge to the front of the ribs.

(k.) Punch or drill a 1/16" hole through the middle of the center section leading edge into the inner channel of the W1 rib assembly. This is to pass a wire to punch the dowel out when removing the top wing from the cabane struts.

(l.) Fit the laminated wing tip and glue the rib onto the wing. Hold it in place with pins and scrap scabs of wood underneath. Glue to the leading and trailing edge first.

(m.) Fit rib W7 against the tip and glue the rib to the tip and to the spars. The rear spar must be bent down to the tip. Wetting it will help it bow into place.

(n.) Add the short section of 1/4" x 3/8" spar stock between the spar and the tip.

(o.) Taper the main spar between W7 and W2 (or W4 on a top wing with ailerons).

(p.) Trim and sand the top of the leading edge to shape. (See the rib cross-section drawings.)

TOP WING IS FLAT - NO DIHEDRAL

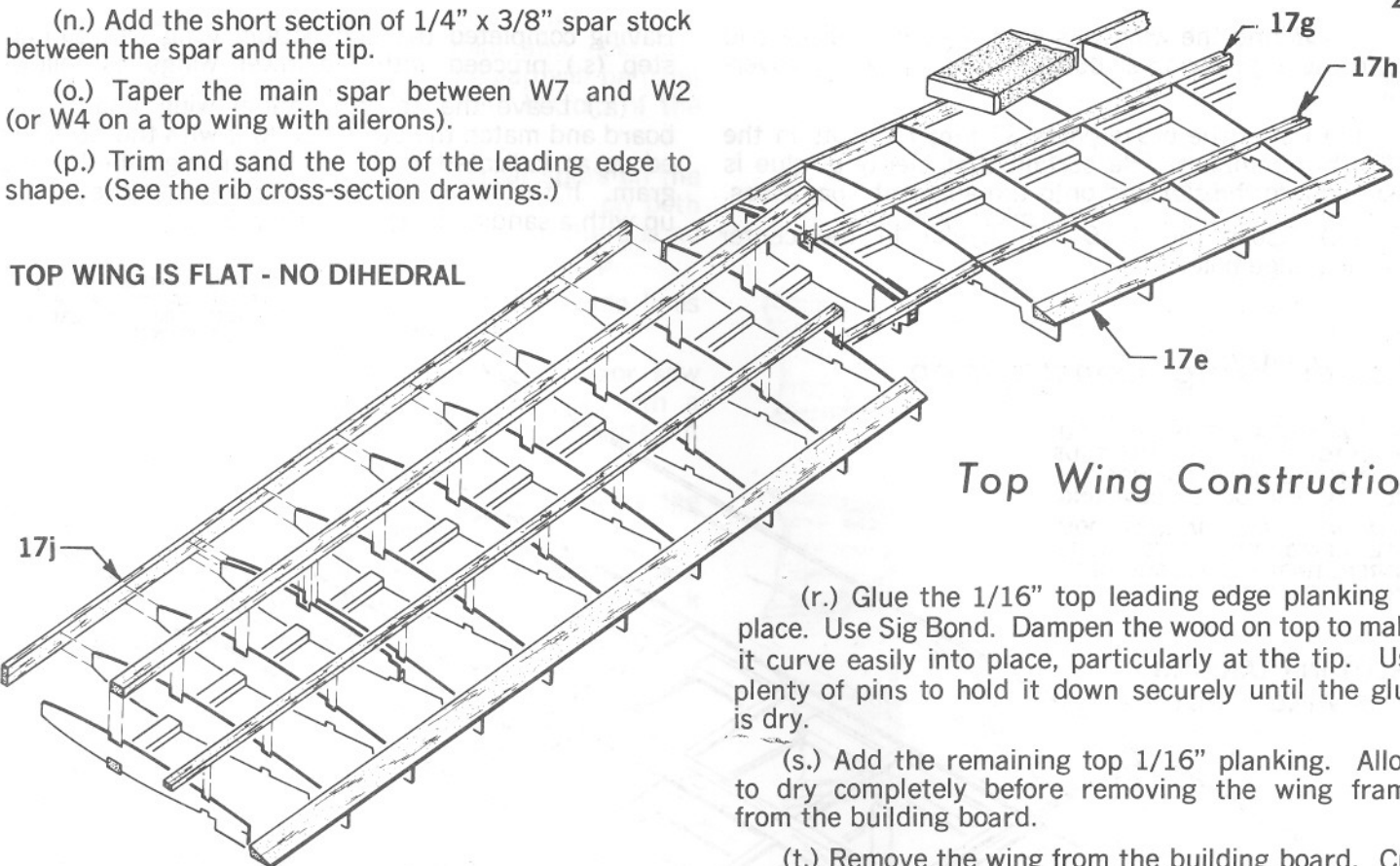

Top Wing Construction

(r.) Glue the 1/16" top leading edge planking in place. Use Sig Bond. Dampen the wood on top to make it curve easily into place, particularly at the tip. Use plenty of pins to hold it down securely until the glue is dry.

(s.) Add the remaining top 1/16" planking. Allow to dry completely before removing the wing frame from the building board.

(t.) Remove the wing from the building board. Cut off the jig portions of the Ribs.

(q.) Notch into the laminated wing tips so that the surface of the 1/16" planking will be flush with the rest of the tip.

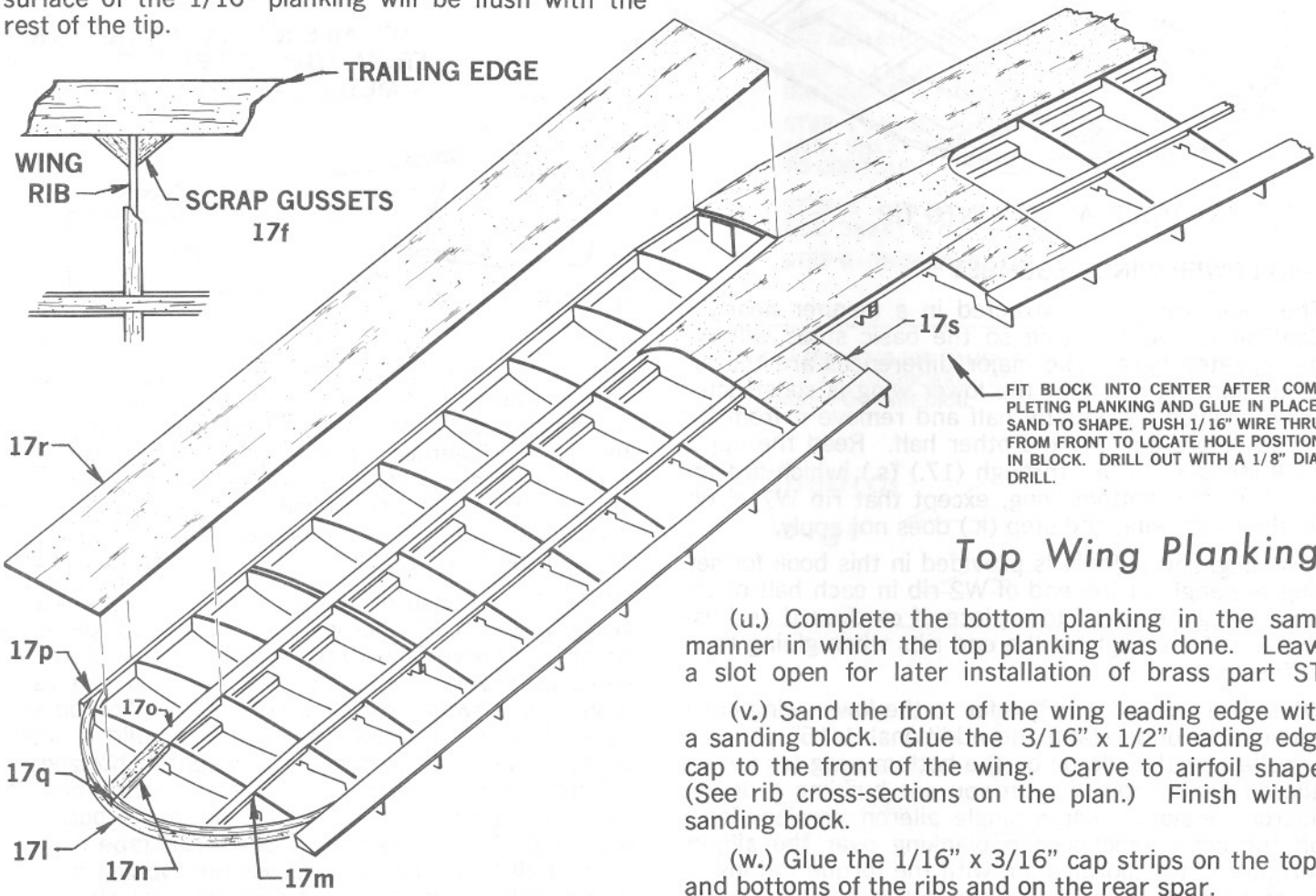
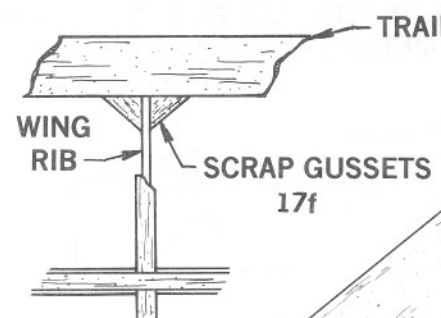

Top Wing Planking

(u.) Complete the bottom planking in the same manner in which the top planking was done. Leave a slot open for later installation of brass part ST.

(v.) Sand the front of the wing leading edge with a sanding block. Glue the 3/16" x 1/2" leading edge cap to the front of the wing. Carve to airfoil shape. (See rib cross-sections on the plan.) Finish with a sanding block.

(w.) Glue the 1/16" x 3/16" cap strips on the tops and bottoms of the ribs and on the rear spar.

(x.) Round the wing tips with a sanding block and sand the entire wing smooth in preparation for covering.

(y.) Epoxy the brass parts ST into the slots in the W5 rib assemblies. Be certain that plenty of glue is worked into the slot and onto the adjacent spar areas.

(z.) Epoxy the 1/16" I.D. Eyelet in the center leading edge hole.

Lower Wing Construction

W3, W6 AND W8 RIBS ARE DOUBLED TO STRENGTHEN THE ENDS OF THE AILERONS AGAINST THE PULL OF THE DOPED COVERING.

W3A, W7A AND W9A RIBS DOUBLE THE W3, W7 AND W9 RIBS TO STRENGTHEN THE AILERON OPENINGS IN THE WING.

SLOT IN PLANKING FOR WING STRUT

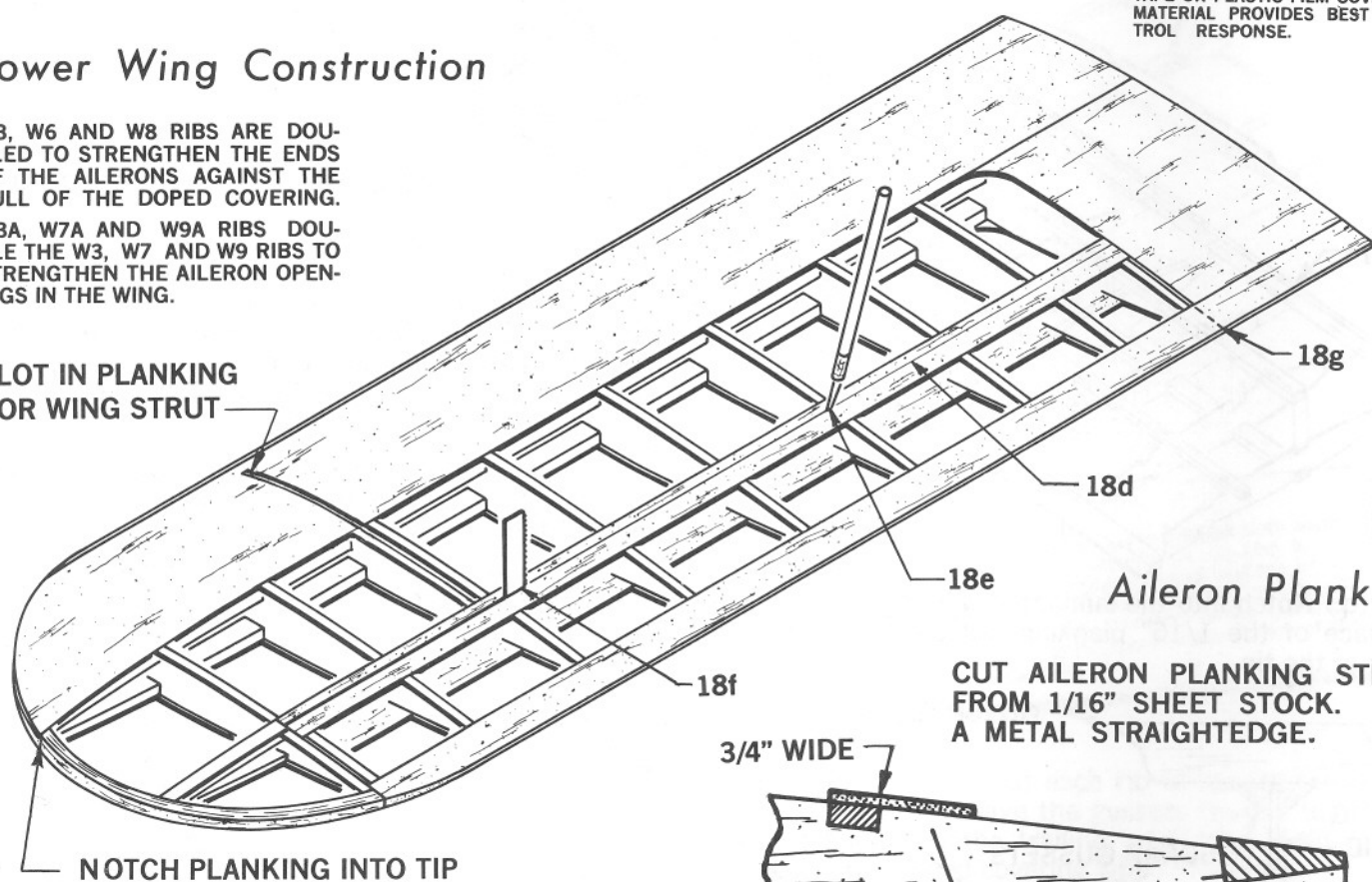

NOTCH PLANKING INTO TIP

(18.) LOWER WING ASSEMBLY

The lower wing is constructed in a manner nearly identical to the top wing so the basic steps will not be repeated here. The major differences are the ailerons and the fact that the lower wing is constructed in two halves. Make one half and remove it from the board before building the other half. Read the upper wing steps (17.) (a.) through (17.) (s.), which are the same for the bottom wing, except that rib W7 is W9 on the lower wing and step (k.) does not apply.

A small gauge pattern is provided in this book for setting the angle of the end of W2 rib in each half of the lower wing. Paste it to a piece of cardboard and use this to set the angle of the end ribs when gluing them to the spar.

When you read step (s.), refer to the lower wing cross sections to understand the additional 1/16" planking required for the aileron on the bottom wing (or for the aileron on the top wing, if you are building a double aileron version). For a single aileron version, leave off the center section top planking over the aileron torque rod for coordination with the torque rod installation as is explained further on in this section.

Having completed the 2nd bottom wing half through step (s.) proceed with the lower wings as follows:

(a.) Leave the second bottom wing half on the board and match the other half to it with the tip blocked up as indicated in the accompanying dihedral diagram. If the halves do not fit snugly together, touch up with a sanding block until they do.

SEALING CONTROL GAPS WITH TAPE OR PLASTIC FILM COVERING MATERIAL PROVIDES BEST CONTROL RESPONSE.

Aileron Planking

CUT AILERON PLANKING STRIPS FROM 1/16" SHEET STOCK. USE A METAL STRAIGHTEDGE.

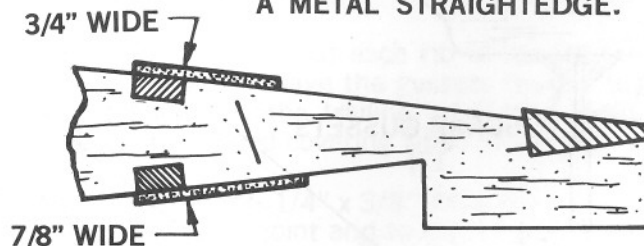

(b.) Punch some 1/16" diameter holes at a slight angle into the ends of the spars, leading and trailing edges. Carefully spread epoxy glue into these, working out any air lock. Also glue the rib faces and join the two halves together. The glue in the punched holes will "nail" the parts together and make the joints stronger than the wood itself. When the glue cures, remove the wing from the board. Cut off the jig portions of the ribs.

NOTE: In the case of use of a miniature size aileron servo and single ailerons, the hardwood piece on which the servo is mounted (see full size plan) will serve as a very adequate joint splice. If you use a larger servo (which will be screwed to a plywood scab epoxied on top of the spars) or if you build a double aileron version (with the servo mounted horizontally behind the main spars), epoxy some scrap plywood across the spar joints before closing in the bottom of the wing. Also epoxy a strip of aircraft tape or fiberglass cloth (not furnished) across the top center seam of the bottom wing and coat it generously with epoxy.