



MESSERSCHMITT

Bf-109

ALMOST READY TO FLY
A High Performance Electric Powered Warbird!

ASSEMBLY MANUAL



KIT NO. SIGRC102ARF



SIG MANUFACTURING COMPANY, INC.



MESSERSCHMITT
Bf-109 *ALMOST READY TO FLY*
A High Performance Electric Powered Warbird!



Messerschmitt Bf-109 ARF ASSEMBLY MANUAL

INTRODUCTION:

The prototype, Messerschmitt Model 109, first took to the air in mid-September of 1935 and its performance was nothing short of spectacular! Small, powerful, and fast, Willy Messerschmitt's Model 109 surely had a date with destiny.

Based on many of the design concepts of the earlier Model 108 *Taifun*, the Model 109 was exceptionally well constructed and aerodynamically clean. The concept behind the 109 was to place the smallest and cleanest airframe possible behind the most powerful engine available at the time. This resulted in an aircraft that had many positive attributes, as well as a few negatives. One of these negatives was the weight of the airplane versus its relatively small wing. This created a high wing loading, especially in comparison to its eventual foes. In an attempt to keep the weight as low as possible, the retractable landing gear pivoted outward toward the wingtips, keeping the main wing spar weight down. But as a result, the splayed, close-tracked landing gear would plague the design for the rest of its operational life. All of this aside, the Model 109 can truly be called one of the first modern fighter aircraft of the era.

The Bf-109 was ultimately manufactured in greater numbers than any other aircraft in history - over 30,000 units between 1939 and 1945. It was manufactured in Germany, Czechoslovakia, and Spain. To keep the airplane competitive in combat, it went through many modifications and remained the Luftwaffe's primary fighter aircraft throughout WWII. Used in a wide variety of combat missions, the Bf-109 served as an air superiority fighter, a bomber escort, an interceptor, a ground attack aircraft, and in high-speed reconnaissance missions. But in its primary role as an air superiority fighter, the Bf-109 was truly a formidable aircraft. In fact, at one time or another, every top scoring German fighter ace flew Bf-109's. Notably, Erich Hartmann, with a combat record of 352 enemy aircraft shot down, always flew a Bf-109, refusing to fly any other aircraft.

In historical terms, the Bf-109 will *always* be best remembered for its role in the Battle of Britain, forever being compared to its closest adversary of the time, the Supermarine Spitfire. While these comparisons rage on to this day, it's fair to say that both of these fine aircraft were among the best of their day.

The SIG Messerschmitt Bf-109 ARF is a sport scale model, not necessarily based on any particular full-scale variant. The covering is printed with color and markings representing typical German aircraft of the era, including details such as panel lines and national markings. The builder can add unit markings and other details of his own choice to make a convincing replica of this great German warplane.

The recent and rapid development of super-efficient brushless electric motors and lithium polymer batteries have made electric powered aircraft, such as the Bf-109, a practical reality. Our prototype Bf-109 models have proven to be outstanding R/C aircraft, both in terms of looks and performance. We have flown our own prototypes a great deal and can report that they are solid flying models with honest flight characteristics. When powered with an appropriately sized brushless outrunner motor swinging the recommended propeller, the airplane will have a wide speed range and be capable of some very nice scale fighter plane type aerobatics. While the SIG Bf-109 ARF is a comfortable model to fly, we do not recommend it for a first R/C model. But we can and do recommend the Bf-109 as your first electric warbird.

This assembly manual will guide you through each assembly step in detail and is further enhanced with photos that visually assist you with each step. It is important that you follow the provided construction sequence to achieve the best results.

Reference Material:

SIG Manufacturing Company, Inc. wishes to gratefully acknowledge the excellent reference materials listed below:

- [http://en.wikipedia.org/wiki/Messerschmitt Bf 109](http://en.wikipedia.org/wiki/Messerschmitt_Bf_109)
- <http://www.axishistory.com/index.php?id=1154>
- "*The Great Planes*", by James Gilbert, Published by Grosset & Dunlap, 1970

Specifications:

	Imperial	Metric
Wing Span:	48 in.	1219 mm
Wing Area:	396 sq. in.	25.52 dm ²
Length:	42.5 in.	1079 mm
Flying Weight:	60 oz.	1700 g
Wing Loading:	21.8 oz./sq. ft.	66.6 g/dm ²
Motor:	Brushless, 300 to 400 watt	
ESC Required:	Brushless type to suit motor & battery pack	
Battery Pack Required:	3-Stack 3300 mAh Lithium Polymer Pack Typical	
Radio Required:	4 Channel w/ Hitec 2-HS55 and 2-HS81 servos or equivalent	
Order Number:	SIGRC102ARF	

ITEMS REQUIRED TO COMPLETE THIS KIT:

- Radio System - 4-channels, with 4 micro servos (Hitec HS-55 & HS-81 used & shown in this manual)
- Appropriate servo extensions (see Radio Systems section for specifics)
- Brushless Motor (see Power System section for recommendations)
- Brushless Speed Control (see Power System section for recommendations)
- Lithium Polymer Battery Pack (see Power System section for recommendations)
- Propeller (see Power System section for recommendations)
- Motor mounting bolts, sized for your particular motor
- Dremel® Tool with a variety of sanding bits
- An assortment of screwdrivers

- Pliers - needle nose and flat nose types
- Wire cutters
- A selection of glues - thin, medium, and thick SIG CA, SIG Epoxy Glue (5 and 30 minute types) and SIG Super-Weld white glue
- Fine point CA applicator tips
- Drill with assorted small drill bits
- Pin vise for small diameter drill bits
- Small T-pins
- Sandpaper
- Hobby knife with sharp #11 blades
- Scissors
- Covering iron and trim seal tool
- Paper towels

RADIO SYSTEMS:

The SIG Bf-109 ARF requires the use of a four-channel radio system and four micro servos. Due to limited space in the wing bays for aileron servos, we used and can recommend the Hitec HS-55 (2 required) for this purpose. We used and can recommend Hitec HS-81 servo for the fuselage-mounted elevator and rudder servos. These little servos fit into the fuselage tray perfectly and provide plenty of torque. A sub micro receiver is not mandatory but smaller receivers like the Hitec Electron 6 do offer great reliability and considerably lighter weight over larger, standard type receivers.

Servo Extensions: In order to connect the ailerons servos to the receiver, two 6" servo extensions and one standard Y-harness will be required. Note that in our radio installation, we leave the "Y" harness plugged into the receiver, plugging the two aileron servo extensions into it whenever the wing is attached.

POWER SYSTEMS:

Motors: The Bf-109 has been designed to fly with brushless motors in the 300 to 400 watt range. We have used and can certainly recommend the fine Himax range of brushless motors for your own Bf-109 model. We have tested this airplane with both the Himax #HC3516-1130 (300 watt) and HC3522-0990 (400 watt) brushless motors with great results.

Electronic Speed Controls (ESC): We suggest using a 35 amp ESC for 300 watt motors or a 45 amp ESC for 400 watt motors.

Propellers: We suggest using an APC 10 x 7E propeller with either the 300 or 400 watt motors or an APC 11 x 7E, used only with the 400 watt motor

Battery Packs: We suggest using a 3S 3300 mAh Lithium Polymer battery pack. Note that this pack fits perfectly in the Bf-109 battery tray.

Battery Charger: ***Use a charger designed specifically for lithium polymer batteries! Using any other type of battery charger for lithium polymer batteries can be extremely dangerous.***

COVERING MATERIAL:

The Bf-109 ARF has been professionally covered in SIG AEROKOTE® iron-on plastic covering material. This covering is a tough, lightweight, and heat shrinkable material. The camouflage patterns, national markings, and other detail and panel lines have been printed on the outer surface of the covering, giving a very

realistic overall look to the model. The inks used in the printing process are quite durable and bond to the covering film extremely well. Normal handling and flying conditions should have little, if any effect on the printed finish. However, carefully note that certain solvents can and will soften the ink, allowing it to be rubbed off. The following is a short list of cleaners and solvents that can and cannot be used on the printed finish of your model:

<u>Use</u>	<u>Do Not Use</u>
Windex® Window Cleaner	CA Debonder
SIG Model Magic Cleaner	Acetone
Hexane	Alcohol
	Dope Thinner

If in doubt of the suitability of a cleaner or chemical to use on your model, always test it first, choosing an inconspicuous location on the model. In addition to the above, carefully note that excessive heat from typical covering tools, such as heat guns, covering irons and trim seal tools, may also soften and remove the ink finish. Work only with temperatures set at 250° F or less. Whenever working on the covering with a heat iron, we strongly suggest that you first cover the shoe of the iron with a soft cotton cloth, such as an old T-shirt.

Your Bf-109 ARF kit was built and covered in a part of the world that has a great deal of humidity. You may therefore notice that after the covered parts have been removed from their plastic bags, that some wrinkles may appear after 24 to 48 hours. This is perfectly normal and is the result of the wood losing humidity and dimensionally shrinking.

If wrinkles appear in the covering, they are easy to remove, using a little heat. Because of the ink printing, it is not advisable to rub a hot iron over the surfaces to be tightened. If proper precautions are taken, a heat gun will do the job quickly. First, locate and inspect all the seams where the covering overlaps like at the leading and trailing edges of the wing and tail surfaces and the top and bottom of the fuselage. Seal these overlaps down with a trim iron (set to about 220°F to 240°F) by applying the iron to the seam overlap for a few seconds without moving the iron, then lift the iron to move to the next location and repeat. Do this until you are sure that all the seams are secure before proceeding with the heat gun. Protect these seams with wet paper towel strips while you shrink the loose areas with the heat gun. Use caution to never use any more heat than necessary to get the covering to shrink.

COMPLETE KIT PARTS LIST:

The following is a complete list of all parts contained in this kit. Before beginning assembly, we suggest that you take the time to inventory the parts in your kit, using the provided check-off boxes (☐). Carefully note that the CA type hinges for the rudder, elevators, and ailerons are in place in their appropriate locations but are not glued in place. All parts are covered in pre-printed AeroKote® with green and blue-gray camouflage colors with panel lines and other details except where noted.

- ☐ Bag #1 Vertical fin and rudder, 2 CA hinges installed but not glued, leading edge of rudder at the bottom drilled and routed to receive the tail wheel wire.
- ☐ Bag #2 Stabilizer and elevator, 4 CA hinges installed but not glued, elevator joiner wire installed but not glued.

- Bag #3 Full Span Wing, ailerons installed with 3 CA hinges on each but not glued, aileron servo hatches installed with 4 ea T2 x 6 mm PWA screws
 - 2 ea. T2 x 8 mm PWA screws
 - 2 ea. 3 mm ID x 6 mm silicone tube keepers
- Bag #4 Fuselage with top hatch/cockpit installed and retained by magnets, motor mount/battery tray installed, two plastic pushrod tubes installed, blind nuts for wing hold down bolts installed, servo tray installed.
- Bag #5 Clear Canopy with frame painted on, 4 holes drilled for mounting screws.
 - Sub bag 4 ea. T2 x 6 mm PWA screws
- Bag #6 Fiberglass cowl - painted yellow.
 - Sub bag 4 ea. T2 x 12 mm PWA screws
- Bag #7 Wire Pushrod bag
 - 2 ea. 1.25 mm dia. x 597 mm with "Z" bend on one end
 - 2 ea. 1.25 mm dia. x 98 mm with "Z" bend on one end
- Bag #8 Tail Wheel Assembly with 25 mm dia. Wheel
- Bag #9 Green covering material for repairs, 2 ea. 110 mm x 30 mm
- Bag #10 Control Horn bag
 - 4 ea. Control horns
 - 4 ea. Backing plates
 - 4 ea. Pushrod connectors with set screws
 - 4 ea. Metal keeper washers
 - 8 ea. M2 x 20 mm bolts
- Bag #11 Accessory Bag with 2 ea. Plywood landing gear doors painted gray, drilled for mounting bolts and air scoop for fuselage.
 - Sub bag
 - 4 ea. Metal straps to retain landing gear doors
 - 8 ea. M2 x 8 mm bolts
 - 8 ea. M2 nuts
 - 8 ea. M2 washers
- Bag #12
 - 2 ea. plywood washers, 24 mm dia. - painted gray one side.
 - 2 ea. M4 x 30 mm plastic wing hold down bolts
- Bag #13 Spinner Bag with yellow painted plastic spinner cone
 - 1 ea. 72 mm dia. x 4.5 mm plywood backplate
 - 2 ea. 20 mm dia. x 2mm plywood washers for spacers
- Bag #14
 - 2 ea. Painted plastic wing radiator covers
- Bag #15
 - 4 ea. 8 mm square x 12 mm hardwood for wing servo mounts
- Bag #16 Tail Brace Bag - all parts painted gray
 - 2 ea. 2 mm dia. x 94 mm wire threaded M2 on one end and an eyelet bent on the opposite end
 - 2 ea. M2 R/C metal R/C links
 - 2 ea. M2 knurled lock nuts
 - Sub bag
 - 2 ea. Metal tabs, drilled two places and bent in center
 - 2 ea. T2 x 6 mm PWA screws
- Bag #17 Main Landing Gear Bag
 - 2 ea. 4 mm dia. Wire landing gear wires - pre-bent
 - 2 ea. 63 mm dia. Light foam wheels
 - Sub bag
 - 4 ea. Plastic retaining straps
 - 8 ea. T3 x 8 mm PWA screws
 - 2 ea. 4.1 mm ID wheel collars with set screws
 - 2 ea. 4 mm ID plastic bushings

NOTE: In this manual, all references to "right" or "left" refer to your right or left, as if you were seated in the cockpit looking forward.

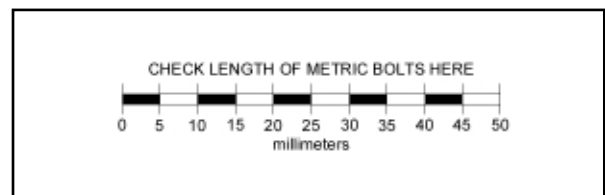

WING ASSEMBLY:

The following parts will be required for this assembly sequence:

- Wing
 - 4 ea. servo mounting blocks from Bag 15
 - 2 ea. Hitec HS-55 or similar sized aileron servos - not included
 - 2 ea. 6" servo wire extensions - not included
- Bag #10
 - 2 ea. Control horns
 - 2 ea. Backing plates
 - 2 ea. Pushrod connectors with set screws
 - 2 ea. Metal keepers,
 - 4 ea. M2 x 20 mm bolts
- Bag #12
 - 2 ea. Painted plywood wing bolt washers
 - 2 ea. M4 x 30 mm nylon wing bolts
- Bag #7
 - 2 ea. .048 x 3-7/8 (98 mm) wire pushrods with Z-bend
- Bag #11
 - 2 ea. Landing gear doors with hardware
- Bag #14
 - Radiator covers
- Bag #17
 - Landing gear wires with mounting hardware

1) As noted above, the hinges for the ailerons are not yet glued. The first step is to remove the left and right ailerons and the hinges from the wing. The hinges have a die-cut center slot that can be used to accurately place and center the hinge equally into

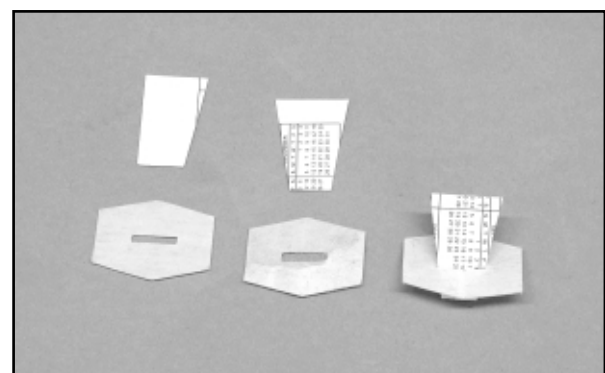

can be used to accurately place and center the hinge equally into both the wing panel and the aileron. To do this, use a business card and a pair of scissors to cut some "wedges". These should be wide enough at the top so as to not pass through the hinge slot cut-out. Insert each hinge in place into the wing panel up to the cardboard wedge.

Now, slip the aileron onto each hinge, pressing it fully in place. Center the aileron, leaving equal spacing between each end of the aileron and the wing.

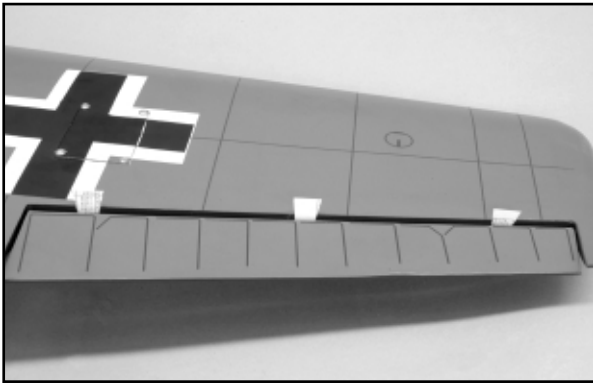

Important Note: When installing CA type hinges, *more is not better!* Applying excess thin CA glue to this type of hinge does nothing more than stiffen it, potentially causing the hinge to crack and break. If you have followed these instructions, each hinge will have a total of 6 small drops of thin CA glue on each side. This is the correct amount of adhesive for the purpose. Using a fine tip applicator for this purpose is strongly advised and recommended.

□ 2) Flex the aileron down a 1/2" or so to expose the center of the hinge and use a piece of masking tape to hold it in this position. Remove the wedge from one of the hinges and apply three drops of thin CA to each exposed side of the hinge. Repeat this operation until all the hinges on this side of the wing are glued.

IMPORTANT: - Be careful to avoid getting glue on the covering. Solvents such as CA debonder will also remove the ink on the covering.

□ 3) Remove the tape holding the flexed aileron, returning it to the neutral position. Turn the wing over and flex the aileron down about 1/2", again exposing the center of the hinges. Use another piece of tape to hold the aileron in this position. Repeat the same gluing process on each hinge - 3 small drops of thin CA on each exposed side of each hinge. Remove the tape holding the aileron and return it to the neutral position. Hold the wing up to the light and look through the gap between the aileron and the wing for any excess glue that may have accumulated in the gap. Inserting a slip of paper into the hinge gap, on each side of the hinges, will wick out any excess CA glue. Hinge the opposite aileron using the same procedure.

Note that it typically takes a little time for CA glue to fully "wick" its way across the surface of the hinge and surrounding wood. Allow about 10 minutes or so before flexing the ailerons. After sufficient time has passed, firmly flex each aileron briskly up and down to

create free and easy movement. We also suggest pulling on the aileron at each hinge location, making sure each hinge is firmly in place.

□ 4) Remove the four screws from each corner of both aileron servo covers on the bottom of the wing. With the aileron servo covers out of the way, remove the covering from the slot that has been cut for the servo arms.

□ 5) Install straight servo arms onto two HS-55 servos, orienting the arms at 90° to the servo body. Note that these extra arms come with the servos and are about 1-7/32" long, end to end.

□ 6) Lay the servo onto the inside surface of the aileron hatch, positioning the servo arm centered in the slot, with the servo body within the borders of the hatch. Hold the servo in this position and use a pencil to mark where the bottom of the servo mounting lugs and sides of the servo case meet. This marks position of the two wooden servo mounts.

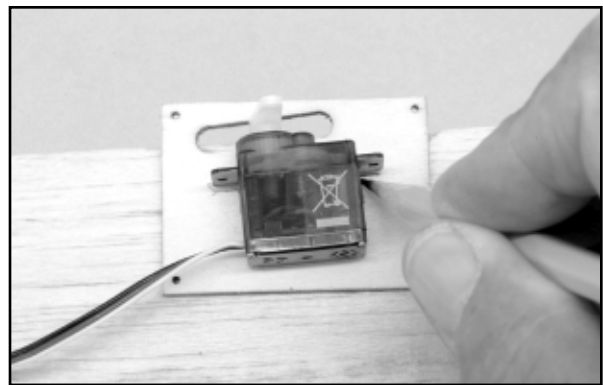

□ 7) Locate the four 8 mm square x 12 mm long hardwood blocks from bag #15. These are glued on end, to the servo hatch, at the location marks just made. 5-minute epoxy or thick CA glue works well for this purpose. Allow the glue to fully set.

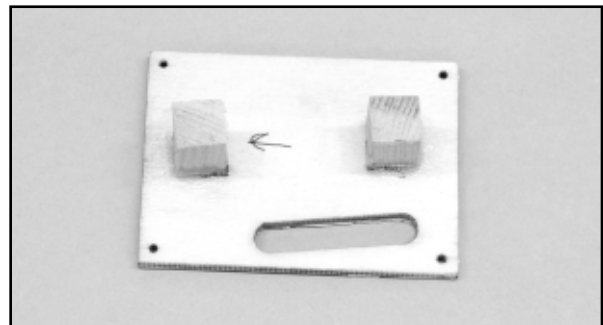

□ 8) Place the servo back onto the hatch between the two mounting blocks. Use a sharp pencil to mark the servo mounting

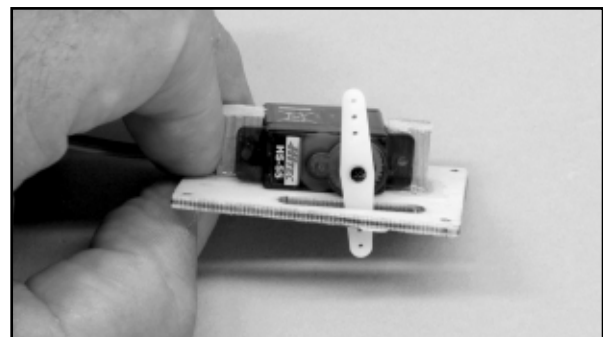

hole locations onto the mounting blocks.

Remove the servo and drill pilot holes for the servo mounting screws into the wood mounting blocks, using a #60 (1 mm) bit. Use the mounting screws that came with your servo to secure the servo to the mounting blocks.

Repeat this same procedure with the remaining aileron servo and servo hatch.

□ 9) In this step, the servo arms will be centered onto the servo output shaft. First, remove the servo output arm retaining screws and remove the servo output arms. Connect the two aileron servo leads into a standard "Y" harness. Plug the "Y" harness into the receiver. Turn your transmitter on and center the aileron trim to neutral. Connect the receiver to a 4.8v battery pack. With the system now on and working, reattach the two servo output arms onto the two aileron servos, with the arms at 90° (or as close to 90° as possible) and reinstall the output arm retaining screws into each servo. If your radio system has "sub trim" capability, use this feature to further center the output arms at 90° to the servo body and centered within the servo hatch slot. Once the output arms are both centered, cut off the opposite, unused end of each arm. This ensures that the arm will not contact the covering on the inside top of the wing when the servo tray is installed. Turn the radio system off and unplug the servo leads from the "Y" harness.

□ 10) Connect a 6" servo lead extension onto each aileron servo lead. We always suggest securing these extensions at the connectors, using a length of heat shrink tubing. This ensures that the connection remains secure.

□ 11) On the top surface of the wing, near the center joint, you will be able to feel the location of two 1/2" diameter holes through the covering. These are the exit holes for the aileron servo leads. Use a sharp #11 blade to remove the covering from these holes. You should then be able to see a small stick tack-glued to the inside top sheeting with a string attached to it. This is the pull string, used to pull the aileron servo leads through the wing ribs.

□ 12) Inside the aileron servo bay in each wing panel, the other end of this string is attached to a small tack-glued stick. Break this stick loose and unwind the string from the stick. This end of the string is secured firmly to the connector end of the servo extension lead (we like to tie this string tightly to the connector). With the string in place to the connector, feed the connector and string into the servo bay while gently pulling on the string at the exit hole in the center of the wing. Start the connector down through the holes in the wing ribs. Lightly pull back and forth until the connector

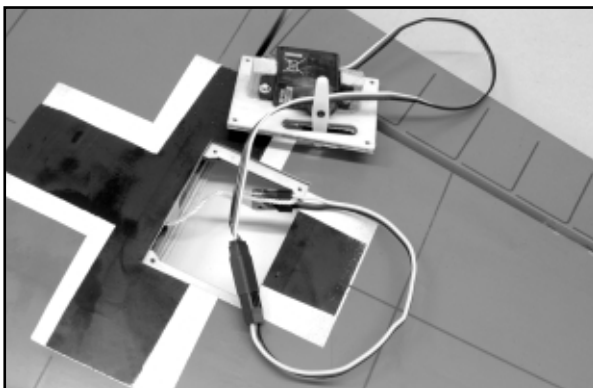

moves through one rib and up to another. Keep doing this until the connector appears at the exit hole. Pull the connector up through the hole and temporarily tape it to the wing surface. Now, mount the servo hatch and servo in place to the bottom of each wing panel, using the provided screws, removed earlier. Repeat this procedure with the opposite servo hatch and wing panel.

□ 13) With both servo leads now through their respective exit holes on the top center of the wing, remove the strings and plug each lead into a standard "Y" harness. Again, we suggest securing these connections with short lengths of heat shrink tubing.

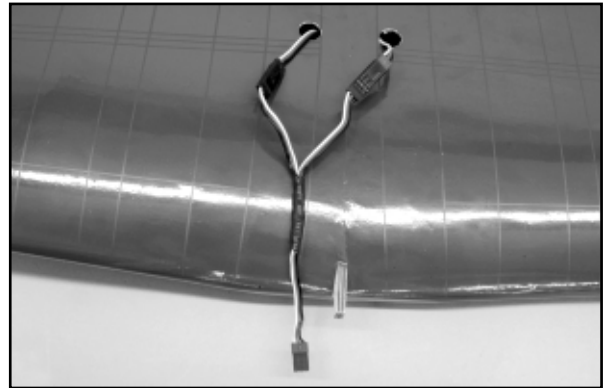

MODELER'S TIP: It happens to all of us now and then; the factory installed servo lead string disappears into the wing! No problem. Simply pull the string completely out of the wing and attach a small weight, such as a metal nut or even a small split shot sinker, to one end of the string. Insert the weighted end of the string into the servo opening and start it down the holes that are just behind the spars. With the wing on end and the center of the wing below the servo well, gently shake the wing while feeding the in the weighted string, listening for the weight to drop through to the next rib. When the center section is reached, turn the wing upside down and shake the weight out of the hole and you're back in business!

□ 14) The aileron control horns are now installed onto the bottom surfaces of each aileron. The vertical center arm of the control horn is located 1-1/2" from the inboard from the end of the aileron, with its four hole locations lined up with the hinge line. Hold the control horn in this position and use a sharp pencil to mark the two control horn mounting hole locations onto the surface of the aileron.

At the two marks just made, use a #46 (2 mm) dia. bit to drill two clearance holes completely through the aileron, 90° perpendicular

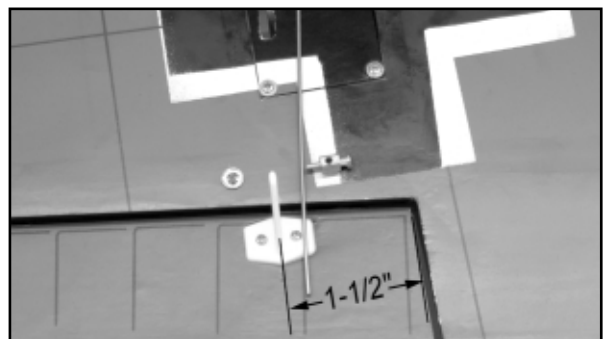

to its bottom surface. Repeat this process on the opposite aileron. Use the four M2 x 20 mm bolts and the two plastic control horn backing plate to now mount each aileron horn to the bottom of each aileron with the backing plates on top of each aileron to engage the bolt ends. Cut off the excess bolt ends and file smooth.

□ 15) Install a pushrod connector, pointing towards the center of the wing, into the outermost hole in the control horn and secure it with a metal keeper washer, pressed in place over the stub end. Repeat this process with the remaining pushrod keeper and keeper washer.

□ 16) Insert the Z-bend end of the .049" dia. x 3-78" (1.25 mm dia. x 98 mm) aileron pushrods into the outermost hole of the aileron servo arms. Note that these holes may need to be slightly enlarged to fit the wire diameter. Slide the opposite, unbent end of the pushrod into the hole in the pushrod keepers on the aileron control horns. Again, connect the aileron "Y" harness into the aileron receptacle in the receiver. Turn the transmitter on and connect a 4.8V battery pack into the receiver. With the aileron servos now working, make sure the trims are at neutral and then tape the ailerons in neutral to the wing. Now firmly tighten the setscrews in the pushrod keepers to lock the pushrods in place. Remove the tape from the ailerons and wing. Move the aileron stick on the transmitter to move the ailerons. Viewed from the rear trailing edge of the wing, the right aileron should move up when the aileron stick is moved to the right. If this aileron movement is wrong, reverse the aileron channel in your transmitter. Once satisfied, disconnect the aileron "Y" harness and battery pack from the receiver and turn off the transmitter.

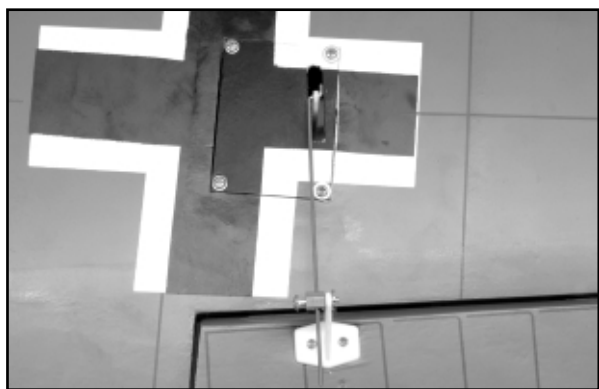

□ 17) The two plastic wing radiator covers (Bag #14) are now glued in place onto the bottom of each wing panel. Notice that there are lines printed chordwise on the bottom covering that are about 3-11/16" (94 mm) out from the center of the wing. A rectangle intersects this line about 4-7/16" (113 mm) forward of the

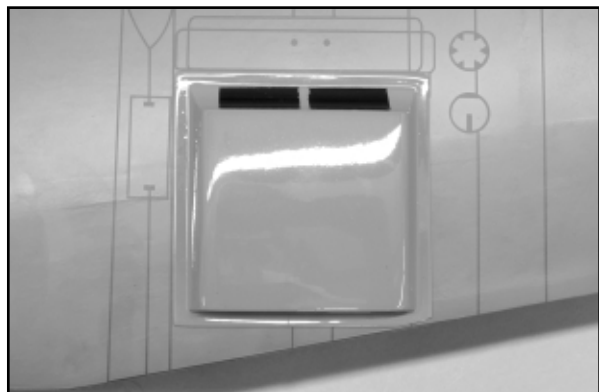

trailing edge. These two lines are used to align the radiators. The black painted inlet side of these covers faces forward towards the leading edge, with the front of the cover even with the rectangle and the inside edge of the cover on the chordwise line. You may need to slightly trim the rear outboard corner of the cover to keep it from hanging over the trailing edge. We suggest using medium or thick CA glue to attach these covers in place, being careful to not use excessive glue that might smear the outer surface of the cover or the covering itself.

□ 18) Use a sharp #11 blade and hobby knife to now open the two wing hold down bolt holes at the trailing edge of the wing center section. Use medium or thick CA glue to glue the two painted plywood washers in place, centered over the two bolt holes in the wing.

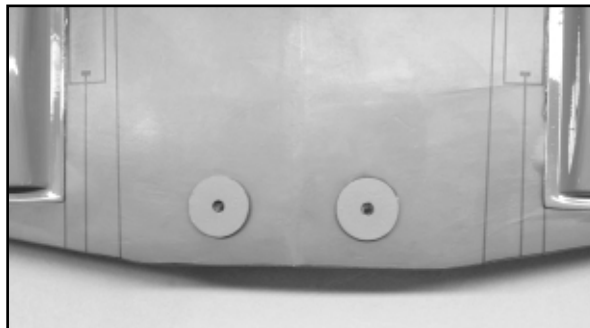

MAIN LANDING GEAR INSTALLATION:

This assembly sequence assumes that the optional main landing gear and related parts will be installed. Note that if you intend to fly your Bf-109 model without landing gear, you can then proceed to the Motor Installation section. The following parts will be required for the following assembly steps.

The parts for the main gear are found in these bags:

- Bag #17: 2 ea. 4 mm wire landing gear legs
2 ea. 63 mm dia. main wheels
4 ea. plastic retaining straps
8 ea. T3 x 8 mm PWA screws
2 ea. 4.1 mm ID wheel collars with setscrews
2 ea. 4 mm ID plastic bushings
- Bag #11: 2 ea. plywood landing gear doors
4 ea. metal straps
8 ea. M2 x 8 mm bolts
8 ea. M2 nuts
8 ea. M2 washers

□ 1) As received, the wing structure includes two slotted hardwood main landing gear mounting blocks, built into the bottom surfaces. These blocks are used to mount and secure the main landing gear wire forms.

On the bottom of the wing center section, about 2-1/4" (57 mm) back from the wing leading edge, you will be able to feel the two slots that will hold the main landing gear legs. Press firmly on these slot locations with your finger, moving back and forth on the surface of the wing until you can see where the edges of these slots are. Once the slots are located, use a sharp #11 blade to carefully slit the covering from one end of the slot to the other. Repeat this with the opposite landing gear slot.

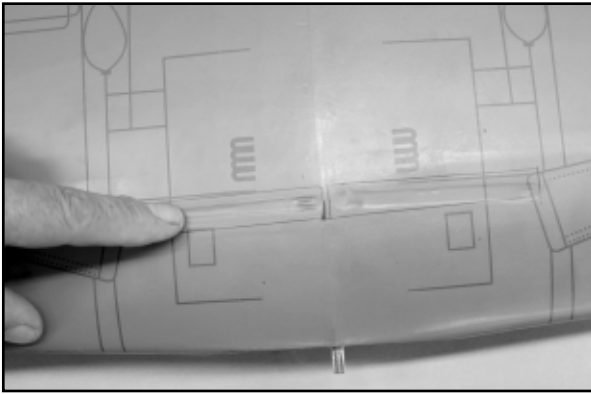

- ❑ 2) Attach the gear doors to the inside of the gear legs using the metal clips, M2 x 8 mm bolts, M2 nuts, and M2 washers. Note that the bottom edges of these doors are made with two distinct angles. The more highly angled edge should be oriented toward the rear of the wing to providing better ground clearance.

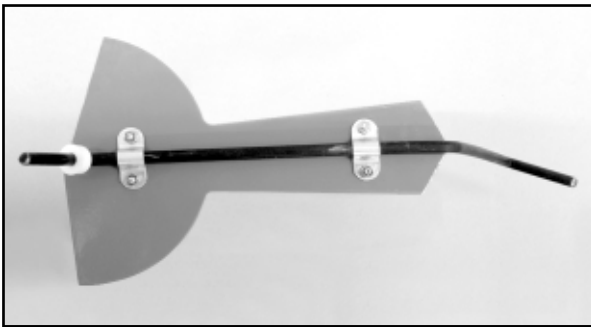

- ❑ 3) Insert the wires into the landing gear blocks in the wing, with the legs and doors offset to the front leading edge of the wing. The wheel axles should be close to the leading edge when viewed from above and aligned with each other in a straight line or a slight toe in position. It might be necessary to slightly "tweek" the axle wires to achieve alignment. If so, do this now.

- ❑ 4) Once satisfied with the axle alignment, secure both landing gear wires into the wing bottom using the four plastic retaining straps, as shown. Hold the strap in place and mark its two hole locations onto the surface of the wing. Use a 3/32" dia. bit to drill pilot holes for the mounting screws. Repeat this process for the remaining landing gear straps. Secure the straps in place with T3 x 8 mm PWA screws.

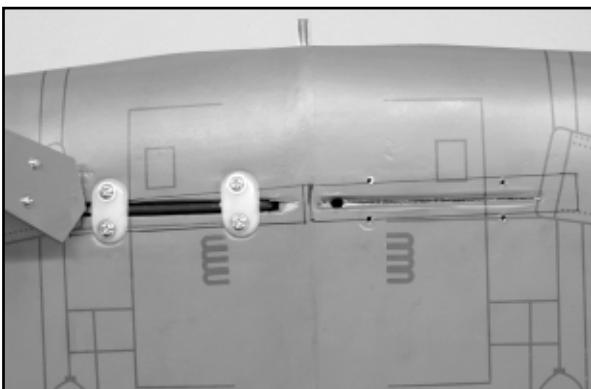

- 5) The main wheels are now installed and secured. Slide a plastic bushing over the axle wire, all the way to the bend. Slide the main wheel in place onto the axle, followed by the wheel collar. The wheel collar should be positioned to allow the wheel to turn

freely with just a small amount of left and right "play". Once in position, firmly tighten the setscrew in the wheel collar. Repeat this process with the remaining wheel.

The wing assembly is now complete and ready to use. Set it aside for now.

MOTOR, RECEIVER, & ESC INSTALLATION:

The following parts are not included in your kit. These will be required for the following assembly steps:

- ❑ Motor of choice
- ❑ Mounting bolts & washers for your specific motor
- ❑ Prop adaptor for your specific motor shaft
- ❑ Electronic speed control (ESC)
- ❑ Receiver
- ❑ 3" or 4" of Velcro® for mounting the receiver & ESC

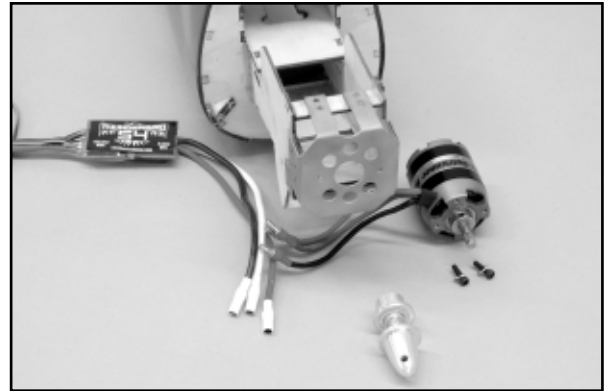

Note: The metal motor mount in the Bf-109 has been designed to accommodate the front mounting of most 35 mm diameter motors. The small holes give a general location for the tapped holes in the front of your motor. Enlarge or slot them as needed to accommodate your specific motor. We have used Himax HC3516-1130 and HC3522-0990 motors with the proper speed controls, props, and 3S1P LiPo 3300 mAh batteries in the prototypes and have been very satisfied with the performance and duration of these setups. We will show the HC3522-0990 in this manual as a typical motor installation.

- ❑ 1) Feed the motor wires through one of the openings next to the front motor mount plate and position the motor up to the back side of the front mounting plate. Bolt the motor to the mounting plate using the appropriate bolts and washers for your specific motor. We always suggest using a non-permanent thread-locking compound for these bolts, such as Loctite® "Blue". This simple precaution works very well to keep these bolts in place under vibration.

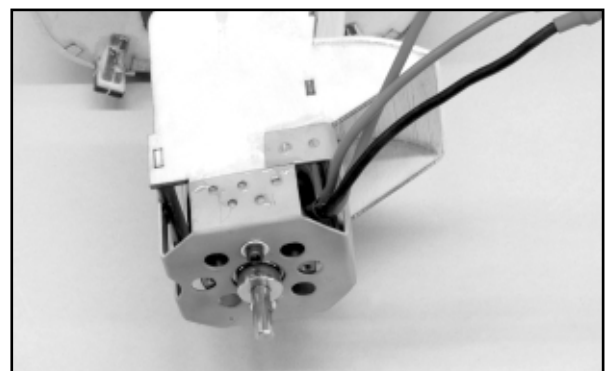

□ 2) Working through the fuselage wing saddle opening, feed the motor wires from your ESC forward into the nose, under the battery tray, until they exit below the motor. Plug the motor wires into the corresponding wires from ESC and then, slide the excess wiring back under the battery tray. Make sure to arrange these wires so that they do not contact the motor.

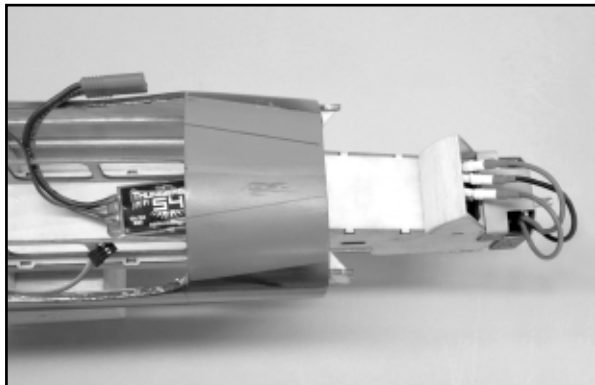

□ 3) The ESC is now secured to the bottom of the battery tray, ahead of wing. We suggest using Velcro® for this purpose. With the ESC now in place, feed the ESC battery connector wire along the side of the battery tray, up to the top of the tray.

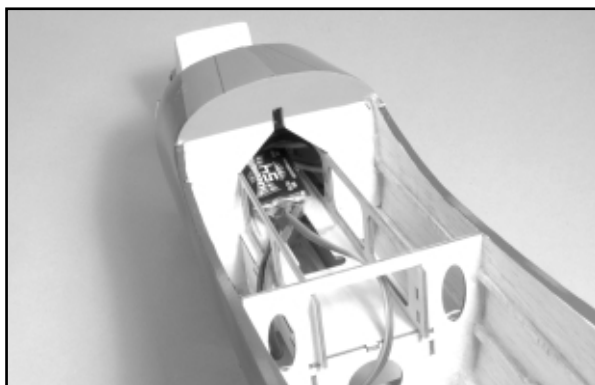

□ 4) The receiver is now installed into the fuselage on the bottom rear surface of the battery tray. Again, we suggest using a length of Velcro® for this purpose. Insert the ESC receiver lead into its appropriate throttle receptacle in the receiver. Using your transmitter and flight battery, connect the battery to the ESC battery connector and test the motor throttle function. Also, make sure the motor is turning in the correct direction. Disconnect the flight battery and turn off the transmitter.

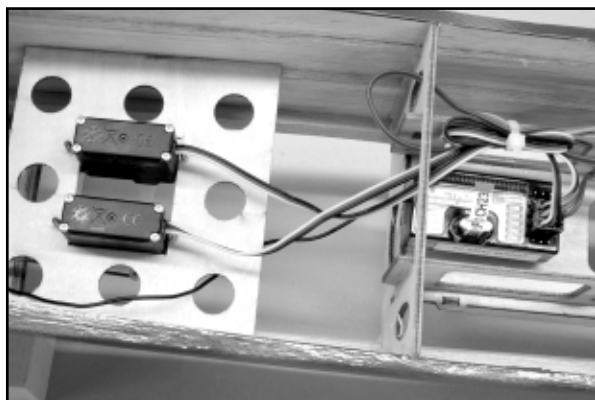

RUDDER & ELEVATOR SERVO INSTALLATION:

As mentioned earlier, the rudder and elevator servos do not need to be the sub-micro type used for the aileron servos. We used Hitec HS-81 servos in our Bf-109 prototypes to take advantage of their higher torque.

In the following steps you will need the following parts:

- 2 ea. 1.25 mm dia. x 597 mm wire pushrods
- 2 ea. Rudder & elevator servos (not included)

□ 1) From the kit contents, locate the two 1.25 mm dia. x 597 mm wire pushrods. Note that these pushrods are supplied with a "Z" bend at one end - this is the end that will attach to the servo output arm. From the canopy/hatch opening in the fuselage, insert the straight ends of the pushrods all the way into the two guide tubes behind the servo tray. Straighten these pushrods as needed to get smooth and easy travel.

Note: The pushrod guide tubes cross within the fuselage so that the pushrod for the elevator exits the left side of the fuselage while the servo is on the right side of the servo tray and the rudder is just the opposite.

□ 2) Prepare the two servos for installation by first inserting the rubber grommets and eyelets - supplied with the servos - into the mounting lugs at each end. Remove the servo arm retaining screw from each servo and then the servo arms.

□ 3) Place the servos into the top of the servo tray. Slide the servo to the outside of the servo tray opening and hold it there. Use a pencil to mark the servo mounting hole locations onto the servo tray. Repeat this process with the remaining servo. Remove the servos from the tray and use a 1/16" dia. (1.5 mm) bit to drill pilot holes at the mounting marks just made. Reinstall the servos and secure them to the tray using the mounting screws that came with them. Note that the output ends of these two servos are towards the front of the fuselage.

□ 4) With the servos now mounted, check the relationship between the two servo output arms when they are in place on the servos. If there is any interference, then you will have to select or modify servo arms that will not contact or interfere with each other during the operation of the servos. Remove the servo arms, then fit the "Z" bend ends of the pushrods onto the selected servo output arms and place the arms back onto the servos with the connected drive arms at 90° to the servo body as shown.

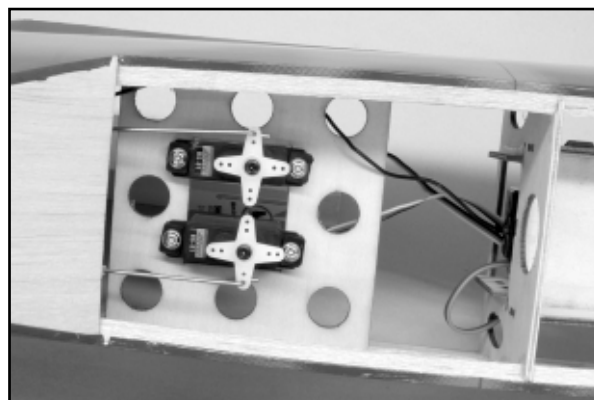

The servos are now tested using the radio system. Connect the appropriate rudder and elevator servo leads into the receiver, turn on the transmitter, and connect the flight battery to the ESC lead. Make sure the rudder and elevator trims are at neutral. Test the servos with the transmitter for proper movement and the alignment of the servo arms at neutral. If necessary, reposition the output arms to align them at 90° to the servo body at neutral. With arms now positioned correctly, reinstall the servo output arm retaining screws. Unplug the flight battery and turn off the transmitter.

MOUNTING THE COWL:

In the following steps you will need the following parts:

- ❑ Fuselage with motor mounted
- ❑ Prop adaptor part for your specific motor
- ❑ Flight propeller.
- ❑ Bag #6 Sub bag containing four (4) T2 x 12 mm PWA cowl mounting screws
- ❑ Bag #13 1 ea. Plywood spinner back plate



❑ 1) Mount prop adaptor on the motor output shaft and secure it in place. The provided plywood spinner backplate has a center hole diameter of 6 mm (just under 1/4"). This hole will likely have to be opened up to fit onto your propeller adaptor. Do this now. After establishing a good concentric fit, remove the plywood backplate from the adaptor. Tack glue four (4) 1/16" (1.5 mm) thick spacers to the back surface of the backplate, as shown. These will properly locate the cowl in relationship to the spinner. These spacers will be removed shortly.

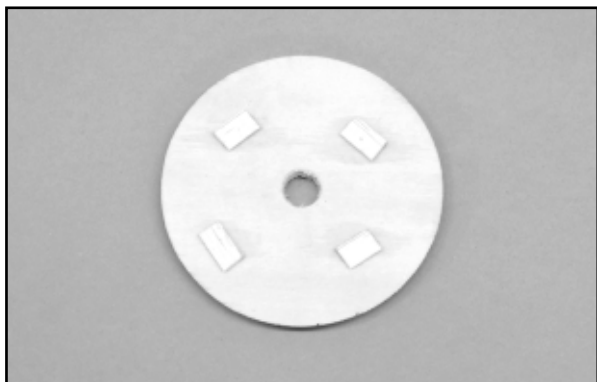

❑ 2) Slide the cowl in place onto the front of the fuselage, moving it back until the front of the cowl is slightly behind the face of the prop adaptor. Slip the spinner backplate onto the prop adaptor shaft with the 1/16" spacers towards the cowl. Place the propeller in position onto the prop adaptor shaft and tighten it in place with a propeller nut. This set-up should now have the

spinner backplate in its running position, allowing the cowl to be accurately mounted to the fuselage.



❑ 3) Position the front of the cowl to contact the spacers on the back of the spinner backplate and then, center the cowl to the backplate in both top and side views. Use tape to hold the cowl to the backplate in this centered position. Use a few more pieces of tape to hold the cowl to the fuselage at its back edges. The cowl should now be firmly and accurately in position. Using a #60 (.040" dia.) bit, drill four pilot holes through the plywood pads beneath the four pre-drilled holes in the cowl.



❑ 4) With a screwdriver, install the four cowl mounting screws through the holes in the cowl and into the plywood pads. Tighten the screws just enough to place the washer head in contact with the cowl - no more. Remove the pieces of tape, the propeller nut, the propeller, and the plywood backplate. Remove the 1/16" spacers from the rear of the backplate and lightly sand the backplate smooth.

MOUNTING THE TAIL SURFACES:

In the following steps you will need the following parts:

- ❑ Bag #1 Vertical fin and rudder assembly
- ❑ Bag #2 Horizontal stabilizer and elevator assembly
- ❑ Bag #12 2 ea. M4 x 30 mm Nylon wing bolts

❑ 1) Remove the elevators, rudder, and hinges from the tail surfaces. Insert the vertical fin into its slot at the top rear of the fuselage. It should bottom out on the built in platform at the bottom of the slot. The trailing edge of the fin should be in perfect alignment with the vertical tailpost of the fuselage - slide it forward or back until it is aligned. Next, use a sharp, soft pencil to mark both sides of the fin where it meets the fuselage at the slot. Remove the fin from the fuselage and use a sharp #11 blade to

carefully cut the covering about 1/32" below the line just drawn. Remove the covering, exposing the wood.

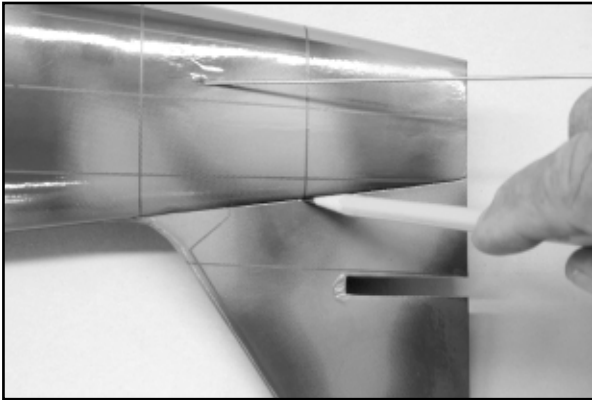

□ 2) Insert the stabilizer into the slot in the vertical fin until the trailing edge of the stabilizer is about 1/16" forward of the trailing edge of the fin. Again, use a sharp, soft pencil to mark the top and bottom stabilizer intersection lines onto each side of the vertical fin and the top and bottom of the stabilizer, where it intersects the rudder. Remove the stabilizer. Use a sharp #11 blade to carefully remove the covering from each side of the fin and stabilizer, between the two lines - make these cut lines about 1/32" inside of the drawn lines and use only enough pressure to cut through the covering, not the wood. Remove the covering to expose the wood beneath.

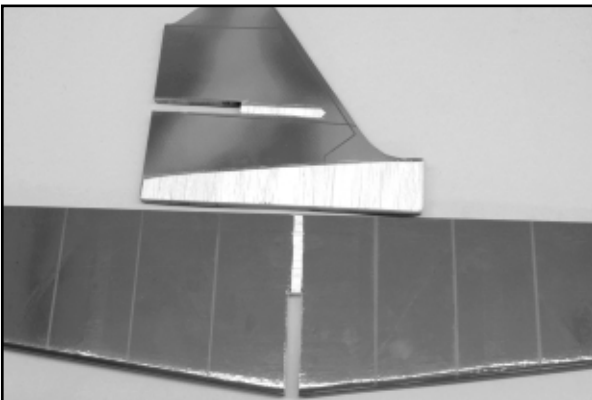

□ 3) The vertical fin and horizontal stabilizer are now glued together, accurately squared to one another, as shown. We highly

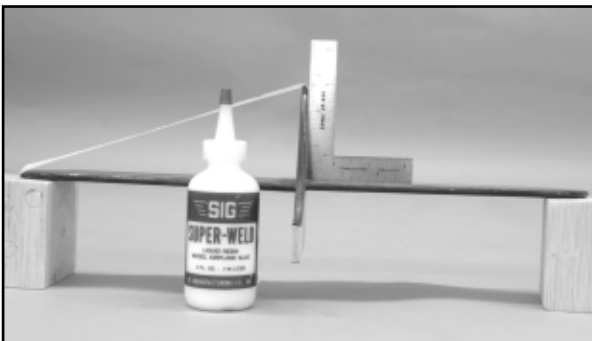

recommend the use of SIG *Super-Weld* white glue for this step because it allows a little working time, dries clear, and provides a very strong bond. If needed, a strip of tape works well to hold these parts in the properly squared position.

□ 4) The two elevator halves are now joined. We suggest using 15-minute epoxy for this step. Apply glue to the two joiner slots at

the inboard leading edge ends of each stabilizer half. Use a small diameter piece of wire or a pin to also apply glue into the joiner holes in each elevator half. Press the wire elevator joiner in place into each elevator half and quickly remove any excess glue. Place the elevator assembly on a flat work surface, protected with wax paper. Use a straightedge to align the elevator leading edges with each other, as shown. Allow the glue to fully cure before handling.

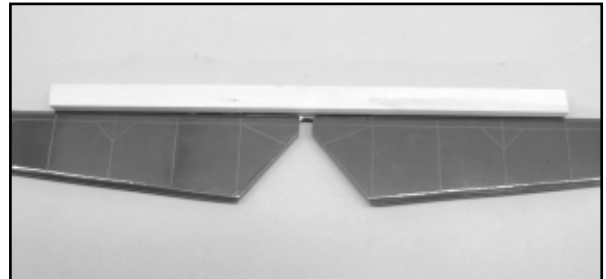

□ 5) In preparation for accurately gluing the tail group to the fuselage, first mount the wing to the fuselage using the two M4 x 30 mm nylon wing bolts.

Without using any glue, slip the fin/stabilizer assembly into the fin slot at the top rear of the fuselage. With the airplane on a flat surface and with the tail raised to approximately level, stand back and sight the model from the rear. What you want to see is the horizontal stabilizer perfectly level with the wings and the vertical fin sitting at 90° upright. If the stabilizer tilts one way or the other, lightly sand the bare wood on the bottom of the fin on the side that is low, until the stabilizer aligns properly. Once satisfied with the fit and alignment, remove the fin/stabilizer assembly from the fuselage.

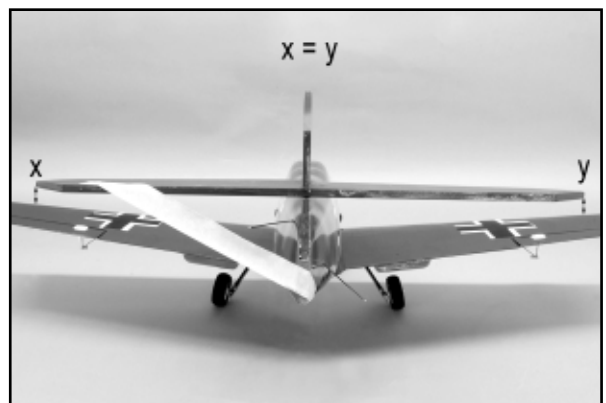

□ 6) Lightly coat the bare wood gluing surfaces on both sides of the fin with SIG *Super-Weld* white glue. Then, lightly coat both sides of the fin slot in the fuselage, again with white glue. Carefully slide the fin into the fuselage slot and wipe off any excess glue with a wet paper towel. As before, check, and then, double check the alignment. The trailing edge of the fin is in alignment with the fuselage tail post, the horizontal stabilizer is perfectly level with the wings and the vertical fin is sitting at 90°. If needed, a strip of masking tape can be used to hold proper alignment while the glue dries.

Once the glue has dried, remove the wing from the fuselage.

HINGING THE CONTROL SURFACES:

The following steps will require the following parts:

- Rudder & elevator with CA hinges - 6 hinges total
- Bag #8 - Tail Wheel assembly
- Bag #10 - 2 ea. Control horns
 - 2 ea. Control horn backing plates
 - 2 ea. Pushrod connectors
 - 2 ea. Connector keepers
 - 4 ea. M2 x 20 mm bolts

□ 1) The steerable tail wheel assembly is now installed into the bottom leading edge of the rudder. Note that this assembly is also the bottom hinge for the rudder. Because of this, a little extra clearance must be made to accept the brass tail wheel bearing. The rudder has been factory slotted for the brass hinge. The leading edge of this slot should be opened up a little more to accept at least one half of the bearing. We did this with a scrap piece of wire that was about the diameter of the bearing. Simply press this wire firmly into the slot area, forcing it to open a bit more. Trial-fit the tail wheel assembly in place to check the bearing fit. Once the bearing fits freely, the tail wheel assembly/hinge can be glued in place to the rudder. We suggest first coating the bearing area only with some Vaseline® to protect it from accepting glue and locking up. Use 15-minute epoxy to glue the tail wheel assembly and hinge into the bottom of the rudder. Carefully remove any excess glue and allow the glue to fully cure.

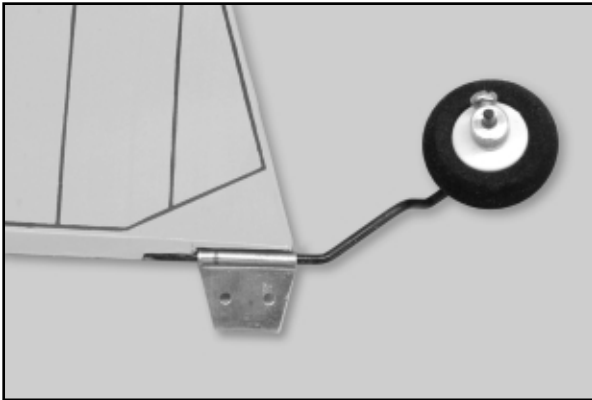

□ 2) The elevator control horn is now installed onto the bottom of the left elevator half. As shown, the center of the control horn is located 1-3/16" outboard of the inner elevator trim line. In top view, locate the control horn at this position, with its four vertical R/C link holes in line with the leading edge. Hold the control horn in this position and mark its two mounting holes onto the surface of the elevator. Use a #46 (.081" dia.) bit to drill two holes through the elevator at the marks just made. Use two M2 x 20 mm bolts and

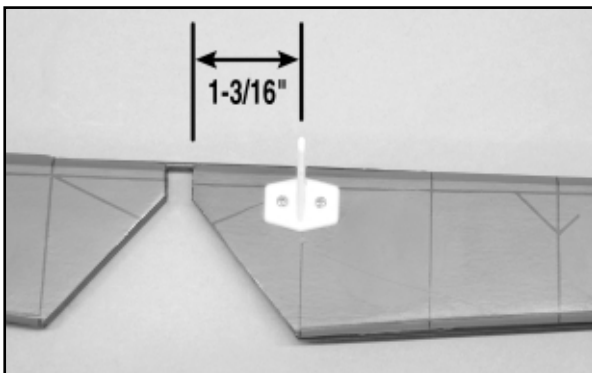

the plastic control horn backplate to secure the control horn in place. Cut-off the excess bolt ends and file smooth.

□ 3) The rudder control horn is now installed onto the bottom right side of the rudder. As shown, the control horn is positioned 1-1/8" up from the bottom leading edge of the rudder, with the four R/C link holes in line with the leading edge of the rudder. Hold the horn in this position and use a pencil to mark the two mounting hole locations onto the rudder. Again, use a #46 bit to drill two mounting holes through the rudder at the marks just made. Use the two remaining M2 x 20 mm bolts and the plastic control horn backplate to secure the horn in place. Cut off the excess bolt ends and file smooth.

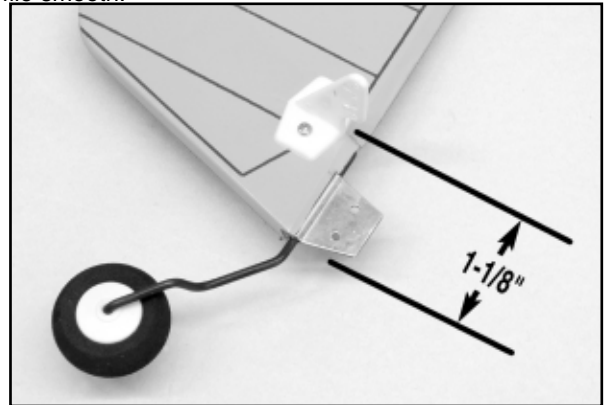

□ 4) The elevators are now hinged to the horizontal stabilizer. The hinging method is the same as described earlier for the ailerons. Use card wedges to center the hinges and remember to use a fine-tip applicator on your thin CA bottle to keep from getting any excess glue on the covering.

□ 5) The rudder can now be hinged in place to the vertical fin and fuselage. Note that the bottom hinge slot entry location in the tailpost of the fuselage should be opened a little more to accept the tail wheel bearing diameter. As we did with the rudder, use a short length of scrap wire to lightly force this area open, to accept about one half of the bearing diameter when the rudder is fully in place. We also found that the bottom hinge slot needs to be opened up a little more to accept the thickness of the brass hinge. This can be easily done with a #11 blade or even a #27 X-acto saw blade.

Using the two remaining CA hinges, trial fit the rudder fully in place, making sure it has free movement. Make any adjustments necessary to achieve this. Once satisfied with the fit and movement, remove the rudder, leaving the CA hinges in the vertical fin. Carefully apply a thin coat of Vaseline® to the tail wheel bearing area to protect it from excess glue. The brass tail wheel hinge is glued in place using 15-minute epoxy. First, place two of the card wedges into the center CA hinge slots. Next, lightly coat both sides of the brass hinge half with epoxy glue. Use a piece of business card to now work some epoxy glue into the fuselage hinge slot, cleaning up any excess. Now, insert the brass hinge half partially into its slot in the fuselage and engage the two CA hinges into their slots in the rudder. Press the rudder in place to the fuselage and fin.

The two rudder CA hinges can now be glued in place using the same method described earlier during the hinging of the ailerons. Allow time for the CA glue to fully wick across the surface of the

hinges and surrounding wood. Once sufficient time has passed, move the rudder briskly left and right to free up its movement.

□ 6) The pushrod connections are now made between the elevators and rudder and their corresponding servos. Starting with the elevator pushrod, slide a pushrod connector onto the elevator pushrod wire. Now, install the pushrod connector stub into the last outer hole in the elevator control horn and secure it to the horn with the metal cup washer. Repeat this procedure for the rudder pushrod, installing the pushrod connector stub into the second inboard hole in the rudder control horn, as shown.

Turn on your transmitter and power up the receiver with your flight battery pack. Once again, check the rudder and elevator trims, making sure they are at neutral settings. Hold the elevators in the neutral position to the horizontal stabilizer, using a couple of small pieces of tape applied to the outboard hinge lines. With the elevators now locked in neutral, use a screwdriver to firmly tighten the setscrew in the elevator pushrod connector. Remove the tape holding the elevators. Moving to the rudder, again use a piece of tape to hold the rudder in neutral to the vertical fin. With the rudder now locked in this position, use a screwdriver to firmly tighten the setscrew in the rudder pushrod connector. Remove the tape holding the rudder.

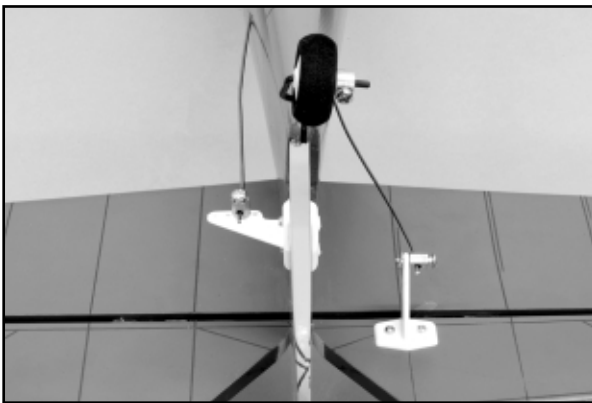

Use the transmitter to now test the movement of both the elevators and rudder. If the movement of either of these surfaces in the wrong direction, use the servo reversing function to change the movement and, if necessary, re-center the surfaces to achieve a neutral setting.

□ 7) The excess pushrod wire behind the pushrod connectors can now be cut off, leaving about 3/16" of wire for any later final flight trimming purposes.

INSTALLING THE TAIL BRACES:

For these steps you will need the following parts:

- Bag #16 2 ea. 2 mm x 94 mm wire tail braces - M2 threads at one end, bent "eye" at the other end - 1 left, 1 right
- 2 ea. Tail brace mounting tabs - pre-bent and drilled
- 2 ea. R/C Links with silicone keepers
- 2 ea. Knurled lock nuts
- 2 ea. T2 x 6 mm PWA screws
- 2 ea. T2 x 8 mm PWA screws



□ 1) Mark the location of the metal mounting tabs on the bottom of the stabilizer. Measure 3-3/16" (81 mm) from the side of the fin on each side. This should be about the center of the hardwood rib in the stabilizer. From the elevator hinge line, measure 1-1/2" (38 mm) forward. The intersection of these two marks is the mounting location for the metal mounting tab. Use a sharpened awl to puncture the covering and a little of the hardwood rib. Use two T2 x 6 mm PWA screws to mount the two metal tabs to the bottom of the stabilizer, as shown.

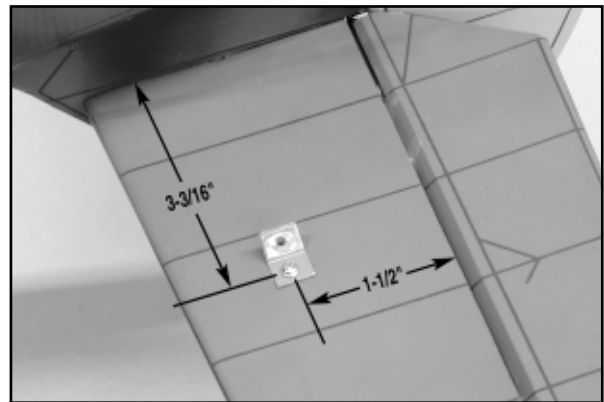

□ 2) Adjust the two braces for length. They should both be 4" (101 mm) long, measured from the pin of the R/C link to the center of the bent eye at the opposite end. Lock this setting with the knurled lock nut.

□ 3) On the bottom rear of the fuselage, measure 2-1/4" (56 mm) forward from the rudder hinge line and make a mark on each side. This is where the eye of the brace will be mounted to the fuselage. Clip the R/C link to the tab on the stabilizer and position the eye of the brace wire even with the 2-1/4" mark. Use a sharpened awl to puncture the covering and wood at the center of the eye. Use two T2 x 8 mm PWA screws to mount the braces to the bottom of the fuselage. Remove the screws and swing the braces out of the way.

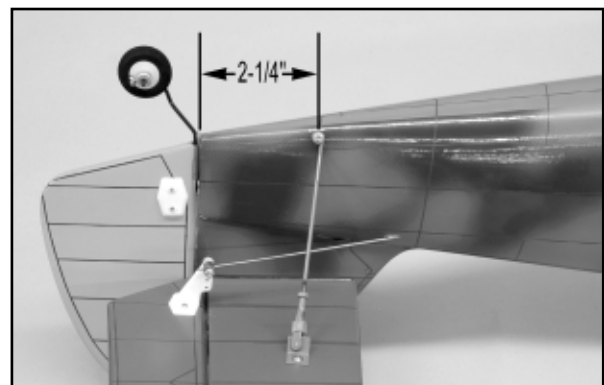

Use a fine applicator tip and thin CA to place a drop of glue into the screw holes in the fuselage to "harden" them. Reinstall the braces and screws.

FINAL DETAILS:

The canopy is now mounted in place over the cockpit. From the kit parts, locate the canopy and the four T2 x 6 mm PWA mounting screws. In top view, the canopy is centered over the cockpit with approximately 1/8" of its rear edge extending back past the rear surface of the slanted cockpit/fuselage former. Use small pieces of tape to hold the canopy in this position. Use the four T-2 x 6 mm PWA screws; threaded through the provided holes in the canopy, to secure the canopy in this final mounted position. Remove the tape holding the canopy, and then, remove the four mounting screws. We suggest using a fine tip applicator with thin CA to harden each of the screw holes. A single small drop of thin CA glue, applied directly into each hole will provide hardened threads for secure mounting.



The simulated supercharger air scoop (Bag #11), located on the left side of the cowl is now glued in place with the lower front corner of the scoop 1-1/2" (38 mm) ahead of the back edge of the cowl and 3/8" (9.5 mm) above the exhaust manifold. To mount this part, we used thick CA glue, sparingly applied to the bottom surface of the air scoop.

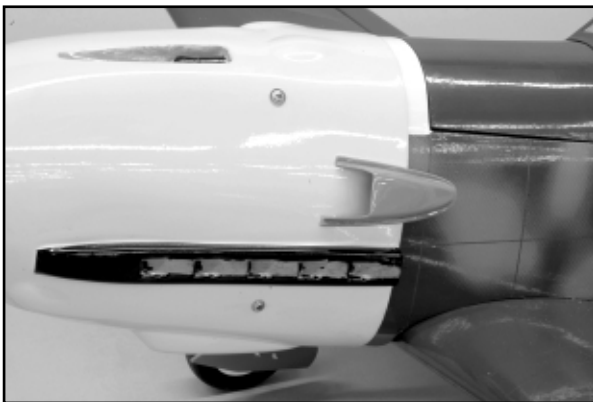

If desired, typical plastic paints can be used to add a little more detail and realism to the cowl. The two machine gun troughs on top of the cowl can be painted flat gray to simulate gunpowder staining. The molded gun barrels can be painted flat black. The two exhaust manifolds can be painted a smoky gray to simulate burning exhaust.



If desired, a functional, scale-like antenna mast can be made using a 3" (75 mm) length of scrap nylon pushrod tubing, pre-painted either in gray or flat black. Drill a pilot hole for this antenna mast, 1/2" behind the top rear edge of the canopy, centered on the top of the fuselage. The antenna mast is now glued into the drilled hole using 5-minute epoxy glue. The receiver antenna can now be routed up through the antenna mast tube and extended back to the top leading edge of the vertical fin where it can be secured with a small bead-head pin.



Many of us enjoy seeing a pilot figure in the cockpit of our models. In the case of the Bf-109, this simple addition looks great and provides a sense of scale and realism to the finished airplane. Our pilot figure started life as a Williams Bros. 1/6th scale Standard Pilot figure. After assembling it, we, then, cut down the figure to fit within the cockpit area. Then, we used plastic paints to add color and finish to the pilot. We mounted him in place and remounted the canopy.



PREPARING THE SPINNER:

The plastic spinner cone supplied with this kit has a unique shape, peculiar to the Bf-109 and is supplied uncut. This is to allow the builder to use it for a 2 or 3 bladed prop for either flying or display. Finishing this spinner is not difficult but does require some care.

Note that mounting this spinner requires an adapter nut that threads onto the shaft of your particular motor at one end and is tapped for an 8-32 bolt on the opposite end. C.B. Associates makes these adapter nuts in any size that you will need. You will also need an 8-32 x 3/4" socket head bolt and a several #8 washers for use as spacers.

For the following steps, locate Bag #13 containing the spinner parts.

- ❑ 1) To locate the cutout locations for the blades of a two bladed propeller, start by drawing a straight line across the back surface of the plywood spinner backplate, exactly through the center of the prop shaft hole. On a flat surface, place and hold the spinner over the backplate and use a pencil to transfer the two opposing edge marks onto the back edge of the spinner cone.

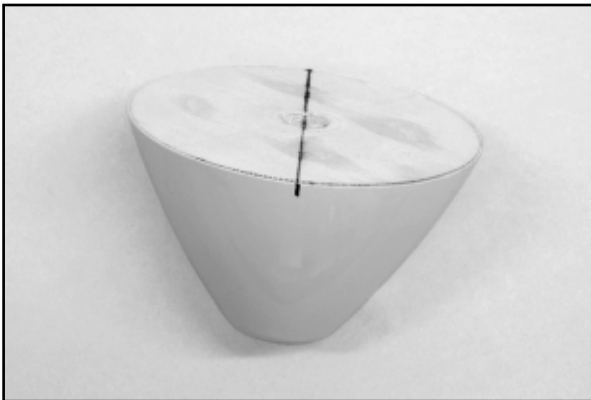

Note: If you want to use a three-bladed propeller, use a compass to make three pencil marks at 120° apart.

- ❑ 2) Cut out the propeller template found on page 16. Align the leading edge of the template with one of the marks on the edge of the cone. Tape the template in position and trace the outline of the blade cutout onto the cone. Move the template over to the opposite mark, tape it in place and use pencil to trace the remaining blade cutout outline. The prop blade cutouts are now made in the spinner. To make this relatively easy and accurate, we used a Dremel® Tool with a highly tapered sanding bit, followed by sandpaper to smooth the edges.



- ❑ 3) Use thick CA glue or 5-minute epoxy to glue the two 20 mm dia. plywood washers together with their center holes aligned. Glue the laminated 20 mm washer assembly to the inside flat nose of the plastic spinner, aligning the center hole with the molded "dimple" on the inside of the spinner. Use thick CA glue or 5-minute epoxy. After the glue sets, use a #19 (.166 dia.) bit to drill through the front center of the spinner, at the dimple mark.

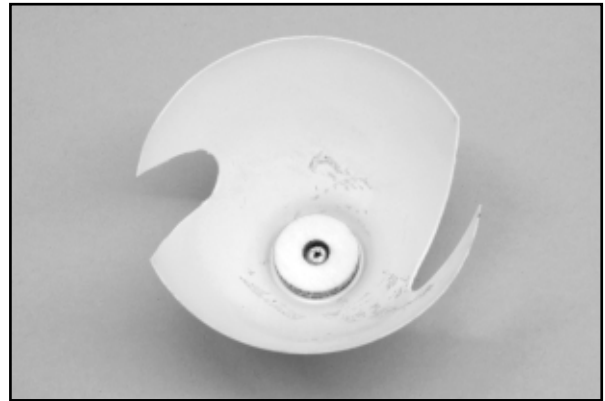

- ❑ 4) Place the spinner backplate on the motor shaft and then, the propeller. Tighten these parts in place with the adaptor nut.



Insert an 8-32 x 3/4" bolt into the front of the cone and place about 4 washers on the bolt on the inside of the spinner. Thread the bolt into the adapter nut and adjust the number of washers on the bolt until the skirt of the cone is just even with the bottom of the plywood backplate when the bolt is tightened down. This spacing will remain the same as long as you replace the prop with an identical prop. Changing brands and/or sizes of props will more than likely change the required amount of shims.



Modeler's Note: A standard 2-3/4" dia. yellow nylon spinner, such as a SIG # SIGSP2755, can be used to make a nice looking alternative spinner, by simply cutting off 1/2" from the tip of the spinner cone.

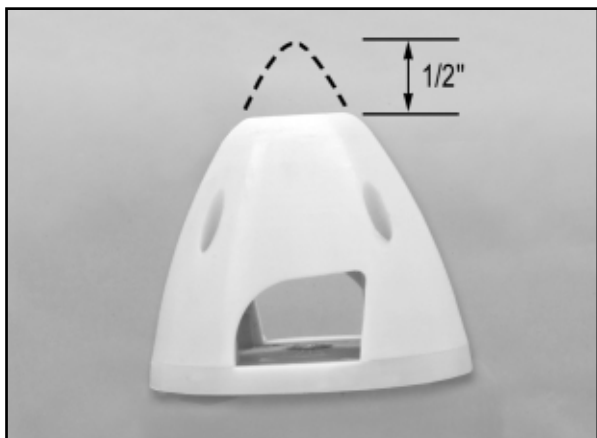

Once this cut has been made, the cut line should be rounded off, giving the appearance of the scale opening for the cannon muzzle. To do this, we used a bolt and a nut as an arbor and then, installed the end of the bolt in a drill press. With the spinner turning, sandpaper was used to uniformly and neatly round off the opening.



The finished spinner should look like the photo.



CENTER OF GRAVITY:

Establishing the Center of Gravity (C.G.) for this or any R/C model aircraft is critical to its ultimate success in the air. And determining the proper C.G. location becomes even more important with

smaller models. While the Bf-109 is a solid, predictable airplane to fly, it is, none-the-less, a warbird type aircraft and is less tolerant to improper C.G. locations than other model types.

Start by installing the battery pack that you will be using to power the airplane. Slide the pack as far forward in the battery tray as possible and secure it in this position to keep it from shifting while you are working with the model. Attach the cockpit/hatch over the battery compartment.

The correct C.G. location for this model is exactly 2-1/2" (63.5 mm) behind the leading edge, at the fuselage/wing location. Use two pieces of masking tape, applied onto each side of the top surface of the wing, where it meets the fuselage wing saddle. Bolt the wing in place to the fuselage and use a ruler to measure and mark the 2-1/2" location onto the tape, immediately next to the fuselage.

With the airplane now assembled with the battery pack in place, it is ready for balancing. The best way to do this is to place the model onto a balancing fixture upside down. Locate the balancing fixture at the two 2-1/2" marks on each side of the wing, next to the fuselage sides. If the model is properly balanced, it will be suspended perfectly level. If the nose hangs down, the airplane is nose heavy and conversely, if the tail hangs down, the model is tail heavy. A slightly nose heavy model is certainly the lesser of two evils. However, a tail heavy condition must be remedied before flying the airplane.

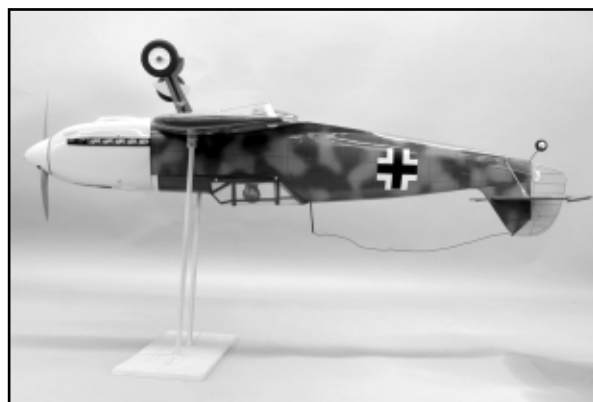

If your model balances a little nose heavy, the battery pack can be shifted a little aft to correct the problem. If the model balances in a tail heavy condition, then, it is likely necessary to modify the existing battery tray, allowing the flight battery to be shifted even further forward. As shown with our Himax 400 watt motor installation, we were able to modify the battery tray, allowing the battery pack to slide a full 1-1/4" further forward.

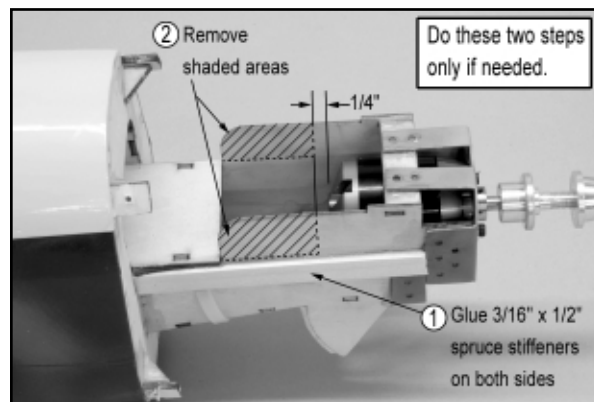

Again, as shown, the battery pack, in place in the battery tray, now sits directly behind the motor with a piece of scrap 1/4" balsa in place to keep it from shifting. This "fix" works well when using lighter motors and is far superior to adding weight to achieve proper balance.

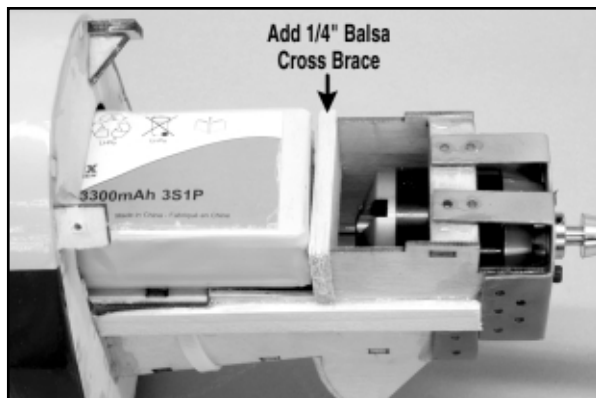

Once you have achieved the proper 2-1/2" C.G. location by shifting the battery as needed, mark and note the battery location onto the battery tray to ensure that it is installed and retained in the proper position, every time the model is flown.

CONTROL MOVEMENTS:

The Bf-109 is a fighter plane and as such, is designed to be responsive to your control inputs. It is very important to set your model up to these recommended throws, for the first flight, to avoid any nasty surprises, especially on elevator. Set the throws as close to these specifications as possible mechanically by moving the linkages in or out on the servo arms and control horns, then fine tune these throws with the adjustments available in the transmitter.

Recommended Initial Control Movements:

- ELEVATORS:** 1/2" (12 mm) up and down
- AILERONS:** 3/8" (9.5 mm) up and down
- RUDDER:** 7/8" (22.25 mm) left and right

FLYING:

If you have carefully followed this assembly manual, you should have no real problem test flying your Bf-109. We suggest choosing a calm day for the first flights. Such conditions always help in correctly evaluating the flight performance of the model.

If you have built your Bf-109 model without landing gear, the requirement is, of course, to hand-launch the airplane. The hand-launch can be done by a friend and, with a little experience, you can also learn to launch the model by yourself. To properly hand-launch a low-wing model like the Bf-109, the fuselage is firmly gripped just behind the wings. The airplane should be briskly launched straight ahead, directly into the wind, with the wings level and the motor at high throttle. The launch should be aimed directly at the horizon - never hand-launch the model with the nose up!

If you have built your Bf-109 model with the landing gear, then of course, the airplane can be taken off from the ground. Arm the motor and test the flight controls for correct movement. Hold up elevator and taxi the model to get a feel for how it handles on the ground. Make sure you have positive left and right turning ability.

If you don't, make any adjustments needed to achieve positive ground control. Once you are satisfied with the taxi tests, line the model up with the center of the runway with the nose pointed directly into the wind. Hold a little up elevator and smoothly advance the throttle - do not throw the throttle fully open all at once! The model should roll forward smoothly, tailwheel on the ground. As is typical of this type of airplane, you will need to be ready with some right rudder as you slowly release the up elevator and allow the tail to rise. Allow the speed to build until a slight application of up elevator breaks it free from the runway. Do not try to force it into the air before it is ready to fly.

Once the airplane is airborne, maintain a straight outward flight path, climbing at a shallow angle, until a safe maneuvering altitude is reached. If the model requires trim input, fly to a reasonable altitude before attempting to make any changes. Make your control inputs smooth and avoid jerking the sticks. At trimming altitude, bring the throttle back to about a 2/3rds setting for cruise speed and then, begin fine-tuning any required trims. What you want to achieve is a straight and level flight path without transmitter corrections.

Once you're comfortable with the way the model is flying, make a few circuits around the field, getting a feel for the controls. If the airplane is properly trimmed, it should demonstrate smooth flight characteristics, without any jumpiness or over sensitivity. At altitude, try an axial roll. Next, try another roll in the opposite direction. The Bf-109 should roll smoothly in each direction. Next, try a simple inside loop. Choose your entry heading and go to full throttle. Pull up smoothly until the airplane is inverted, then back off the throttle as it comes down the backside of the loop. Consecutive loops are easily done using the same technique. This maintains a steady airspeed and conserves battery power. Still at cruise speed and reasonable altitude, roll the model inverted. A properly balanced model will take very little down elevator to maintain inverted flight.

By now, you should be getting comfortable with the handling of your Bf-109. Fly the airplane up to a safe altitude, flying directly into the prevailing wind. Throttle back the motor to become familiar with the slow flight characteristics of the model. Still at a lower throttle setting, make a few dummy landing approaches,

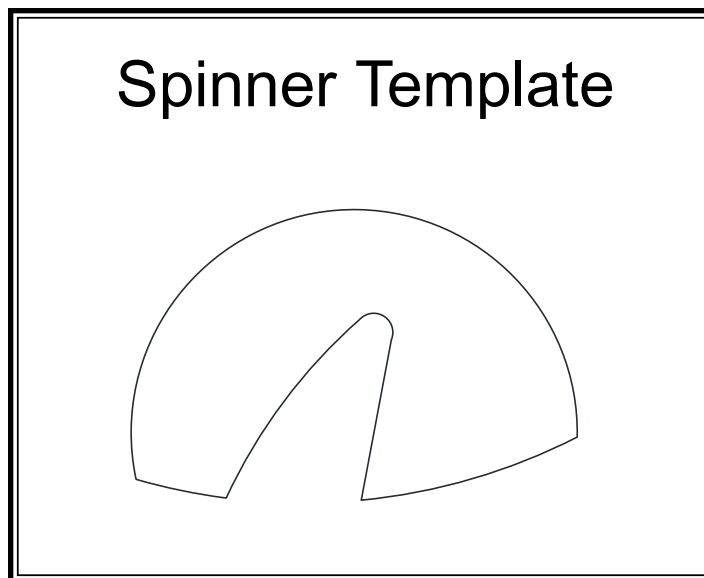

including the required turns. What you're looking for is a comfortable landing speed. Now, try a few power-on and power-off stalls. Again, you're looking for the speed at which the model stalls and also for the type of stall that will occur. All of this is great information to have when you are setting up your first landing.

After making a few high-speed strafing passes over your field, it's likely time to set-up your Bf-109 for a landing.

We always suggest that you make your landings using a standard approach. Enter the downwind leg at about 50' in the air, throttled back just enough to allow the airplane to very gradually sink. Make the base turn, followed by the final turn, lined up with the center of the runway. Keep a little power on the model, while keeping the nose just slightly down. Fly to the touch down location until the model is a foot or so off the ground. Start easing off of the throttle, allowing the airplane to touch down on the main wheels. Allow the tail wheel to settle to the ground and let the model finish its rollout to a stop. Hold full up elevator and taxi back to the pits. With some experience, you'll be making very nice landings every time.

With the first flight now in your logbook, it is time to completely check everything in and on the model that may have come loose or needs attention. In our long experience with model aircraft, we've learned that anything that might come loose or needs attention, will show up within the first few flights. Do yourself a favor and check everything now. The second flight should be even more fun because you now have a trimmed model.

MAINTAINING YOUR Bf-109:

Getting into the habit of routinely performing maintenance and inspection of your Bf-109 will keep it looking good and flying good

for a long time. Full scale airplanes receive this kind of routine treatment and fly safely for years. Your R/C model aircraft should receive the same treatment.

After each flying session take the time to completely clean your model. If you are used to cleaning up glow powered models, you should really enjoy how easy it is to clean up an electric model! We use and suggest fresh, good quality paper towels and a silicone free cleaner for degreasing and polishing. SIG makes one of the best cleaners for this purpose - Pure Magic Airplane Cleaner. Clean the airplane until it shines including the prop and spinner.

At home take a little time to completely inspect the airplane, looking for loose bolts, screws, covering seams, etc. *Anything that you find wrong - **immediately fix it!*** Inspect the fuselage radio compartment carefully. Check each servo, looking for loose linkages, missing screws, etc. Check each R/C link for integrity and to make sure the keepers are in place. Check all the control horns and servo arms to be sure they are firmly attached to the control surfaces.

Finally, after each flying session you should monitor the charge on your radio system, charging it as needed. If several days pass before you fly again, top off the charge before flying again. Be sure that the radio is fully charged before heading out to the flying field again.

Good luck and good flying.....

Messerschmitt Bf-109 Log Book

Date of first flight:

Comments:

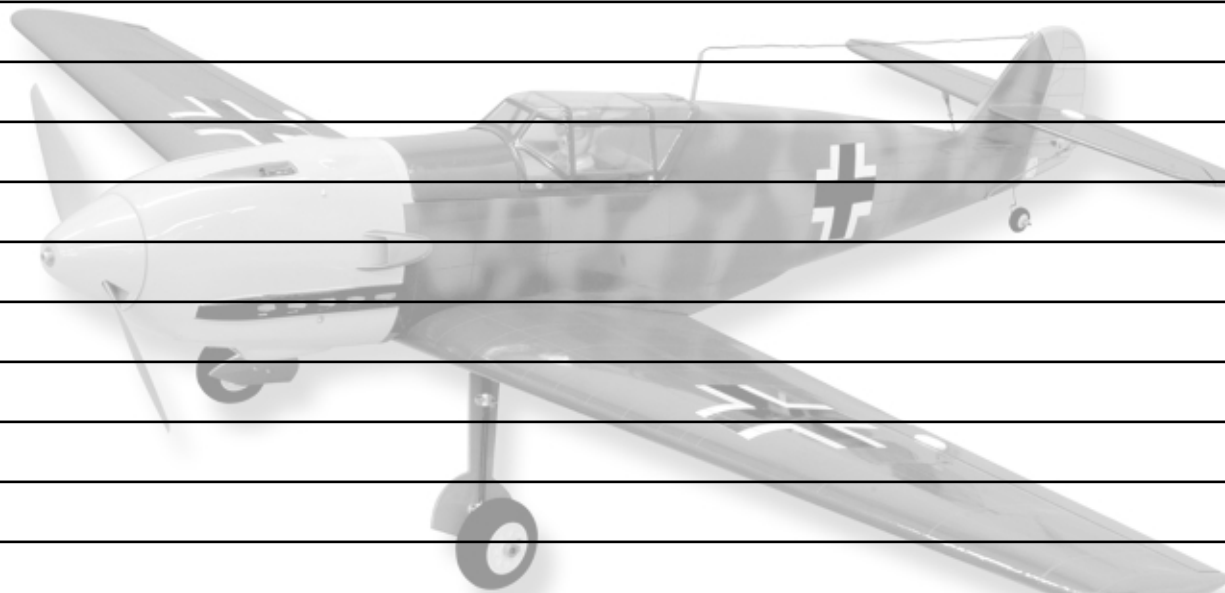

WARNING! THIS IS NOT A TOY!

Flying machines of any form, either model-size or full-size, are not toys! Because of the speeds that airplanes must achieve in order to fly, they are capable of causing serious bodily harm and property damage if they crash. **IT IS YOUR RESPONSIBILITY AND YOURS ALONE** to assemble this model airplane correctly according to the plans and instructions, to ground test the finished model before each flight to make sure it is completely airworthy, and to always fly your model in a safe location and in a safe manner. The first test flights should only be made by an experienced R/C flyer, familiar with high performance R/C aircraft.

The governing body for radio-control model airplanes in the United States is the **ACADEMY OF MODEL AERONAUTICS**, commonly called the **AMA**. The **AMA SAFETY CODE** provides guidelines for the safe operation of R/C model airplanes. While AMA membership is not necessarily mandatory, it is required by most R/C flying clubs in the U.S. and provides you with important liability insurance in case your R/C model should ever cause serious property damage or personal injury to someone else. For more information, contact:

ACADEMY OF MODEL AERONAUTICS
5161 East Memorial Drive
Muncie, IN 47302
Telephone: (765) 287-1256

AMA WEB SITE: modelaircraft.org

CUSTOMER SERVICE

SIG MANUFACTURING COMPANY, INC. is committed to your success in both assembling and flying the MESSERSCHMITT Bf-109 ARF kit. Should you encounter any problem building this kit, or discover any missing or damaged parts, please feel free to contact us by mail or telephone.

SIG MANUFACTURING COMPANY, INC.
P.O. Box 520
401-7 South Front Street
Montezuma, IA 50171-0520 USA

PHONE: 1-641-623-5154

FAX: 1-641-623-3922

SIG WEB SITE: www.sigmfg.com

SIG E-MAIL: mail@sigmfg.com

LIMIT OF LIABILITY

The craftsmanship, attention to detail and actions of the builder/flyer of this model airplane kit will ultimately determine the airworthiness, flight performance, and safety of the finished model. SIG MFG. CO.'s obligation shall be to replace those parts of the kit proven to be defective or missing. The user shall determine the suitability of the product for his or her intended use and shall assume all risk and liability in connection therewith.

**MORE GREAT PRODUCTS FROM
SIG MANUFACTURING COMPANY!**

KADET-EP-42B

Electric Powered Trainer!
w/Brushless Motor & Speed Control

Kadet EP-42B ARF
Kit No. SIGRC104ARFB - White w/Trans. Blue
SIGRC104ARFR - White w/Trans. Red



SimTransmitter

SimTransmitter (Throttle - Right) Mode 1
Order No. RCSRC39000B
SimTransmitter (Throttle - Left) Mode 2
Order No. RCSRC39000A

E-FORCE **ALMOST READY TO FLY**

E-Force ARF
Kit No. SIGRC75ARF

